

Instructions – Parts List



AIR POWERED, DIVORCED DESIGN

63:1 Ratio King™ Pump

307663W

5000 psi (345 bar) maximum fluid working pressure

79 psi (5.4 bar) maximum air input pressure

Model 218174, series E

With standard air motor and Severe-Duty* displacement pump

Model 220505, series C

With quiet air motor and Severe-Duty* displacement pump

Model 223601, series A

With quiet air motor and Severe-Duty* displacement pump
Stainless steel glands, intake housing, piston valve and ball stop

*Severe-Duty displacement pumps have an abrasion and corrosion-resistant displacement rod and sleeve. Refer to the Technical Data on page 23 for wetted part information.

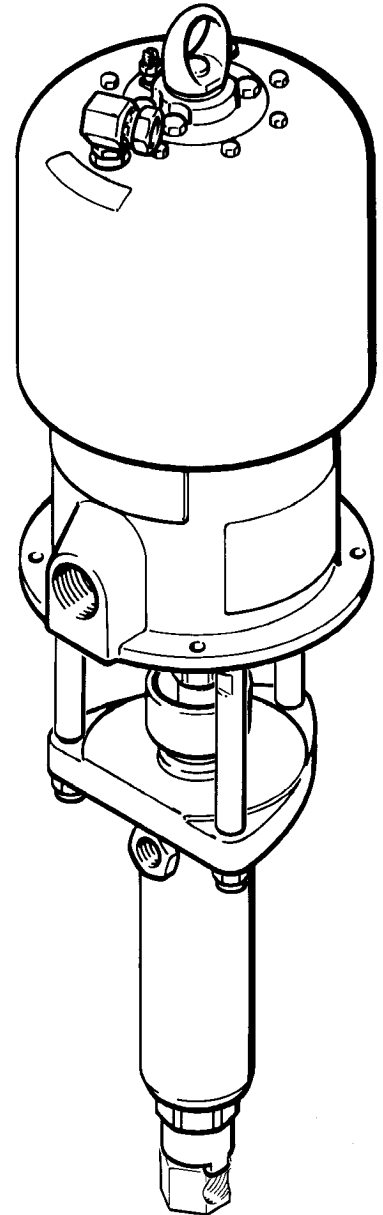

Model 218174 Shown

Table of Contents

Warnings and Symbols	2
Setup	5
Operation	8
Troubleshooting	10
Service	11
Parts	14
Accessories	20
Technical Data	23
Dimensions	22
Warranty	24
Graco Phone Number	24



Read warnings and instructions.

Symbols

Warning Symbol



This symbol alerts you to the possibility of serious injury or death if you do not follow the instructions.

Caution Symbol



This symbol alerts you to the possibility of damage to or destruction of equipment if you do not follow the instructions.

WARNING



INSTRUCTIONS

EQUIPMENT MISUSE HAZARD

Equipment misuse can cause the equipment to rupture or malfunction and result in serious injury.

- This equipment is for professional use only.
- Read all instruction manuals, tags, and labels before operating the equipment.
- Use the equipment only for its intended purpose. If you are uncertain about usage, call your Graco distributor.
- Do not alter or modify this equipment. Use only genuine Graco parts and accessories.
- Check equipment daily. Repair or replace worn or damaged parts immediately.
- Do not exceed the maximum working pressure stated on the equipment or in the **Technical Data** for your equipment. Do not exceed the maximum working pressure of the lowest rated component in your system.
- Use fluids and solvents which are compatible with the equipment wetted parts. Refer to the **Technical Data** section of all equipment manuals. Read the fluid and solvent manufacturer's warnings.
- Do not use hoses to pull equipment.
- Route hoses away from traffic areas, sharp edges, moving parts, and hot surfaces. Do not expose Graco hoses to temperatures above 180°F (82°C) or below -40°F (-40°C).
- Wear hearing protection when operating this equipment.
- Do not lift pressurized equipment.
- Do not lift the equipment by the air motor lift ring if the total weight of the equipment exceeds 550 lb (250 kg).
- Comply with all applicable local, state, and national fire, electrical, and safety regulations.

⚠ WARNING



INJECTION HAZARD

Spray from the gun, hose leaks, or ruptured components can inject fluid into your body and cause extremely serious injury, including the need for amputation. Fluid splashed in the eyes or on the skin can also cause serious injury.



- Fluid injected into the skin might look like just a cut, but it is a serious injury. **Get immediate medical attention.**
- Do not point the gun at anyone or at any part of the body.
- Do not put your hand or fingers over the spray tip.
- Do not stop or deflect leaks with your hand, body, glove or rag.
- Do not “blow back” fluid; this is not an air spray system.
- Always have the tip guard and the trigger guard on the gun when spraying.
- Check the gun diffuser operation weekly. Refer to the gun manual.
- Be sure the gun trigger safety operates before spraying.
- Lock the gun trigger safety when you stop spraying.
- Follow the **Pressure Relief Procedure** on page 8 whenever you: are instructed to relieve pressure; stop spraying; clean, check, or service the equipment; and install or clean the spray tip.
- Tighten all fluid connections before operating the equipment.
- Check the hoses, tubes, and couplings daily. Replace worn, damaged, or loose parts immediately. Permanently coupled hoses cannot be repaired; replace the entire hose.
- Use only Graco approved hoses. Do not remove any spring guard that is used to help protect the hose from rupture caused by kinks or bends near the couplings.



MOVING PARTS HAZARD

Moving parts, such as the pump rod, follower plate and ram assembly, can pinch or amputate your fingers.

- Keep clear of all moving parts when starting or operating the pump.
- Keep your hands away from the follower plate and the lip of the drum while the ram is operating.
- Keep your hands away from the ram frame while the ram is operating.
- Before servicing the equipment, follow the **Pressure Relief Procedure** on page 8 to prevent the equipment from starting unexpectedly.

WARNING



FIRE AND EXPLOSION HAZARD

Improper grounding, poor ventilation, open flames or sparks can cause a hazardous condition and result in a fire or explosion and serious injury.



- Ground the equipment and the container where the material is deposited. Refer to **Grounding** on page 7.
- If there is any static sparking or you feel an electric shock while using this equipment, **stop the pumps immediately**. Do not use the equipment until you identify and correct the problem.
- Provide fresh air ventilation to avoid the buildup of flammable fumes from solvents or the fluid being sprayed.
- Keep the spray area free of debris, including solvent, rags, and gasoline.
- Electrically disconnect all equipment in the spray area.
- Extinguish all open flames or pilot lights in the spray area.
- Do not smoke in the spray area.
- Do not turn on or off any light switch in the spray area while operating or if fumes are present.
- Do not operate a gasoline engine in the spray area.



TOXIC FLUID HAZARD

Hazardous fluid or toxic fumes can cause serious injury or death if splashed in the eyes or on the skin, inhaled, or swallowed.

- Know the specific hazards of the fluid you are using.
- Store hazardous fluid in an approved container. Dispose of hazardous fluid according to all local, state and national guidelines.
- Always wear protective eyewear, gloves, clothing and respirator as recommended by the fluid and solvent manufacturer.

Setup

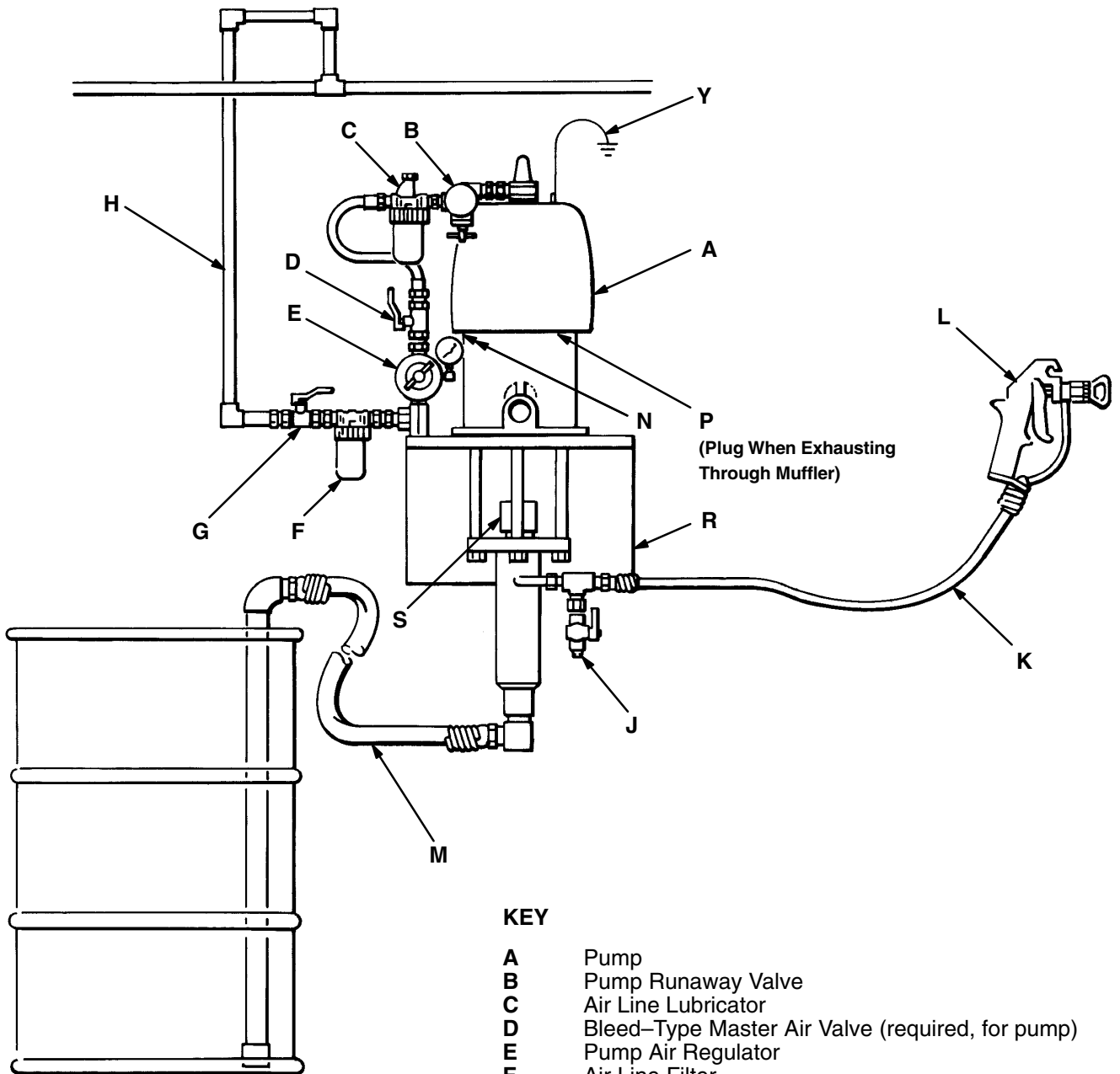

KEY

- A Pump
- B Pump Runaway Valve
- C Air Line Lubricator
- D Bleed-Type Master Air Valve (required, for pump)
- E Pump Air Regulator
- F Air Line Filter
- G Bleed-Type Master Air Valve (for accessories)
- H Air Supply Hose
- J Fluid Drain Valve (required)
- K Fluid Supply Hose
- L Spray Gun
- M Fluid Suction Hose
- N Exhaust Port for Muffler (1-1/4" npt)
- P 16 Exhaust Holes
- R Wall Bracket
- S Packing Nut/Wet-Cup
- Y Ground Wire (required)

Setup

NOTE: Reference numbers and letters in parentheses in the text refer to the callouts in the figures and the parts drawing.

See page 20 for accessories available from Graco. If you supply your own accessories, be sure they are adequately sized and pressure-rated to meet the system's requirements.

The Setup shown on page 5 is only a guide for selecting and installing system components and accessories. Contact your Graco representative or Graco Technical Assistance (see back page) for assistance in designing a system to suit your particular needs.

System Accessories

Refer to the Setup illustration on page 5.

WARNING

Two accessories are required in your system: a bleed-type master air valve (D) and a fluid drain valve (J). These accessories help reduce the risk of serious injury including injection, splashing in the eyes, and injury from moving parts if you are adjusting or repairing the pump.

The bleed-type master air valve relieves air trapped between this valve and the pump after the air regulator is shut off. Trapped air can cause the pump to cycle unexpectedly. Locate the valve close to the pump.

The fluid drain valve assists in relieving fluid pressure in the displacement pump, hose, and gun. Triggering the gun to relieve pressure may not be sufficient.

Mounting Accessories

Mount the pump (A) to suit the type of installation planned. The pump dimensions and mounting hole layout are shown on page 22. Use 3/8 in. bolts, lock-washers and nuts to attach the pump firmly to the mounting.

Air and Fluid Hoses

Be sure all air and fluid hoses are properly sized and pressure-rated for your system. Use only grounded air and fluid hoses. Fluid hoses must have spring guards on both ends.

Connect a grounded fluid hose (K) to the pump's 1" npt(f) fluid outlet, using a suitable adapter.

Connect a fluid suction hose and tube (M) to the pump's 1-1/2" npt(f) fluid intake.

Use a grounded 3/4 in. I.D. (minimum) air hose (H) to supply air to the pump.

Air Line Accessories

Install the following accessories in the order shown in the Typical Installation, using adapters as necessary:

- **A pump runaway valve (B)** senses when the pump is running too fast and automatically shuts off the air to the motor. A pump which runs too fast can be seriously damaged. Install closest to the pump air inlet.
- **An air line lubricator (C)** provides automatic air motor lubrication.
- **A bleed-type master air valve (D)** is required in your system to relieve air trapped between it and the air motor when the valve is closed (see the **WARNING** at left). Be sure the bleed valve is easily accessible from the pump, and is located **downstream** from the air regulator.
- **An air regulator (E)** controls pump speed and outlet pressure by adjusting the air pressure to the pump. Locate the regulator close to the pump, but **upstream** from the bleed-type master air valve.
- **An air line filter (F)** removes harmful dirt and moisture from the compressed air supply.
- **A second bleed-type air valve (G)** isolates the air line accessories for servicing. Locate upstream from all other air line accessories.

Fluid Line Accessories

Install the following accessories in the positions shown in the Typical Installation, using adapters as necessary:

- **A fluid drain valve (J)** is required in your system to relieve fluid pressure in the hose and gun (see the **WARNING** at left). Install the drain valve pointing down, but so the handle points up when the valve is opened.
- **A spray gun (L)** dispenses the fluid. The gun shown in the Typical Installation is an airless spray gun.

Air Motor Exhaust

To route the air motor exhaust outside, remove the exhaust port plug and connect the hose to the 1-1/4 npt(f) exhaust port (N). Plug the 16 exhaust holes in the base of the motor with 1/4 in. size x 1/2 in. long self-tapping screws.

Setup

Grounding

⚠ WARNING

FIRE AND EXPLOSION HAZARD
Before operating the circulation package, ground the system as explained below. Also read the section **FIRE AND EXPLOSION HAZARD** on page 4.

1. *Pump*: use the ground wire and clamp (A, supplied). See Fig. 1. Loosen the grounding lug locknut (W) and washer (X). Insert one end of the ground wire (A) into the slot in lug (Z) and tighten the locknut securely. Connect the ground clamp to a true earth ground.

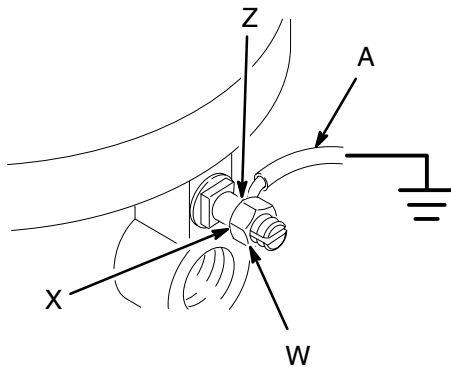

Fig. 1

0720

2. *Air and fluid hoses*: use only electrically conductive hoses.
3. *Air compressor*: follow manufacturer's recommendations.
4. *Spray gun/dispensing valve*: ground through connection to a properly grounded fluid hose and pump.
5. *Fluid supply container*: follow your local code.
6. *Object being sprayed*: follow your local code.
7. *Solvent pails used when flushing*: follow your local code. Use only metal pails, which are conductive, placed on a grounded surface. Do not place the pail on a nonconductive surface, such as paper or cardboard, which interrupts the grounding continuity.
8. *To maintain grounding continuity when flushing or relieving pressure*, hold a metal part of the spray gun firmly to the side of a grounded *metal* pail, then trigger the gun.

Operation

Pressure Relief Procedure

WARNING



INJECTION HAZARD

To reduce the risk of serious injury, including fluid injection, splashing in the eyes or on the skin, or moving parts, always follow the **Pressure Relief Procedure** whenever you:

- are instructed to relieve the pressure,
- shut off the pump,
- stop spraying,
- check or service any of the system equipment,
- or install or clean the spray tip/nozzle.

1. Lock the gun trigger safety.
2. Shut off the air supply to the pump.
3. Close the bleed-type master air valve (required in your system).
4. Unlock the gun trigger safety.
5. Hold a metal part of the gun firmly to the side of a grounded metal pail, and trigger the gun to relieve pressure.
6. Lock the gun trigger safety.
7. Open the drain valves (required in your system), having a container ready to catch the drainage.
8. Leave the drain valves open until you are ready to dispense again.

If you suspect that the spray tip/nozzle or hose is completely clogged, or that pressure has not been fully relieved after following the steps above, **very slowly** loosen the hose end coupling and relieve pressure gradually, then loosen completely. Now clear the tip/nozzle or hose.

WARNING



FIRE AND EXPLOSION HAZARD

Before flushing, read the section **FIRE, EXPLOSION, AND ELECTRIC SHOCK HAZARD** on page 4. Be sure the entire system and flushing pails are properly grounded. Refer to **Grounding** on page 7.



Flushing the Pump Before Using

The pump is tested with lightweight oil, which is left in to protect the pump parts. If the fluid you are using may be contaminated by the oil, flush it out with a compatible solvent before using the pump. If the pump is being used to supply a circulating system, allow the solvent to circulate until the pump is thoroughly flushed.

Flush the Pump Before Using

The pump is tested with lightweight motor oil, which is left in to protect the pump parts. If the fluid you are pumping may be contaminated by the oil, flush out the oil with a compatible solvent before using the pump. If the pump is being used to supply a circulating system, allow the solvent to circulate until the pump is thoroughly flushed.

WARNING



MOVING PARTS HAZARD

Moving parts can pinch or amputate your fingers or other body parts. When air is supplied to the motor, the air motor piston (located behind the air motor shield) moves. Therefore, **NEVER** operate the pump with the air motor shield removed.



COMPONENT RUPTURE HAZARD

To reduce the risk of overpressurizing your system, which could cause component rupture and serious injury, *never exceed the specified maximum air input pressure to the pump* (see **Technical Data** on page 23).

Refer to **Setup** on page 5.

Starting and Adjusting the Pump

Be sure the air regulator (E) and bleed-type master air valve (D) are closed. *Do Not Install The Spray Tip Yet!*

Connect a suction hose (M) to the pump's fluid inlet, or lower the pump into a fluid supply container. Hold a metal part of the spray gun (L) firmly to the side of a grounded metal pail and hold the trigger open. Then open the pump's bleed-type master air valve (D). Now slowly open the air regulator until the pump starts, about 40 psi (2.8 bar).

Cycle the pump slowly until all the air is pushed out, and fluid is flowing from the gun in a steady stream. Release the spray gun trigger and engage the safety latch. The pump should stall against pressure when the trigger is released.

Follow the **Pressure Relief Procedure** on page 8 above, then install the spray tip in the gun.

Operation

In a direct supply system, with the pump and lines primed and with adequate air pressure and volume supplied, the pump will start and stop as the spray gun is opened and closed. In a circulating system, the pump will run continuously and will speed up or slow down as supply demands until the air supply is shut off.

Use an adequately sized air regulator (E) to control the pump speed and the fluid pressure. See **Accessories** on page 20. Always use the lowest air pressure necessary to get the desired results. Higher pressures waste fluid and cause premature wear of the pump packings and spray tip.

Packing nut/Wet-cup

Keep the packing nut/wet-cup (S) half filled with Graco Throat Seal Liquid (TSL) or compatible solvent, to help prolong the packing life. Adjust the packing nut weekly with the wrench (supplied) so it is just tight enough to prevent leakage; do not overtighten. Always follow the **Pressure Relief Procedure** on page 8, before adjusting the packing nut.

CAUTION

Do not allow the pump to run dry. It will quickly accelerate to a high speed, causing damage. A pump runaway valve (B), which shuts off the air supply to the pump if the pump accelerates beyond the pre-set speed, is available. See **Setup** on page 5 and **Accessories** on page 20. If your pump is running too fast, stop it immediately and check the fluid supply. If the container is empty and air has been pumped into the lines, refill the container and prime the pump and the lines, or flush and leave it filled with a compatible solvent. Eliminate all air from the fluid system.

Shutdown and Care of the Pump

For overnight shutdown, follow the **Pressure Relief Procedure** on page 8. Always stop the pump at the bottom of the stroke to prevent the fluid from drying on the exposed displacement rod and damaging the throat packings.

Always flush the pump before the fluid dries on the displacement rod. Never leave water or water-based fluid in the pump overnight. First, flush with water or a compatible solvent, then with mineral spirits. Relieve the pressure, but leave the mineral spirits in the pump to protect the parts from corrosion.

Troubleshooting

WARNING

To reduce the risk of serious injury whenever you are instructed to relieve pressure, always follow the **Pressure Relief Procedure** on page 8.

Before servicing this equipment always make sure to **Relieve the pressure**.

NOTE: Check all possible problems and solutions before disassembling.

Problem	Cause	Solution
Pump fails to operate	Restricted line or inadequate air supply	Clear; increase air supply
	Obstructed fluid hose, gun, or dispensing valve	Open, clear*
	Exhausted fluid supply	Refill; purge all air from pump and fluid lines
	Fluid dried on displacement rod	Clean; always stop pump at bottom of stroke; keep wet-cup 1/2 filled with compatible solvent
	Damaged air motor	Service air motor (see 306968 or 307741)
Pump operates but output low on both strokes	Restricted line or inadequate air supply	Clear; increase air supply
	Obstructed fluid hose, gun, or dispensing valve	Open, clear*
	Exhausted fluid supply	Refill; purge all air from pump and fluid lines
	Air in displacement pump and hose	Reprime. See page 8.
	Packing nut too tight or too loose	Adjust. See page 8.
	Worn throat packings	Replace. See page 11.
Pump operates but output low on down stroke	Held open or worn intake valve	Clear; service. See page 11.
Pump operates but output low on up stroke	Held open or worn fluid piston valve or packings	Clear; service. See page 11.
Erratic or accelerated operation	Exhausted fluid supply	Refill; purge all air from pump and fluid lines
	Packing nut too tight	Adjust. See page 8.
	Held open or worn intake valve	Clear; service. See page 11.
	Held open or worn fluid piston valve or packings	Clear; service. See page 11.

* To determine if the fluid hose or gun/valve is obstructed, follow the **Pressure Relief Procedure** on page 8. Disconnect the fluid hose and place a container at the pump fluid outlet to catch any fluid. Turn on the air just enough to start the pump (about 20–40 psi [1.4–2.8 bar]). If the pump starts when the air is turned on, the obstruction is in the fluid hose or gun/valve.

Service

Repair Notes:

1. Packing Repair Kits are available. *For displacement pump 224545* (used on Model 218174), order Kit 224433. *For displacement pumps 220504 and 223600* (used on Models 220505 and 223601), order Kit 223658. Refer to the parts list for your displacement pump for information.

For the best results, use all the parts in the kit, even if the old ones still look good. The gland/packing stacks (130*) are preassembled. Do not disassemble the stacks when you install them.

2. A reference number marked with an asterisk, for example (117*), indicates that the part is included in the repair kit.
3. Clean all parts as you disassemble the pump and inspect them for wear or damage. Replace parts as necessary.

Displacement Pump Service

1. Disconnect the displacement pump from the air motor as described on page 11.
2. Unscrew the intake valve (119) from the pump housing (101). See Fig 3. Unscrew the elbow (19) from the intake valve (*Pump Models 218174 and 223601 only; see Fig 2*).
3. Remove the ball guide (118) and ball (120) from the intake valve (119). Remove the pin (116) from the ball guide (118), making note of which holes the pin is in. See Fig 3.
4. Loosen the throat packing nut (102), push the connecting rod (131) (model 220504 only) and displacement rod (103) down until you can grasp the piston (111), and pull the piston and the displacement rod out through the bottom of the pump housing (101).

NOTE: Do not remove the bushing (101a) from the pump housing (101) unless specific repairs to it or the pump housing are required. If the bushing (101a) must be removed from the pump housing, be sure to clean it thoroughly and carefully install the o-ring (101b) on the bushing. Apply Loctite® No. 70 to the threads of the bushing, reinstall it in the pump housing and torque to 325 ft-lb (440 N.m).

5. Secure the flats of the displacement rod (103) in a vise and screw the piston stud (111) out of the displacement rod. Remove the ball (112), retainer (106), glands, and packings.
6. Inspect the smooth inner surface of the cylinder sleeve (104) and the outer surface of the displacement rod (103). If the parts show any sign of scoring or damage, replace them; they will cause new packings to wear prematurely and cause leakage. Do not

remove the connecting rod (131) (model 220504 only) from the displacement rod (103) unless the displacement rod is being replaced. If that is necessary, save the connecting rod for use with the new displacement rod.

NOTE: If the sleeve (104) cannot be easily removed for replacement, contact Graco Technical Assistance (see back page). Be sure to install the new sleeve with the internally tapered end *down*. Install a new gasket (105*) when replacing the sleeve.

7. If the connecting rod (131) (model 220504 only) was removed, apply thread sealant and screw it into the displacement rod (103). Torque to 100–110 ft-lb (135–150 N.m).
8. Lubricate the gland/packing stack (130*) and install it on the piston stud (111), *with the lips of the v-packings facing up*. **Do not disassemble the stack**. Install the seal retainer (106*) on top of the gland/packing stack. See Fig 3.
9. Place the ball (112*) on the piston stud (111) and screw the stud into the displacement rod (103), torquing it to 165–185 ft-lb (225–250 N.m).
10. Remove the packing nut (102). Remove the glands and packings from the throat of the pump housing (101). Thoroughly clean the throat of the pump housing.

NOTE: When installing the packing stack in the pump throat, remove the shims from the stack. When installing the stack on the piston, leave the shims in place.

11. Lubricate the gland/packing stack (130*) and install it in the throat, *with the lips of the v-packings facing down*. **Do not disassemble the stack**. See Fig 3.
12. Loosely install the packing nut (102).
13. Carefully insert the displacement rod (103) up through the bottom of the pump housing (101). Push it all the way up until the connecting rod (131) (model 220504 only) protrudes from the packing nut (102).
14. Install a new o-ring (117*) on the intake valve (119) and then install the pin (116) in the ball guide (118), making sure the pin is in the correct set of holes. Install the ball (120*) and ball guide (118) in the intake valve (119). Screw the intake valve (119) into the pump housing (101), torquing to 90–100 ft-lb (122–136 N.m). *On Models 218174 and 223601 only*, reinstall the elbow (19) in the intake valve. See Fig 2.
15. Tighten the packing nut (102) just enough to stop leakage, but no tighter.
16. Reconnect the displacement pump to the air motor as described on page 11.

Service

Important: The gland/packing stacks are preassembled. The stacks include 0 to 3 shims. When installing the stack in the pump throat, remove the shims. When installing the stack on the piston, leave the shims in place, to ensure the required piston stack height.

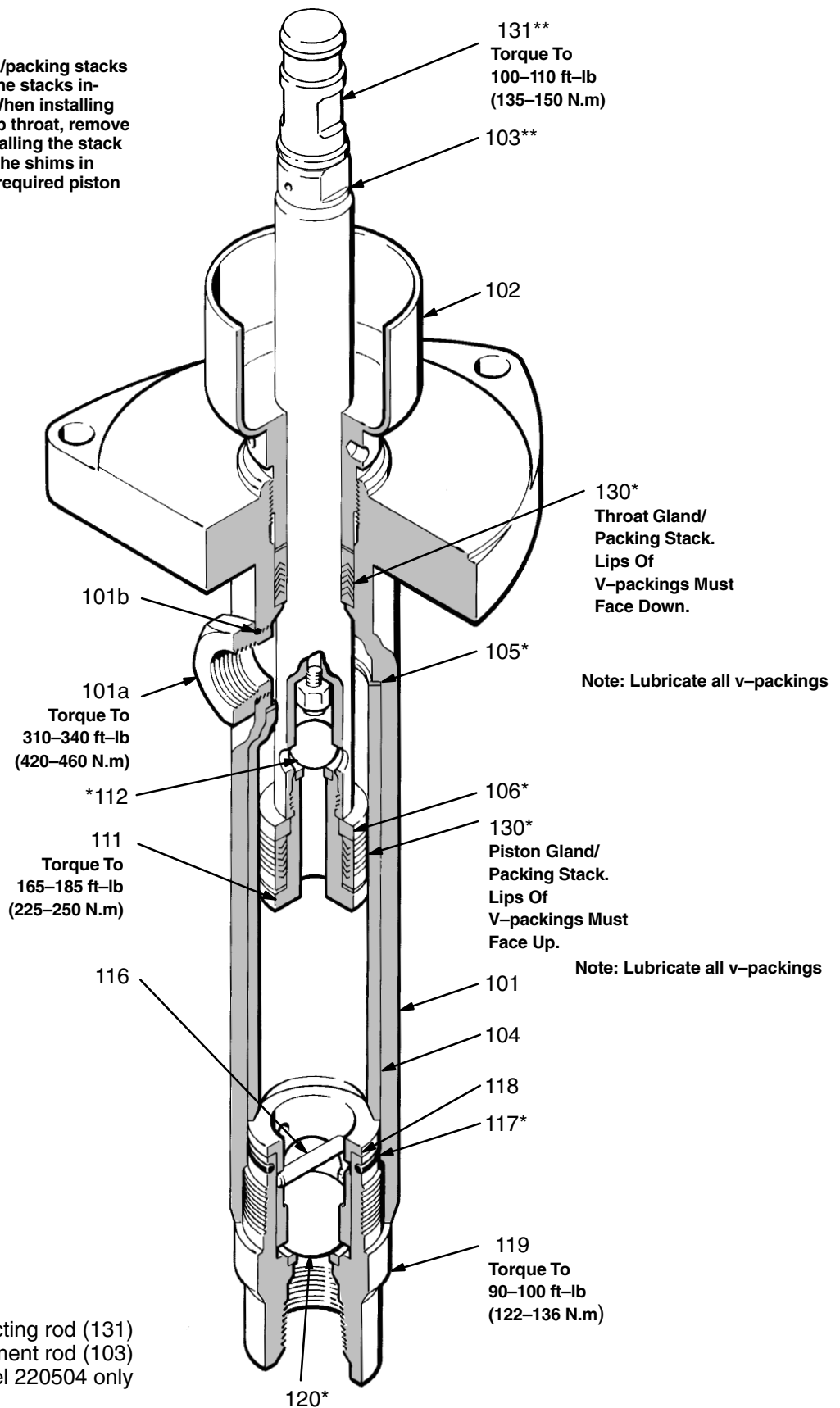

** Separate connecting rod (131) and displacement rod (103) used on model 220504 only

Fig 3

Parts

Model 218174, Series E

63:1 Ratio King Pump
Includes items 1 to 19

Model 237002, Series A

63:1 Ratio Reduced Icing
Quiet King Pump
Includes items 1 to 19

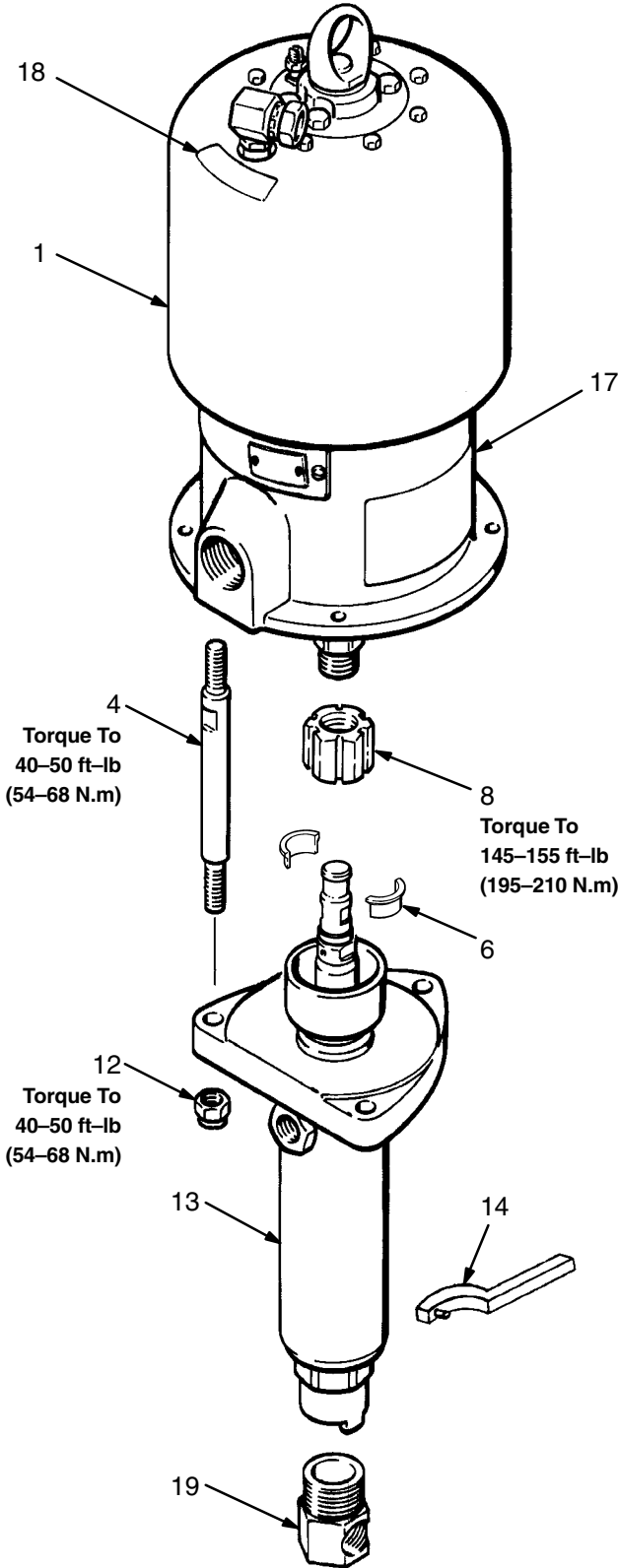

Ref. No.	Part No.	Description	Qty.
1	207647	AIR MOTOR (used on 218174) See 306968 for parts	1
	237000	AIR MOTOR (used on 237002) See 307741 for parts	1
4	167911	ROD, tie; 7" (178 mm), shoulder-to-shoulder	3
6	184129	COUPLER	2
8	186925	NUT, coupling	1
12	101712	NUT, lock; 5/8–11	3
13	224545	DISPLACEMENT PUMP ASSY See pages 16 & 17 for parts	1
14	102176	WRENCH	1
15	172479	TAG, warning (not shown)	1
17	176529	PLATE, warning	1
18	180189	LABEL	1
19	180180	ELBOW, street, 90° ; 1–1/2 npt(m) x 1 npt(f)	1

306 numbers in descriptions refer to separate instruction manuals.

Parts

Model 223601, Series A

With Quiet Air Motor, Severe-Duty Displacement Pump, and Stainless Steel Glands, Intake Housing, Piston Valve and Ball Stop
Includes items 1-19

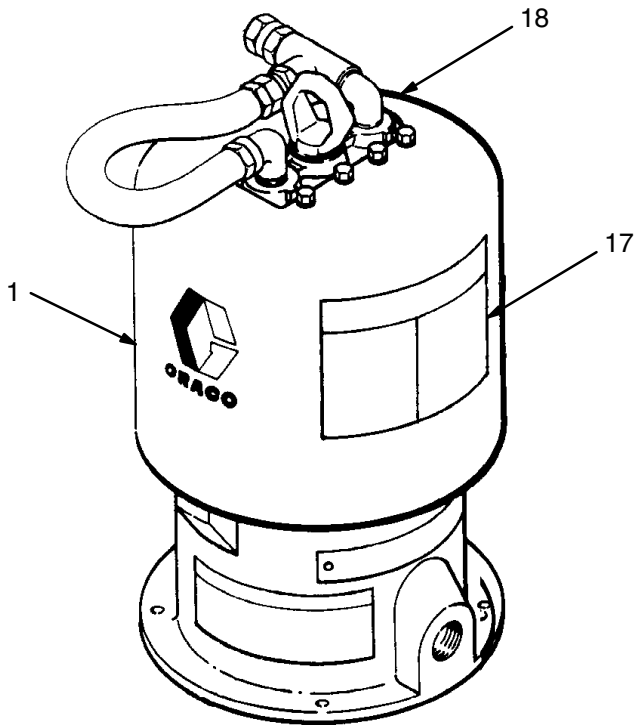

Ref. No.	Part No.	Description	Qty.
1	220106	AIR MOTOR See 307741 for parts	1
4	167911	ROD, tie; 7" (178 mm), shoulder-to-shoulder	3
6	184129	COUPLER	2
8	186925	NUT, coupling	1
12	101712	NUT, lock; 5/8-11	3
13	223600	DISPLACEMENT PUMP ASSY See pages 20 & 21 for parts	1
14	102176	WRENCH	1
17	176529	PLATE, warning	1
18	180189	LABEL	1
19	180180	ELBOW, street, 90° ; 1-1/2 npt(m) x 1 npt(f)	1

306 numbers in descriptions refer to separate instruction manuals, supplied.

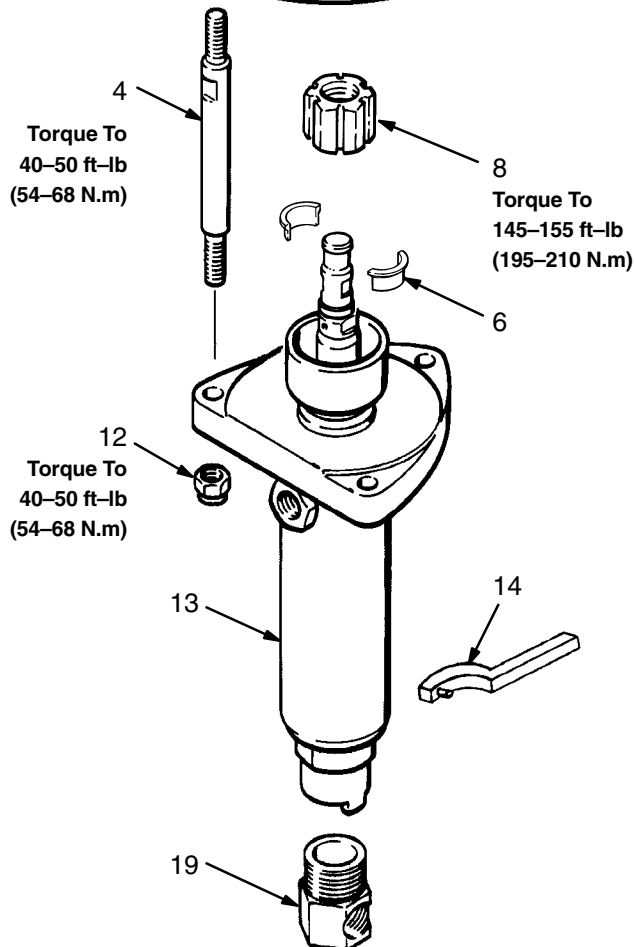

Parts

Model 224545, Series A
 Severe-Duty Displacement Pump
 With Leather and PTFE Packings
 Includes items 101 to 131

Important: The gland/packing stacks are preassembled. The stacks include 0 to 3 shims. When installing the stack in the pump throat, remove the shims. When installing the stack on the piston, leave the shims in place, to ensure the required piston stack height.

*130
 Lips Of
 V-packings
 Must
 Face
 Down.

Note: Lubricate all v-packings

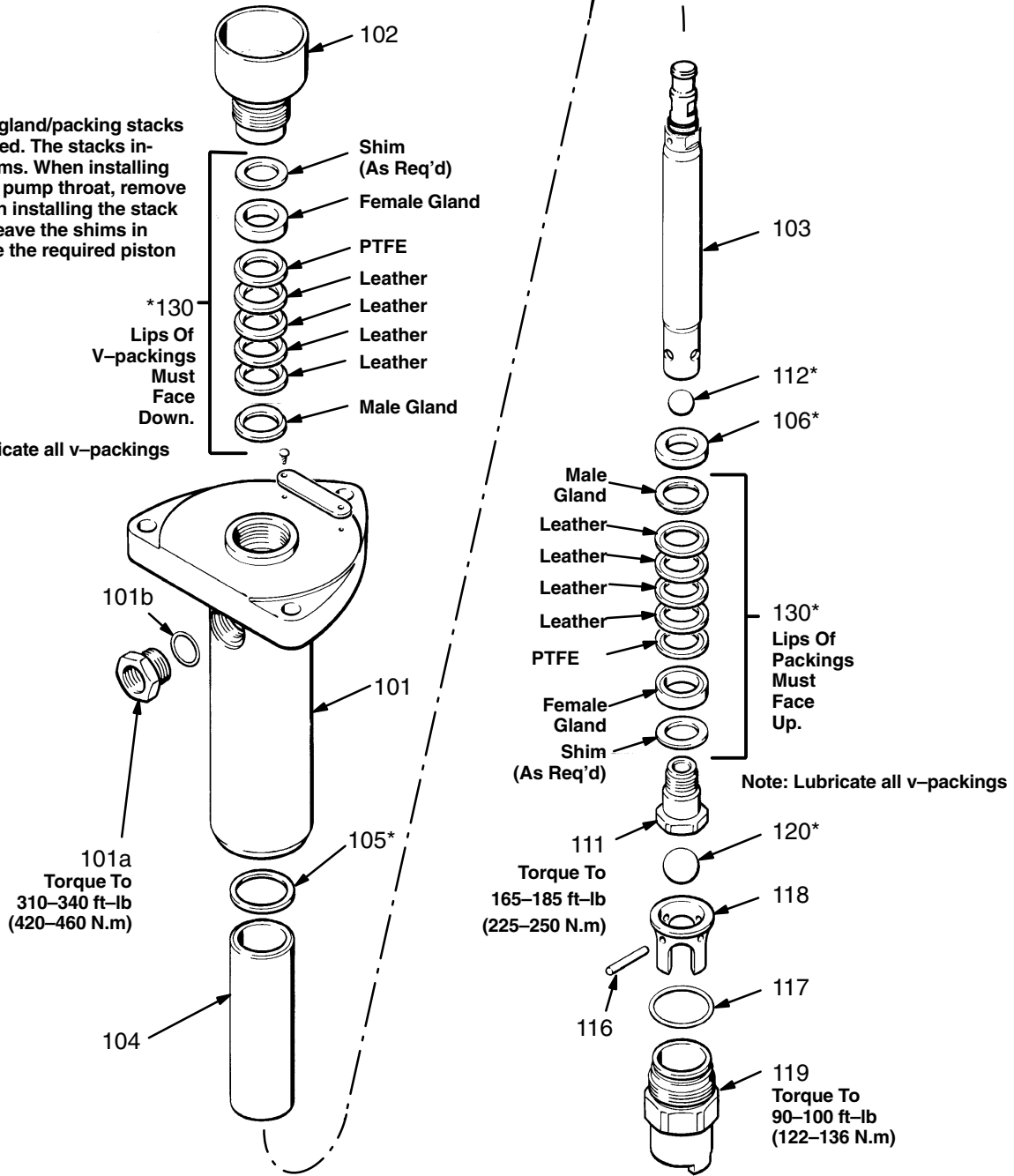

Parts

Model 224545, Series A

Severe-Duty Displacement Pump
With Leather and PTFE Packings
Includes items 101 to 131

Ref. No.	Part No.	Description	Qty.
101	218346	HOUSING, pump; carbon steel Includes items 101a and 101b	1
101a	180188	. BUSHING, adapter; carbon steel; 3/4 npt(f) x 1-5/16" (m)	1
101b	102595	. O-RING; PTFE	1
102	205514	NUT, packing, w/wet-cup; carbon steel	1
103	236279	ROD, displacement; stainless steel	1
104	178900	SLEEVE, housing; stainless steel	1
105	164652*	GASKET; PTFE	1
106	186209*	RETAINER, seal; stainless steel	1
111	223602	STUD, piston; stainless steel with tungsten carbide seat	1
112	112264*	BALL; 3/4" dia.; carbide	1
116	172399	PIN, ball stop, intake; stainless steel	1
117	166073*	O-RING; PTFE	1
118	178761	GUIDE, ball; carbon steel	1
119	217476	INTAKE VALVE; carbon steel with tungsten carbide seat	1
120	101178*	BALL; 1-1/4" dia.; carbon steel	1
130	223483*	GLAND/PACKING STACK	2

* Included in standard repair kit 224433. Some parts in kit are different from those in pump; see list at right.

Standard Repair Kit 224433

with Leather and PTFE packings
Consists of:

Part No.	Description	Qty
100103	Cotter Pin (for use with old style connecting rod and coupling nut)	1
112264	Ball, piston; carbide	1
101178	Ball, intake; cst	1
164652	Gasket; PTFE	1
186209	Retainer, seal	1
166073	O-Ring; PTFE	1
223483	Gland/Packing Stack	2

Available Gland/Packing Stacks

(To convert pump to alternative packing material)

223481 UHMWPE and PTFE

223482 All PTFE

Optional 166730 Rubber V-packings (10 req'd)

For converting to rubber packed pump.
Install in place of 8 Leather, 2 PTFE packings.

Parts

Model 223600, Series A

Severe-Duty Displacement Pump with UHMWPE and Leather Packings, Stainless Steel Glands, Intake Housing, Piston Valve and Ball Stop
Includes items 101 to 131

Important: The gland/packing stacks are preassembled. The stacks include 0 to 3 shims. When installing the stack in the pump throat, remove the shims. When installing the stack on the piston, leave the shims in place, to ensure the required piston stack height.

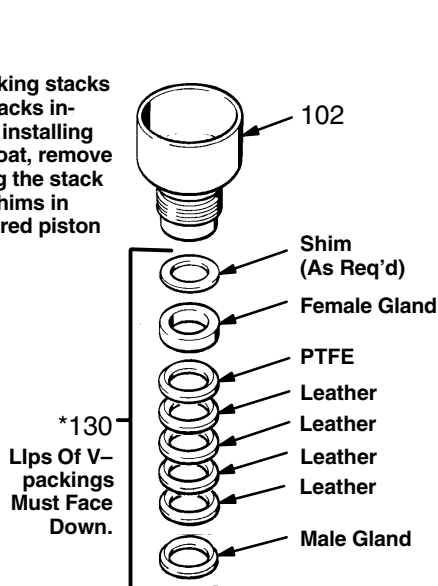

Note: Lubricate all v-packings

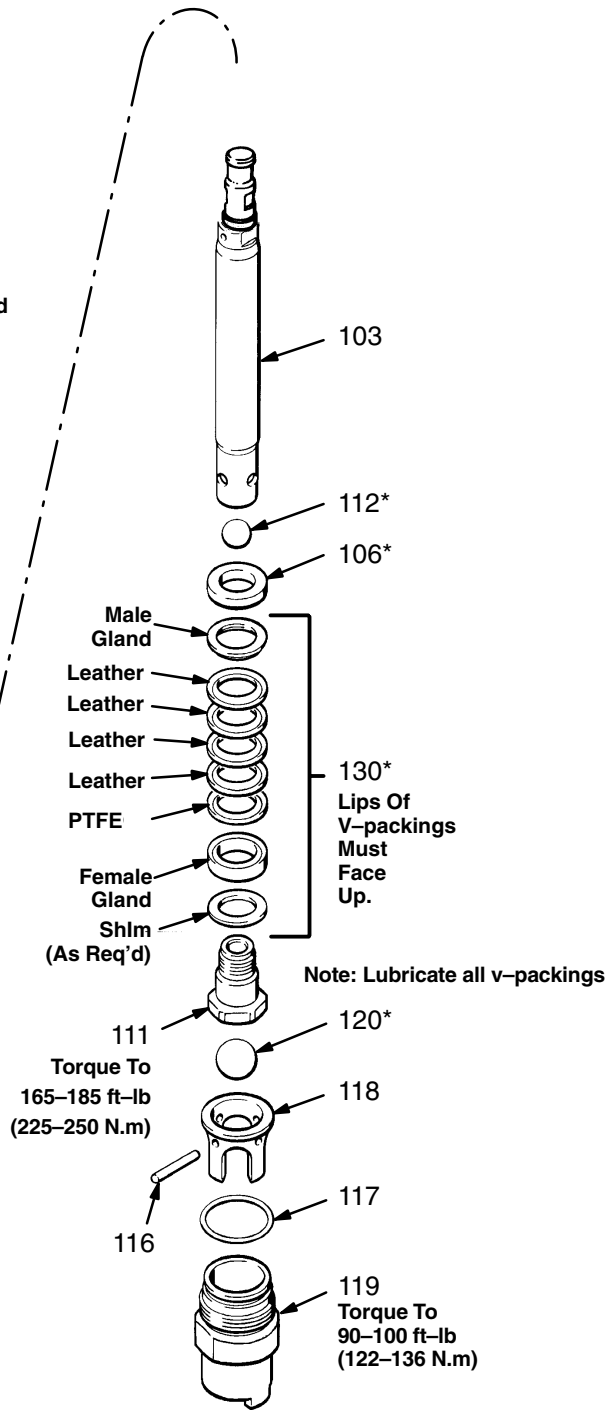
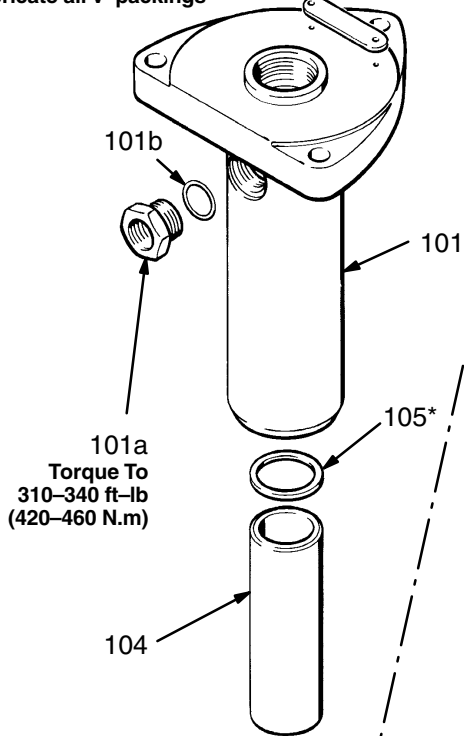

Note: Lubricate all v-packings

Parts

Model 223600, Series A

Severe-Duty Displacement Pump with UHMWPE and Leather Packings,
Stainless Steel Glands, Intake Housing, Piston Valve and Ball Stop
Includes items 101 to 131

Ref. No.	Part No.	Description	Qty.
1	100103*	PIN, cotter; 0.12" (3.2 mm) dia.; 1.5" (38 mm) long	2
101	218346	HOUSING, pump; carbon steel Includes items 101a and 101b	1
101a	180188	. BUSHING, adapter; carbon steel; 3/4 npt(f) x 1-5/16" (m)	1
101b	102595	. O-RING; PTFE	1
102	205514	NUT, packing, w/wet-cup; carbon steel	1
103	236279	ROD, displacement; stainless steel	1
104	178900	SLEEVE, housing; stainless steel	1
105	164652*	GASKET; PTFE	1
106	186209*	RETAINER, seal; stainless steel	1
111	223602	STUD, piston; stainless steel, with tungsten carbide seat	1
112	109223*	BALL; 3/4" dia.; stainless steel	1
116	186152	PIN, ball stop, intake; stainless steel	1
117	166073*	O-RING; PTFE	1
118	186158	GUIDE, ball; stainless steel	1
119	223563	INTAKE VALVE; stainless steel, with tungsten carbide seat	1
120	109219*	BALL; 1-1/4" dia.; stainless steel	1
130	235882*	GLAND/PACKING STACK	2

* Included in standard repair kit 223658.

Standard Repair Kit 223658 with UHMWPE and Leather packings Consists of:

Part No.	Description	Qty
100103	Cotter Pin (for use with old style connecting rod and coupling nut)	1
109223	Ball, piston; stainless steel	1
109219	Ball, intake; stainless steel	1
164652	Gasket; PTFE	1
186209	Retainer, seal	1
166073	O-Ring; PTFE	1
235882	Gland/Packing Stack	2

Optional 166730 Rubber V-packings (10 req'd)

For converting to rubber packed pump.
Install in place of 4 Leather, 6 UHMWPE packings.

Accessories

Use Only Genuine Graco Parts and Accessories

Must be purchased separately.

Grounding Clamp 103538

Ground Wire 208950

25 ft (7.6 m) long,
12 gauge (1.5 mm²)

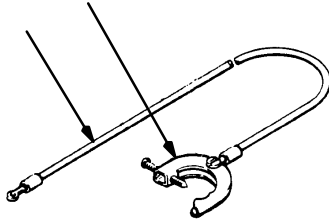

Air Line Lubricator

250 psi (17.5 bar) Maximum Working Pressure

214849 16 oz (0.48 liter) bowl capacity.

3/4 npt(f) inlet and outlet

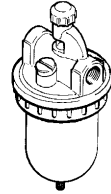

Bleed-type Master Air Valve

300 psi (21 bar) Maximum Working Pressure

107141 3/4 npt(m) inlet x 3/4 npt(f) outlet

Relieves air trapped in the air line between the pump air inlet and this valve when closed.

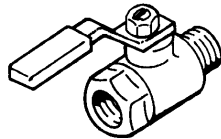

Air Pressure Regulator Kit 218315

175 psi (12 bar) Maximum Working Pressure

0–79 psi (0–5.4 bar) Regulated Pressure Range

Includes air regulator, gauge, bleed-type master air valve, hose and swivel inlet.

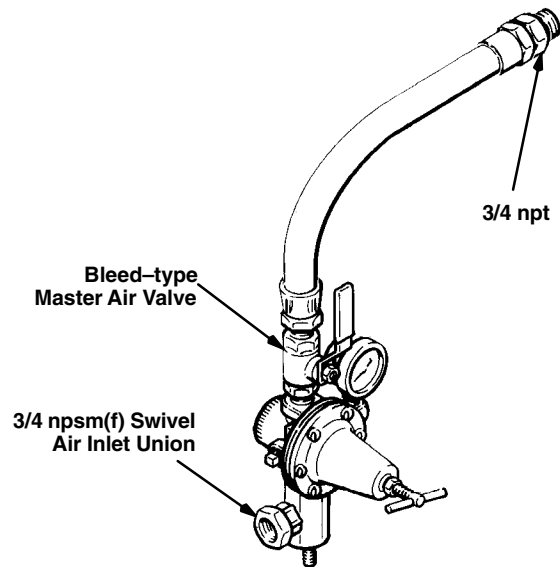

Pump Runaway Valve 215362

180 psi (12 bar) Maximum Working Pressure

Shuts off air supply to the pump if the pump accelerates beyond the pre-adjusted setting due to an empty supply container, interrupted fluid supply to the pump, or excessive cavitation. 3/4 npt(f) inlet and outlet.

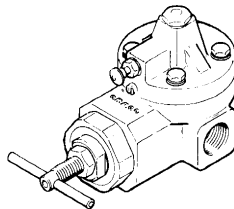

Air Line Filter

250 psi (17.5 bar) Maximum Working Pressure

106150 3/4 npt(f) inlet and outlet

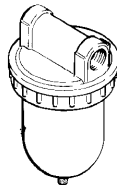

Air Regulator 180187

300 psi (21 bar) Maximum Working Pressure

0–79 psi (0–5.4 bar) Regulated Pressure Range

3/4 npt(f) inlet and outlet.

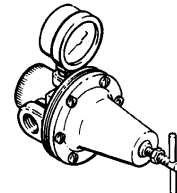

Accessories

Grounded 3/4 in. (19 mm) Buna–N Air Hose 175 psi (12 bar) Maximum Working Pressure

Part No.	ID	Length	Thd. Size
208610	3/4" (19 mm)	6 ft (1.8 m)	3/4 npt(m)
205548	3/4" (19 mm)	15 ft (4.5 m)	3/4 npt(m)
208611	3/4" (19 mm)	25 ft (7.6 m)	3/4 npt(m)

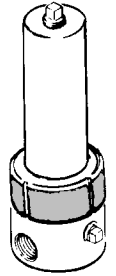

Grounded Nylon Fluid Hose 5000 psi (345 bar) Maximum Working Pressure

Part No.	ID	Length	Thd. Size
214914	1/4" (6.3 mm)	25 ft (7.6 m)	1/4 npsm(f) swivel
214915	1/4" (6.3 mm)	50 ft (15.2 m)	1/4 npsm(f) swivel
215247	3/8" (9.5 mm)	6 ft (1.8 m)	3/8 npt(m)
215244	3/8" (9.5 mm)	25 ft (7.6 m)	3/8 npt(m)
215245	3/8" (9.5 mm)	50 ft (15.2 m)	3/8 npt(m)
215246	3/8" (9.5 mm)	100 ft (30.4 m)	3/8 npt(m)

Fluid Drain Valve

5000 psi (345 bar) Maximum Working Pressure
Open to relieve fluid pressure in hose and gun/valve.

- 210657 1/4 npt (mbe)
210658 3/8 npt (mbe)
210659 1/4 npt x 3/8 npt (mbe)

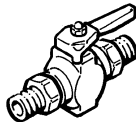

Director Valve 214711

5000 psi (345 bar) Maximum Working Pressure
For use as drain valve or fluid director valve in circulating systems. 1/4 npt(m).

High Pressure Fluid Filter 214625

5000 psi (345 bar) Maximum Working Pressure
3/4 npt(f) inlet; 3/8 npt(f) and 1/2 npt(f) outlets.

Pipe Nipple 175013

5000 psi (345 bar) Maximum Working Pressure
For mounting filter 214625 on pump fluid outlet.
3/4 npt

Swivel 157785

5000 psi (345 bar) Maximum Working Pressure
For mounting filter 214625 on pump fluid outlet.
3/4 npt(m) x 3/4 npsm(f) swivel.

Wall Bracket 206221

For mounting the King Pump to a wall.

Portable Cart 218028

For portable pump mounting.

Suction Hose 214959

Used with Suction Tube 208332, to draw fluid from a 55 gal. (200 liter) drum.
6 ft (1.8 m) long, coupled 1" npt (mbe), nylon.

55 GAL. (200 Liter) Suction Tube 208332

Use with Suction Hose 214959, to draw fluid from a 55 gal. (200 liter) drum. Consists of:

Part No.	Description	Qty
100220	THUMBSCREW	1
176684	ADAPTER, bung	1
156592	TUBE, riser	1
156593	O-RING; buna–N	1
159100	RETAINER, screen	1
161377	SCREEN, filter	1
159101	NUT, screen retainer	1
169529	ELBOW, 90°; 1" npt x 1–1/2 uns–2B thread	1

Street Elbow 180180

Use with Suction Kit 208332; 1–1/2" npt(m) x 1" npt(f)

Graco Throat Seal Liquid

Non–evaporating solvent for wet–cup.

206995 1 quart (0.95 liter)

206996 1 gallon (3.8 liter)

Dimensions

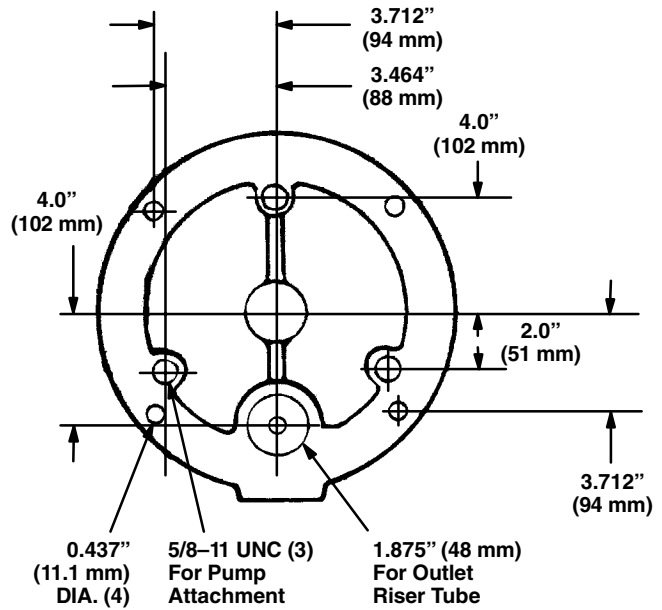
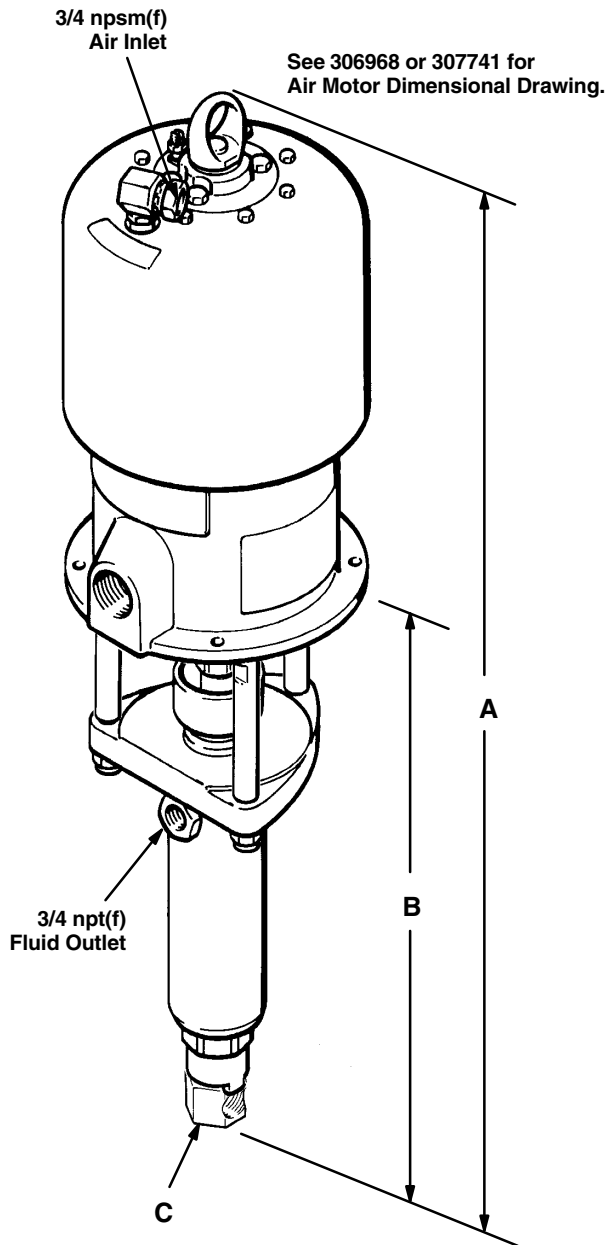

Mounting Hole Layout

Pump Model	A	B	C
218174	44.464 in. (1130 mm)	23.213 in. (590 mm)	1" npt(f) Fluid Inlet
220505	42.344 in. (1076 mm)	21.093 in. (536 mm)	1-1/2" npt(f) Fluid Inlet
223601	44.464 in. (1130 mm)	23.213 in. (590 mm)	1" npt(f) Fluid Inlet

Technical Data

Air operating range 40–79 psi (3–5.4 bar)
 Air consumption . . . approx. 60 scfm (1.7 m³/min) at 1 gpm (3.8 liter/min) at 79 psi (5.4 bar)
 Maximum fluid working pressure 5000 psi (345 bar) at 79 psi (5.4 bar) air pressure
 Cycles per gallon (3.8 liters) 21
 Maximum recommended pump speed (continuous duty) 50 cycles/min
 Air inlet size 3/4 npsm(f)
 Fluid outlet size 3/4 npt(f)
 Wetted parts *Model 224545 Displacement Pump:* 304 and 17–4 PH Stainless Steel;
 Zinc–Plated Carbon Steel; Chrome Plating; Leather; PTFE
Model 220504 Displacement Pump: 304 and 17–4 PH Stainless Steel;
 Zinc–Plated Carbon Steel; Chrome Plating; Leather; PTFE;
 Ultra–High Molecular Weight Polyethylene
Model 223600 Displacement Pump: 304, 329, and 17–4 PH Stainless Steel;
 Zinc–Plated Carbon Steel; Chrome Plating; Leather; PTFE

Weight approx. 95 lb (43 kg)

Loctite® is a registered trademark of the Loctite Corporation.

KEY: Fluid Outlet Pressure – Black Curves
 Air Consumption – Gray Curves

NOTE: Pump may be operated continuously to shaded area.

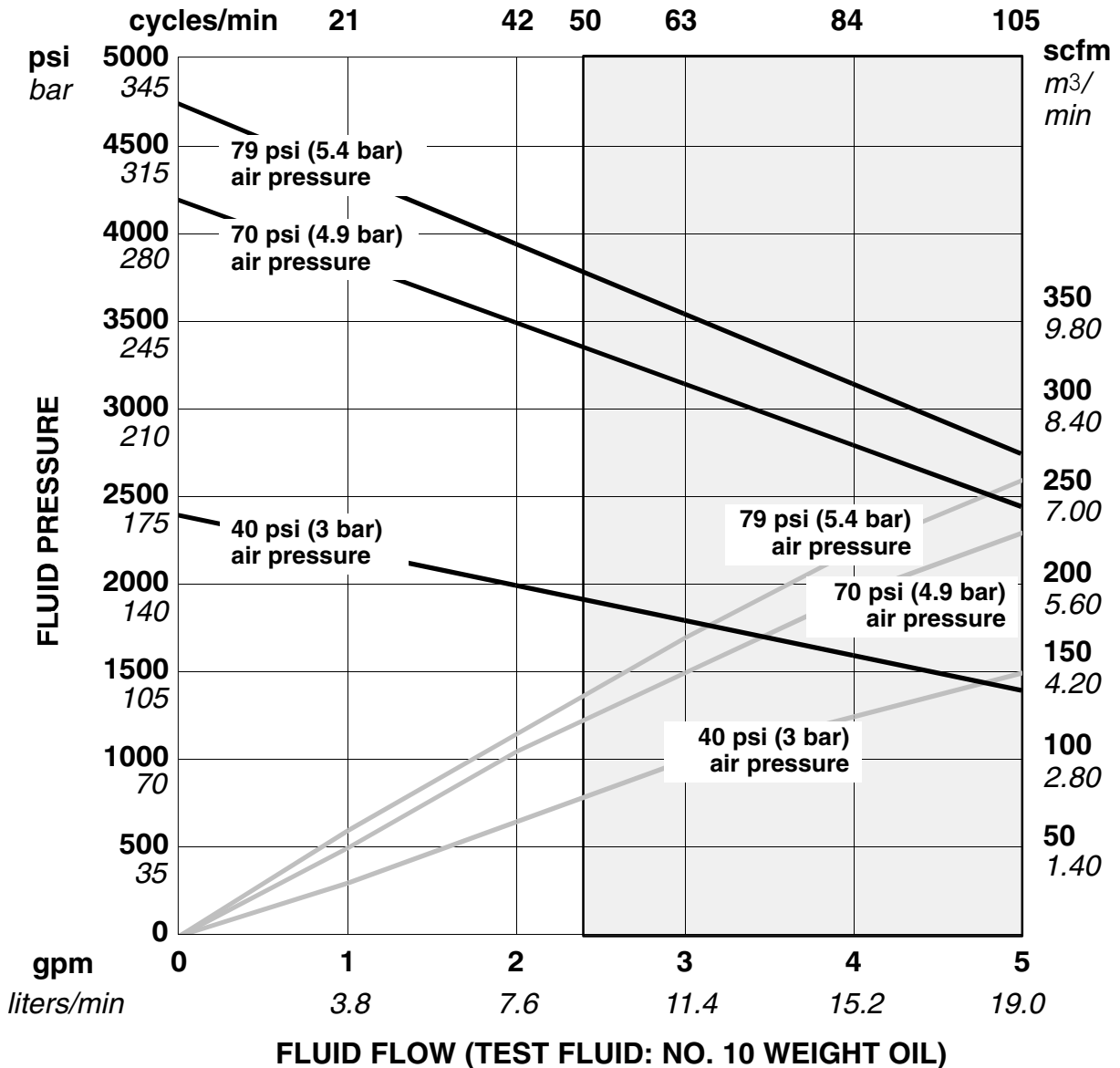

To find Fluid Outlet Pressure (bar/psi) at a specific fluid flow (lpm/gpm) and operating air pressure (bar/psi):
 1. Locate desired flow along bottom of chart.
 2. Follow vertical line up to intersection with selected fluid outlet pressure curve (black). Follow left to scale to read fluid outlet pressure.

To find Pump Air Consumption (m³/min or scfm) at a specific fluid flow (lpm/gpm) and air pressure (bar/psi):
 1. Locate desired flow along bottom of chart.
 2. Read vertical line up to intersection with selected air consumption curve (gray). Follow right to scale to read air consumption.

Graco Standard Warranty

Graco warrants all equipment manufactured by Graco and bearing its name to be free from defects in material and workmanship on the date of sale by an authorized Graco distributor to the original purchaser for use. With the exception of any special, extended, or limited warranty published by Graco, Graco will, for a period of twelve months from the date of sale, repair or replace any part of the equipment determined by Graco to be defective. This warranty applies only when the equipment is installed, operated and maintained in accordance with Graco's written recommendations.

This warranty does not cover, and Graco shall not be liable for general wear and tear, or any malfunction, damage or wear caused by faulty installation, misapplication, abrasion, corrosion, inadequate or improper maintenance, negligence, accident, tampering, or substitution of non-Graco component parts. Nor shall Graco be liable for malfunction, damage or wear caused by the incompatibility of Graco equipment with structures, accessories, equipment or materials not supplied by Graco, or the improper design, manufacture, installation, operation or maintenance of structures, accessories, equipment or materials not supplied by Graco.

This warranty is conditioned upon the prepaid return of the equipment claimed to be defective to an authorized Graco distributor for verification of the claimed defect. If the claimed defect is verified, Graco will repair or replace free of charge any defective parts. The equipment will be returned to the original purchaser transportation prepaid. If inspection of the equipment does not disclose any defect in material or workmanship, repairs will be made at a reasonable charge, which charges may include the costs of parts, labor, and transportation.

THIS WARRANTY IS EXCLUSIVE, AND IS IN LIEU OF ANY OTHER WARRANTIES, EXPRESS OR IMPLIED, INCLUDING BUT NOT LIMITED TO WARRANTY OF MERCHANTABILITY OR WARRANTY OF FITNESS FOR A PARTICULAR PURPOSE.

Graco's sole obligation and buyer's sole remedy for any breach of warranty shall be as set forth above. The buyer agrees that no other remedy (including, but not limited to, incidental or consequential damages for lost profits, lost sales, injury to person or property, or any other incidental or consequential loss) shall be available. Any action for breach of warranty must be brought within two (2) years of the date of sale.

Graco makes no warranty, and disclaims all implied warranties of merchantability and fitness for a particular purpose in connection with accessories, equipment, materials or components sold but not manufactured by Graco. These items sold, but not manufactured by Graco (such as electric motors, switches, hose, etc.), are subject to the warranty, if any, of their manufacturer. Graco will provide purchaser with reasonable assistance in making any claim for breach of these warranties.

In no event will Graco be liable for indirect, incidental, special or consequential damages resulting from Graco supplying equipment hereunder, or the furnishing, performance, or use of any products or other goods sold hereto, whether due to a breach of contract, breach of warranty, the negligence of Graco, or otherwise.

FOR GRACO CANADA CUSTOMERS

The parties acknowledge that they have required that the present document, as well as all documents, notices and legal proceedings entered into, given or instituted pursuant hereto or relating directly or indirectly hereto, be drawn up in English. Les parties reconnaissent avoir convenu que la rédaction du présente document sera en Anglais, ainsi que tous documents, avis et procédures judiciaires exécutés, donnés ou intentés à la suite de ou en rapport, directement ou indirectement, avec les procédures concernées.

Graco Information

TO PLACE AN ORDER, contact your Graco distributor, or call this number to identify the distributor closest to you:

1-800-367-4023 Toll Free

612-623-6921

612-378-3505 Fax

*All written and visual data contained in this document reflects the latest product information available at the time of publication.
Graco reserves the right to make changes at any time without notice.*

Sales Offices: Minneapolis, Detroit
International Offices: Belgium, Korea, Hong Kong, Japan

GRACO INC. P.O. BOX 1441 MINNEAPOLIS, MN 55440-1441

www.graco.com

PRINTED IN USA 307663 08/1983, Revised 09/2003