

# INSTRUCTIONS-PARTS LIST



307755G



**Important Safety Instructions**  
Read all warnings and instructions in this manual.  
Save these instructions.

## PRESSURE ROLLER FRAMES & COVERS

3000 psi (210 bar) Maximum Working Pressure

Always operate your pump at the lowest pressure needed for sufficient paint supply to roller.

224268 12 Inch Roller Frame & Diffuser  
218935 9 Inch Roller Frame & Diffuser  
220234 3 Inch Roller Frame & Diffuser

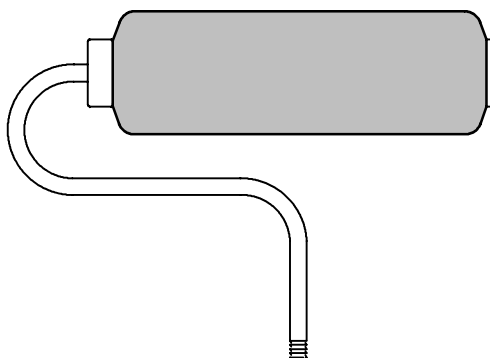

### ACCESSORIES

Must be purchased separately.

#### Roller Covers

Description/Roller Size	3 Inch	9 Inch	12 Inch
3/8 in. (9 mm) nap, for smooth surfaces	None	107589	None
1/2 in. (12 mm) nap, for semi-rough to smooth	None	107590	186944
3/4 in. (19 mm) nap, for semi-rough surfaces	None	107591	186945
1-1/4 in. (32 mm) nap, for rough surfaces	None	107592	186946

5000 psi (350 bar) Maximum Working Pressure

For coupling roller frame directly to 1/4 npt(m) outlet of roller valve or other dispensing valve or gun.

## WARNING

Be sure all operators of this equipment read, understand, and follow the warnings and instructions in the manuals for all painting equipment and this manual.

### AVOID POWER LINES

Avoid contact with any power lines! Contact with power lines could cause extremely serious bodily injury, including burns or electrocution.

### PRESSURE RELIEF PROCEDURE

To reduce the risk of serious bodily injury from fluid injection, splashing in the eyes, injury from moving parts, or property damage, always follow this procedure whenever you stop painting, and before checking, changing or repairing any part of the paint system.

1. Engage the dispensing valve/gun safety latch.
2. Shut off the power to the pump.
3. Open the fluid drain valve (required in high pressure systems to help relieve pressure).
4. Disengage the dispensing valve/gun safety device and trigger the gun.
5. Engage the dispensing valve/gun safety device.

This pressure relief procedure may be different than the one supplied with your pump or paint dispensing valve/gun. Use this procedure ONLY when using this Pressure Roller Equipment. At other times, relieve the pressure exactly as stated in your separate pump or paint dispensing valve/gun instruction manual.

### ELECTRICAL GROUNDING

To reduce the risk of static sparking which can cause fire or explosion and result in serious bodily injury and property damage, be sure your entire system and the object you are painting are properly grounded.

Read and follow all grounding instructions in your separate pump and paint gun instruction manual, and follow all local codes regarding electrical grounding.

### AVOID OVERPRESSURIZING EQUIPMENT

Operate your pump at the lowest pressure needed for sufficient paint supply to the roller. The pressure is safer at lower pressures, and the paint is easier to control.

Do not attempt to modify the roller frame or to use parts which are not designed to be used with this equipment. Modifying parts can cause them to overpressurize which can result in component rupture or explosion, and cause serious bodily injury, including fluid injection and splashing in the eyes, or property damage.

Never exceed the maximum working pressure of the lowest rated component in your system, including this pressure roller frame, the dispensing valve/gun, extension tubes, hoses and pump/sprayer. Overpressurizing equipment can cause component rupture, fire or explosion and result in serious bodily injury, including injection, splashing in the eyes and property damage.

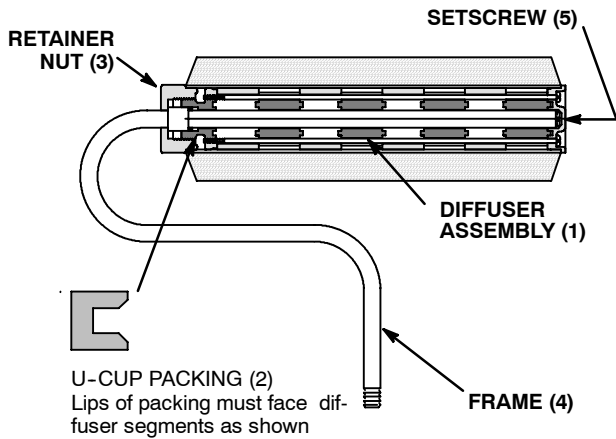

Fig 1

0244

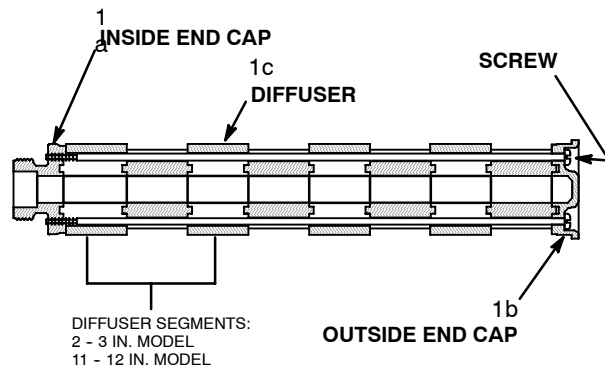

Fig 2

0245

### Installing and Removing a Roller Cover (See Fig 1)

**Installation:** Hold the diffuser assembly and unscrew the retainor nut. Remove the diffuser assembly from the roller frame. Slide the cover over the diffuser assembly, place the assembly on the roller frame, and reinstall the nut. Do not to overtighten the nut.

**Removal:** Hold the cover and unscrew the retainor nut. Slide the cover and diffuser assembly off the roller frame, and press on the end of the diffuser assembly to separate it from the cover.

### Cleaning the Roller Diffuser (See Fig 1 and 2)

**For water-base paint:** Vigorously shake the diffuser in a bucket of hot soapy water to remove wet paint.

**For oil-base paint:** Use a compatible solvent. Use a brass wire brush to remove dried paint.

**For further cleaning:** Remove the roller cover. Remove the two screws. Pull off the outside end cap. Disassemble all parts and clean thoroughly in a compatible solvent.

**To reassemble:** Install the inside end cap onto the roller frame. Slide all diffusers onto the roller frame. Twist and press the last diffuser to snap the pieces together. Install the outside end cap and the two screws. Holding the inside end cap, press on the screws and rotate the diffusers to seat the screws. Tighten the screws into the inside end cap; don't overtighten.

## PARTS LIST

**Model 224268, 12 in. Frame & Diffuser**  
**Model 218935, 9 in. Frame & Diffuser**  
**Model 220234, 3 in. Frame & Diffuser**

Includes items 1-5

REF NO.	PART NO.	DESCRIPTION	QTY
1		DIFFUSER ASSEMBLY	
	220233	3 in. model	1
	218943	9 in. model	1
	224377	12 in. model	1
1a	275643	END CAP, inside	1
1b	275645	END CAP, outside	1
1c	275673	DIFFUSER SEGMENT	
		3 in. model	2
		9 in. model	8
		12 in. model	11
2	108808	PACKING, U-CUP	1
3	183420	RETAINER NUT	1
4		ROLLER FRAME	
	220235	3 in. model	1
	218582	9 in. model	1
	224378	12 in. model	1
5	101983	SETSCREW	1

**Wetted Parts** Polyethylene, Acetal Homopolymer, Plated Steel, Viton®, Neoprene

### SERVICE INFORMATION NOTE:

Added Model 224268, 12 in. Frame and Diffuser.  
 Ref No. 5 Setscrew 101983 was 108226.

## GRACO WARRANTY AND DISCLAIMERS

### WARRANTY

Graco warrants all equipment manufactured by it and bearing its name to be free from defects in material and workmanship on the date of sale by an authorized Graco distributor to the original purchaser for use. As purchaser's sole remedy for breach of this warranty, Graco will, for a period of twelve months from the date of sale, repair or replace any part of the equipment proven defective. This warranty applies only when the equipment is installed, operated and maintained in accordance with Graco's written recommendations.

This warranty does not cover, and Graco shall not be liable for, any malfunction, damage or wear caused by faulty installation, misapplication, abrasion, corrosion, inadequate or improper maintenance, negligence, accident, tampering, or substitution of non-Graco component parts. Nor shall Graco be liable for malfunction, damage or wear caused by the incompatibility with Graco equipment of structures, accessories, equipment or materials not supplied by Graco, or the improper design, manufacture, installation, operation or maintenance of structures, accessories, equipment or materials not supplied by Graco.

This warranty is conditioned upon the prepaid return of the equipment claimed to be defective to an authorized Graco distributor for verification of the claim. If the claimed defect is verified, Graco will repair or replace free of charge any defective parts. The equipment will be returned to the original purchaser transportation prepaid. If inspection of the equipment does not disclose any defect in material or workmanship, repairs will be made at a reasonable charge, which charges may include the costs of parts, labor and transportation.

### DISCLAIMERS AND LIMITATIONS

THE TERMS OF THIS WARRANTY CONSTITUTE PURCHASER'S SOLE AND EXCLUSIVE REMEDY AND ARE IN LIEU OF ANY OTHER WARRANTIES (EXPRESS OR IMPLIED), INCLUDING WARRANTY OF MERCHANTABILITY OR WARRANTY OF FITNESS FOR A PARTICULAR PURPOSE, AND OF ANY NON-CONTRACTUAL LIABILITIES, INCLUDING PRODUCT LIABILITIES, BASED ON NEGLIGENCE OR STRICT LIABILITY. EVERY FORM OF LIABILITY FOR DIRECT, SPECIAL OR CONSEQUENTIAL DAMAGES OR LOSS IS EXPRESSLY EXCLUDED AND DENIED. IN NO CASE SHALL GRACO'S LIABILITY EXCEED THE AMOUNT OF THE PURCHASE PRICE. ANY ACTION FOR BREACH OF WARRANTY MUST BE BROUGHT WITHIN TWO (2) YEARS OF THE DATE OF SALE.

### EQUIPMENT NOT COVERED BY GRACO WARRANTY

GRACO MAKES NO WARRANTY, AND DISCLAIMS ALL IMPLIED WARRANTIES OF MERCHANTABILITY AND FITNESS FOR A PARTICULAR PURPOSE, WITH RESPECT TO ACCESSORIES, EQUIPMENT, MATERIALS, OR COMPONENTS SOLD BUT NOT MANUFACTURED BY GRACO. These items sold, but not manufactured by Graco (such as electric motor, switches, hose, etc.) are subject to the warranty, if any, of their manufacturer. Graco will provide purchaser with reasonable assistance in making any claim for breach of these warranties.

**Graco Headquarters:** Minneapolis  
**International Offices:** Belgium, China, Japan, Korea  
 www.graco.com  
 GRACO INC. P.O. BOX 1441 MINNEAPOLIS, MN 55440-1441  
 PRINTED IN USA 307755F 6/1985 Rev. 08/2009