

## Gun Air Regulator Kit

Part Number 235-042

100 psi (7 bar) Maximum Working Pressure

For use on 2, 5, 10 and 15 gallon stainless steel Pressure Tanks, model no. 236-143 through 236-158, to supply atomizing air to a spray gun from the pressure tank.

## Installation

General (See Fig. 1)

The kit includes the following parts:

Ref. No.	Part No.	Description	Qty.
1	104-267	REGULATOR, air; 2-125 psi	1
2	160-430	GAUGE, air pressure; 0-100 psi	1
3	208-390	VALVE, ball; 1/4 npt(m) x 1/4 npt(m)	1
4	100-206	ADAPTER; 1/2 npt(m) x 1/4 npt(f)	1
5	159-239	NIPPLE, reducing; 1/2 to 3/8 npt	1
6	100-721	PLUG, socket hd; 1/4 npt	1
7	155-665	ADAPTER, union, str swivel; 3/8-3/8	1

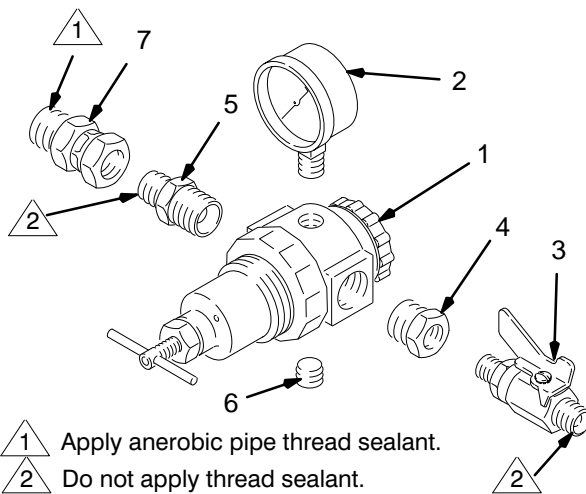

Fig. 1

### WARNING

Always follow the **Pressure Relief Procedure** before opening a pressurized tank cover or fill port. This reduces the risk of serious injury, including splashing in the eyes or on the skin, or injury from moving parts.

### Pressure Relief Procedure

Pressure tanks remain pressurized until pressure is manually relieved. Always relieve pressure in the tank before checking or servicing any part of the spray system; before loosening or removing the pressure tank cover or fill port; and whenever you stop spraying. Refer to Fig. 2.

1. Shut off the air supply to the tank by closing the air inlet valve (9).
2. Open the drain cock fitting (10) by turning it counterclockwise.
3. Wait until no air is escaping through the drain cock fitting before removing the cover or opening the fill port.
4. Leave the drain cock fitting (10) open until you have reinstalled the cover or fill port.

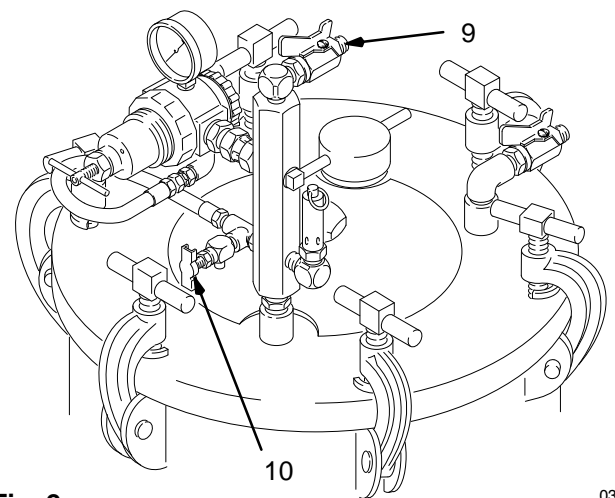

Fig. 2

03359

## Installing the High Pressure Regulator Kit

1. Follow the **Pressure Relief Procedure**.
2. Remove the air inlet manifold pipe plug (11).
3. See Fig. 1. Apply anerobic pipe thread sealant to the male threads of the adapter (7) and install into the manifold (A).
4. Connect the regulator assembly (B) to the swivel nut of the adapter (7).
5. Connect gun air hose to 1/4 npt(m) ball valve (3).

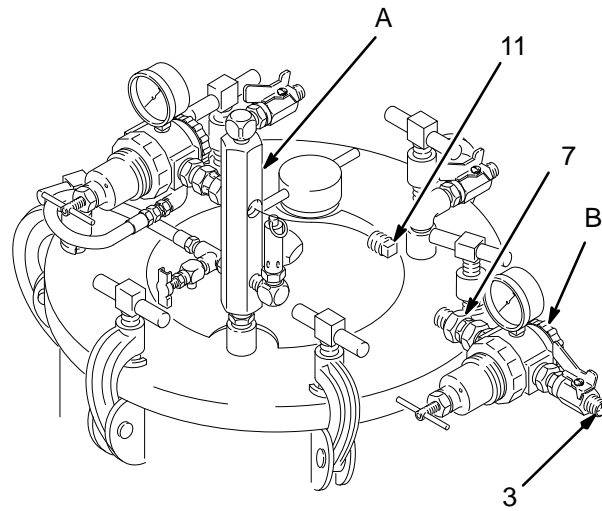

Fig. 3

# The Graco Warranty and Disclaimers

## WARRANTY

Graco warrants all equipment manufactured by it and bearing its name to be free from defects in material and workmanship on the date of sale by an authorized Graco distributor to the original purchaser for use. As purchaser's sole remedy for breach of this warranty, Graco will, for a period of twelve months from the date of sale, repair or replace any part of the equipment proven defective. This warranty applies only when the equipment is installed, operated and maintained in accordance with Graco's written recommendations.

This warranty does not cover, and Graco shall not be liable for, any malfunction, damage or wear caused by faulty installation, misapplication, abrasion, corrosion, inadequate or improper maintenance, negligence, accident, tampering, or substitution of non-Graco component parts. Nor shall Graco be liable for malfunction, damage or wear caused by the incompatibility with Graco equipment of structures, accessories, equipment or materials not supplied by Graco, or the improper design, manufacture, installation, operation or maintenance of structures, accessories, equipment or materials not supplied by Graco.

This warranty is conditioned upon the prepaid return of the equipment claimed to be defective to an authorized Graco distributor for verification of the claim. If the claimed defect is verified, Graco will repair or replace free of charge any defective parts. The equipment will be returned to the original purchaser transportation prepaid. If inspection of the equipment does not disclose any defect in material or workmanship, repairs will be made at a reasonable charge, which charges may include the costs of parts, labor and transportation.

## DISCLAIMERS AND LIMITATIONS

The terms of this warranty constitute purchaser's sole and exclusive remedy and are in lieu of any other warranties (express or implied), **including warranty of merchantability or warranty of fitness for a particular purpose**, and of any non-contractual liabilities, including product liabilities, based on negligence or strict liability. Every form of liability for direct, special or consequential damages or loss is expressly excluded and denied. In no case shall Graco's liability exceed the amount of the purchase price. Any action for breach of warranty must be brought within two (2) years of the date of sale.

## EQUIPMENT NOT COVERED BY GRACO WARRANTY

Graco makes no warranty, and disclaims all implied **warranties of merchantability and fitness for a particular purpose**, with respect to accessories, equipment, materials, or components sold but not manufactured by Graco. These items sold, but not manufactured by Graco (such as electric motor, switches, hose, etc.) are subject to the warranty, if any, of their manufacturer. Graco will provide purchaser with reasonable assistance in making any claim for breach of these warranties.

**Sales Offices:** Atlanta, Chicago, Dallas, Detroit, Los Angeles, Mt. Arlington (N.J.)  
**Foreign Offices:** Canada; England; Korea; Switzerland; France; Germany; Hong Kong; Japan

**GRACO INC. P.O. BOX 1441 MINNEAPOLIS, MN 55440-1441**

PRINTED IN U.S.A. 308-374 3/94