

# 248123/256397 3 Phase to 1 Phase Kit

309961B

**To convert Electric Reactor™, H-25 and H-XP2 Reactor Proportioners from 230V 3 phase to 230V 1 phase**



## Important Safety Instructions

Read all warnings and instructions in this manual.  
Save these instructions.

### WARNING



Installing this kit requires access to parts which may cause electric shock or other serious injury if work is not performed properly. Read warnings in Reactor Repair manual. Be sure to shut off all power to the equipment before repairing.

## Disassembly

1. Turn main power OFF . Disconnect power supply.

### WARNING



Wait 5 minutes for stored voltage to discharge (E-30 and E-XP2 models only).

2. Open Reactor cabinet.
3. See FIG. 1 on page 2. Using 5/32 or 4 mm hex allen wrench, disconnect wire harness (L1, L2, L3) from disconnect switch (A). Do not disconnect the main power leads.
4. Disconnect wire harness ground wire (G) from ground terminal (B).

Disassembly

5. Using a flat blade screw driver, disconnect other end of L1, L2, L3 wires from connectors (C, D, P) at circuit breaker module (E). Disconnect other end of ground wire (G) from ground terminal (F) at right of circuit breaker module.
6. Disconnect first pair of jumper wires (L2, L3) from Transformer Primary 20A circuit breaker (R). Disconnect second pair of jumper wires (L2, L3) from terminal block (H) at left of circuit breaker module (E).
7. Cut wire ties holding wire harness to cabinet walls and remove wire harness from cabinet.
8. Unplug connectors (C, D, P) from buss bar (M). Keep connectors for reuse.
9. Unplug 3 phase buss bar (M) from circuit breaker module (E).

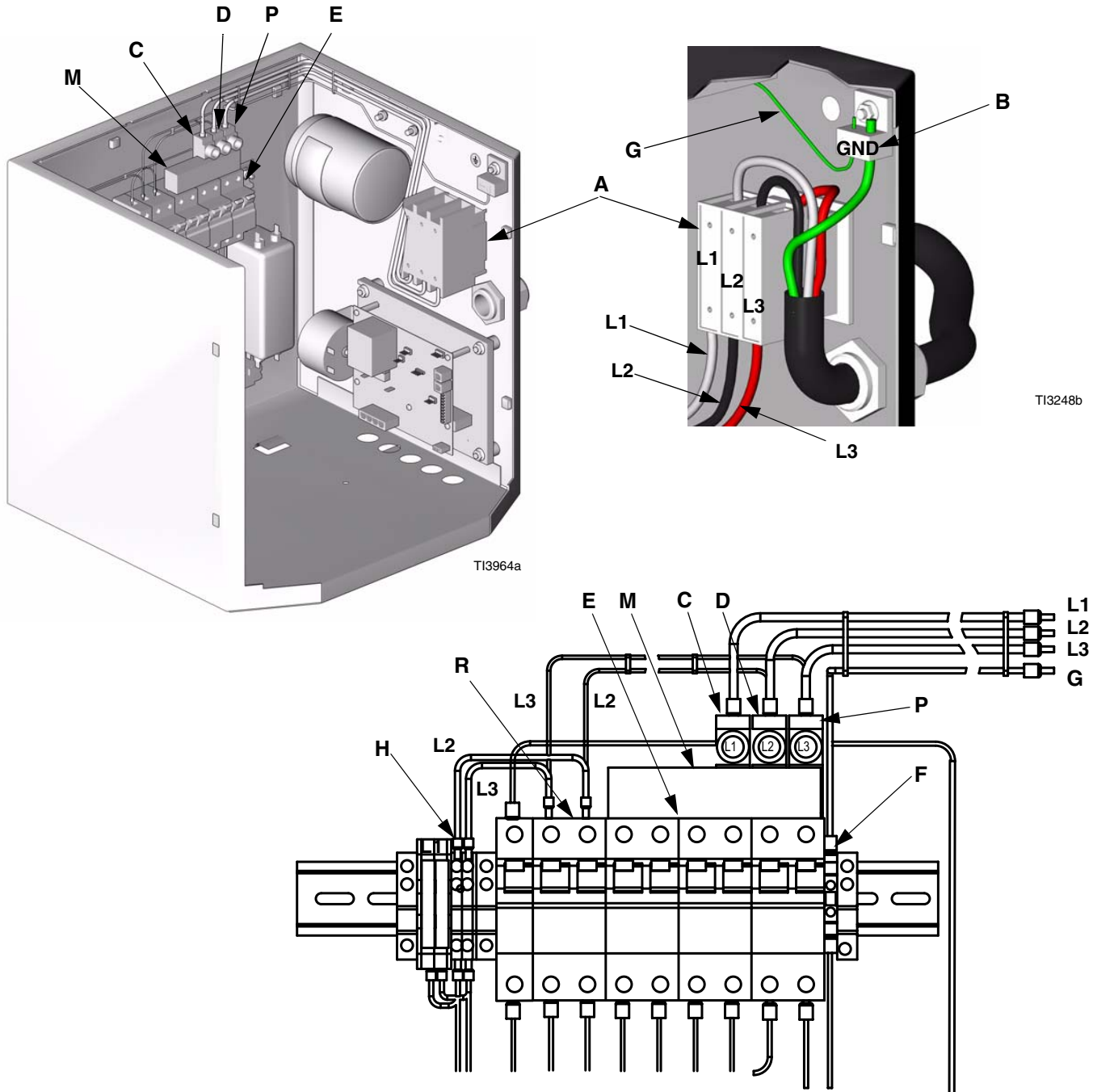
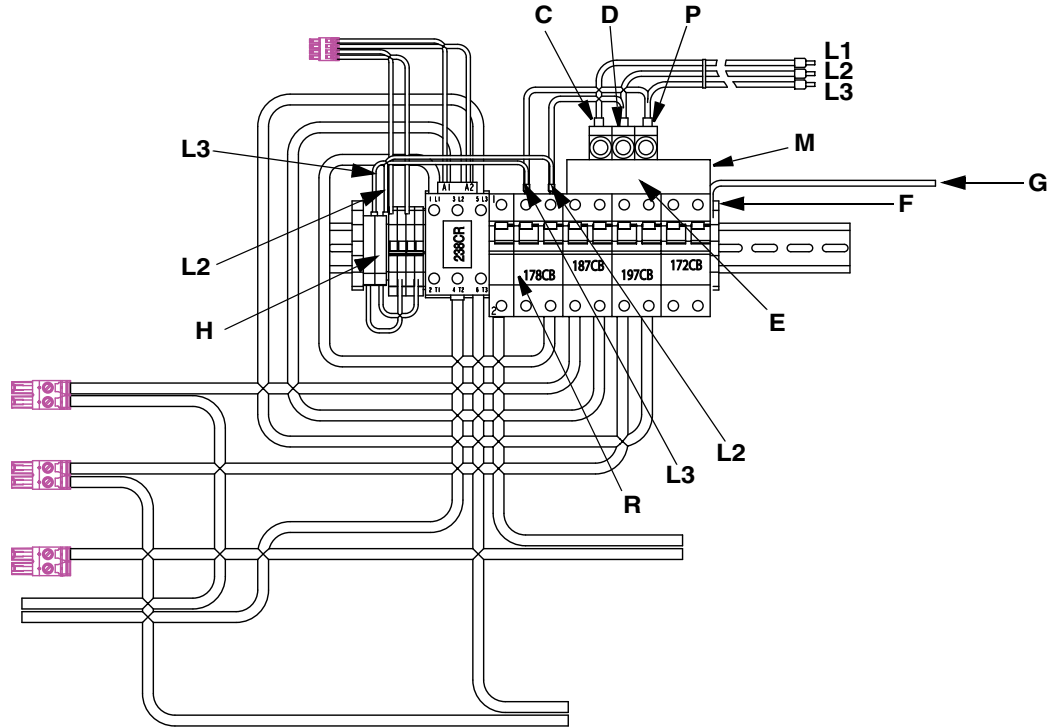

FIG. 1. Kit 248123 for Electric Reactors - Remove 3 Phase Hardware and Wire Harness



**FIG. 2. Kit 256397 for Upgraded Electric Reactors, H-25 and H-XP2 Reactors**

## Installation

1. See FIG. 4 on page 5. Plug 1 phase buss bar (K) into circuit breaker module (E).
2. Plug connectors (C, D) retained from disassembly into buss bar (K) as shown.
3. Using a flat blade screw driver, connect wire harness (L1, L2) to connectors (C, D). Connect wire harness ground wire (G) to ground terminal (F) at right of circuit breaker module (E).
4. Connect jumper wires (L1, L2) to terminal block (H) at left of circuit breaker module (E).
5. Using 5/32 or 4 mm hex allen wrench, connect wire harness (L1, L2) to disconnect switch (A).
6. Route wire harness ground wire (G) over top of disconnect switch (A) and connect to ground terminal (B).
7. Secure wire harness to cabinet walls with wire ties supplied.
8. Close Reactor cabinet.
9. Reconnect power supply. Turn main power ON

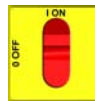

. Return Reactor to service.

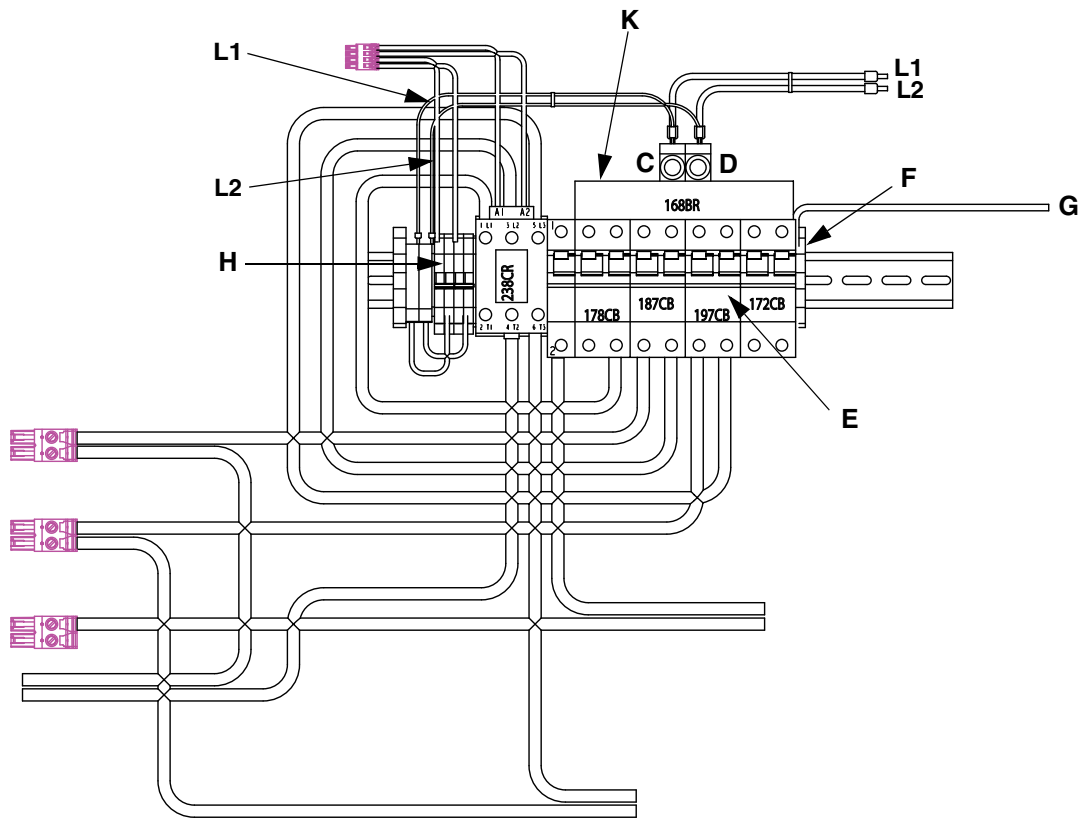

**FIG. 3. Kit 25637 Upgrade Electric Reactors, H-25 and H-XP2 Reactors**

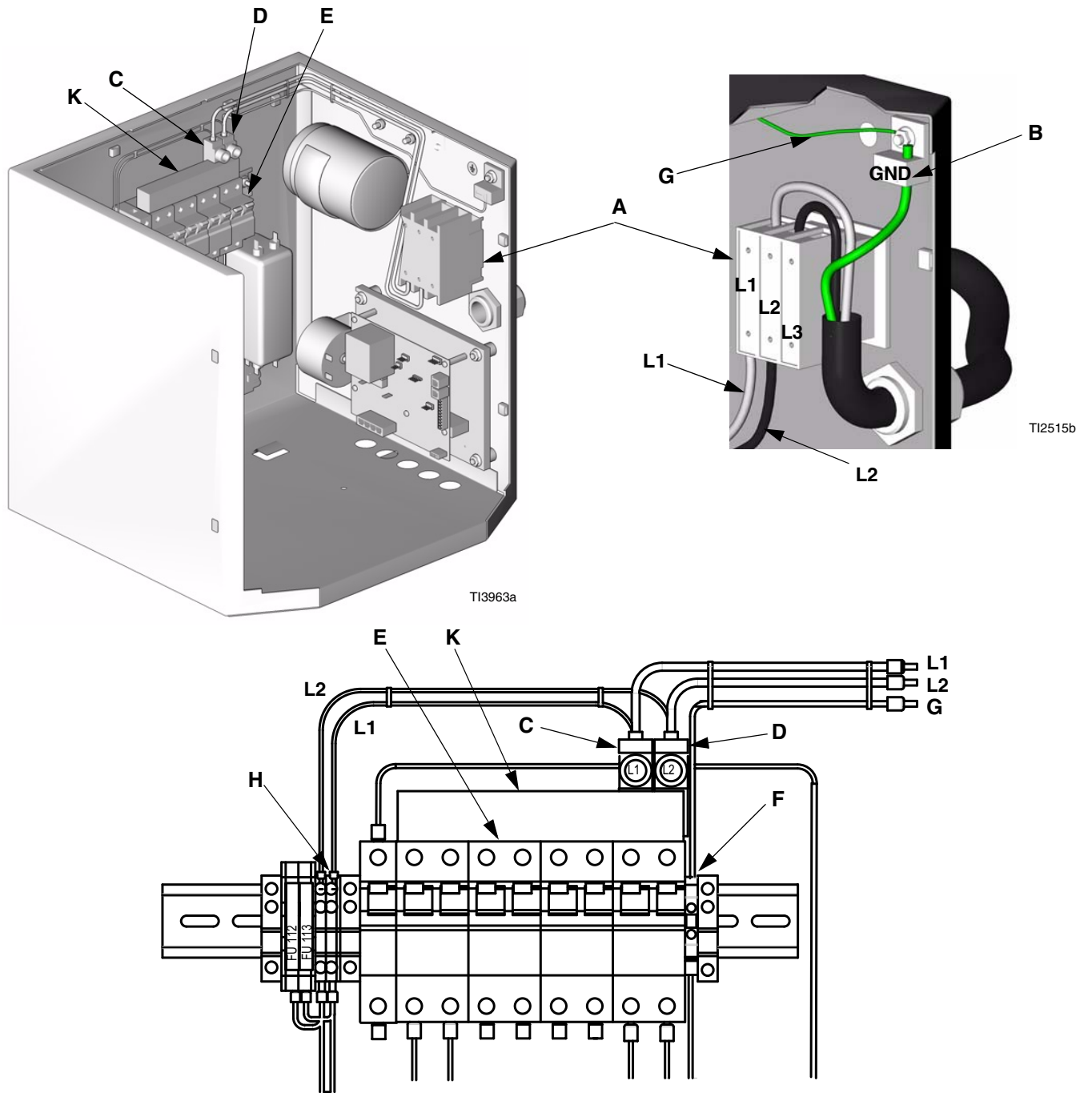

FIG. 4. Kit 248123 for Electric Reactors - Install 1 Phase Wire Harness and Hardware

