

GH™ 833 Sprayers

311484M
EN



IMPORTANT SAFETY INSTRUCTIONS

Read all warnings and instructions in this manual and related manuals.
Be familiar with the controls and the proper usage of the equipment.
Save these instructions.

Models: 249318, 249617, 253471, 253472, 16U287, 16U288, 16V258, 16V260

Maximum Working Pressure 4000 psi (27.6 MPa, 276 bar)

Related Manuals



311279



311283



311485



311254

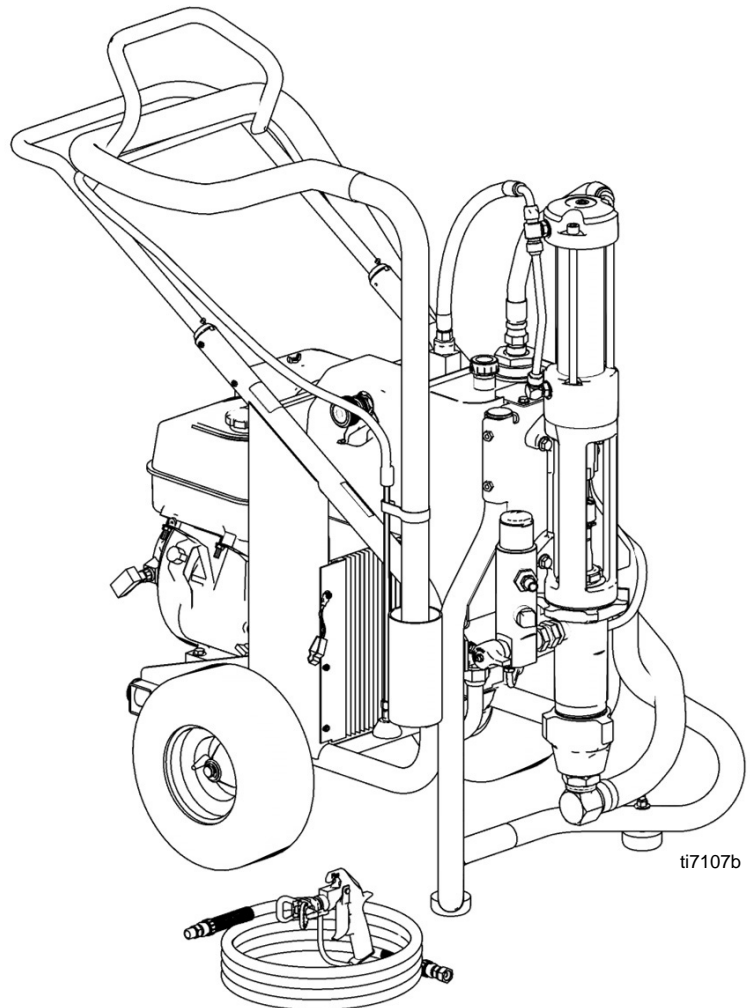

ti7107b



Parts - Frame

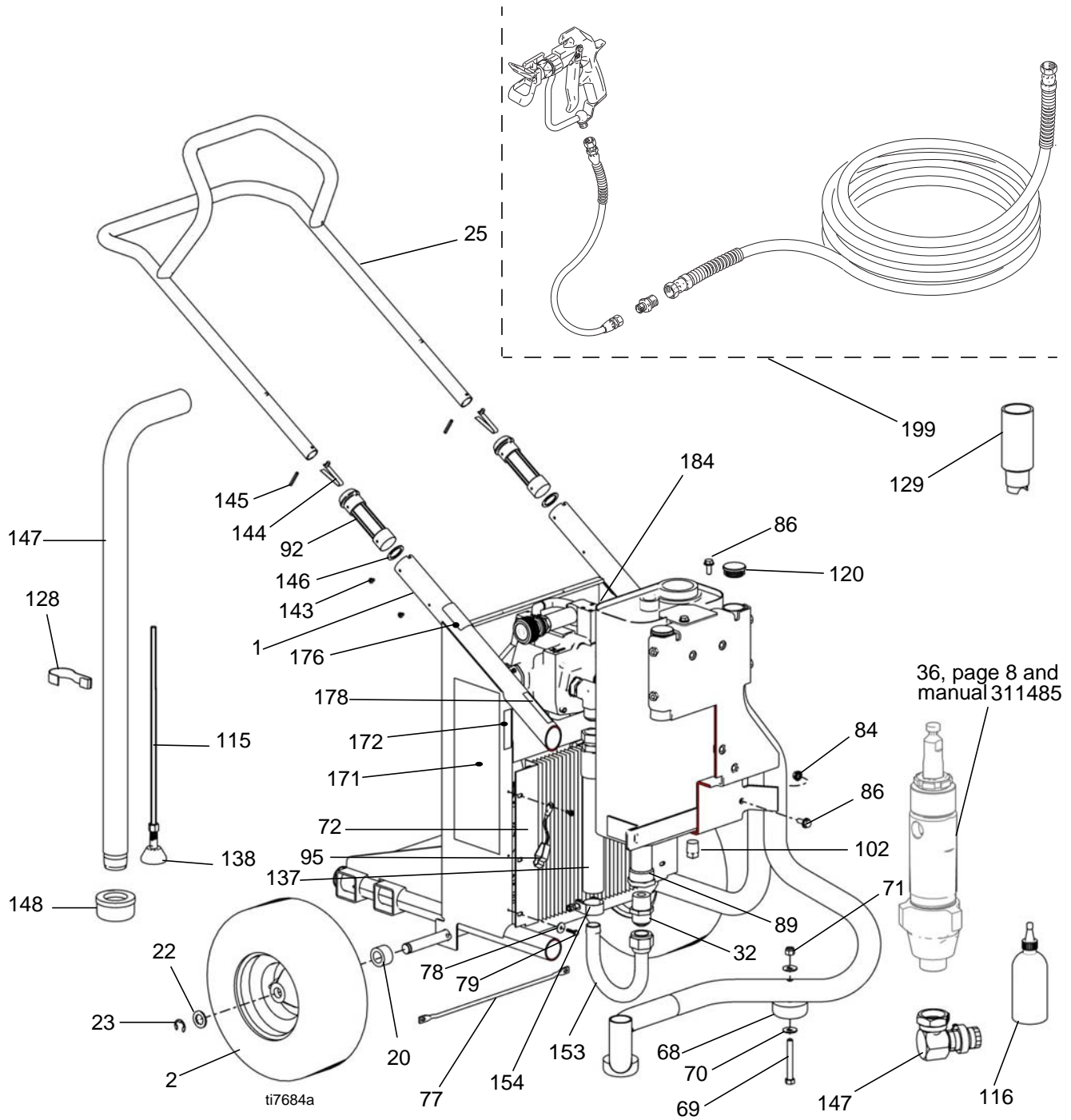

Parts List - Frame

Ref.	Part	Description	Qty	Ref.	Part	Description	Qty
1	15G839	FRAME, GH833, painted	1	137	15G813	HOSE, coupled	1
2	119509	WHEEL, pneumatic	2	138	241920	DEFLECTOR, threaded	1
20	15G547	SPACER, axel	2	143	109032	SCREW, mach, pnh	4
22	154628	WASHER	2	144	112827	BUTTON, snap	2
23	120211	RING, retaining, e-ring	2	145	108068	PIN, spring straight	2
25	287797	KIT, handle, includes 92, 143, 144, 145, 146	1	146	116891	WASHER	2
32	120068	FITTING, hydraulic	1	147		KIT, suction hose, includes 148	1
68	801504	FOOT, rubber	2	147a	287916	standard, non-slvst res	1
69	100454	SCREW, cap hex hd	2	147b	287915	slvt rest, optional	1
70	100132	WASHER, flat	4	147c	287936	2-inch, non-slvst	1
71	101566	NUT, lock	2	148	237840	STRAINER	1
72	287925	COOLER, oil	1	153	15G541	TUBE, J suction	1
77	15H480	BAR, support	1	154	101818	CLAMP, hose	1
78	120339	WASHER, fender	4	171	15G879	LABEL, side, GH833	2
79	C20474	SCREW, self taping	6	166	222385	TAG, warning	1
84	110996	NUT, hex, flanged	2	▲172	15G906	LABEL, lift here	2
86	110963	SCREW, cap, flng hd	4	▲178	194317	LABEL, danger, English	1
89	120137	FILTER, suction	1	▲184	15F146	LABEL set	1
92	15G797	SLEEVE, handle, included in 25	2	199		KIT, gun and hose	1
95	237686	WIRE, ground assembly w/clam	1	❖199a	287850	silver, optional	1
102	124489	PLUG, pipe	1	199b	287851	flex, optional	1
115	245440	KIT, hose drain, includes 138	1	199c	287852	texture, hd, optional	1
116	206994	TSL, 8-oz	1				
120	120314	PLUG, tube	2				
128	198542	CLIP, spring	1				
129	287796	KIT, suction tube, includes 148	1				

▲ Replacement Danger and Warning labels, tags, and cards are available at no cost.

❖ Available with models 249617 and 253472 only.

Parts - Engine and Hoses

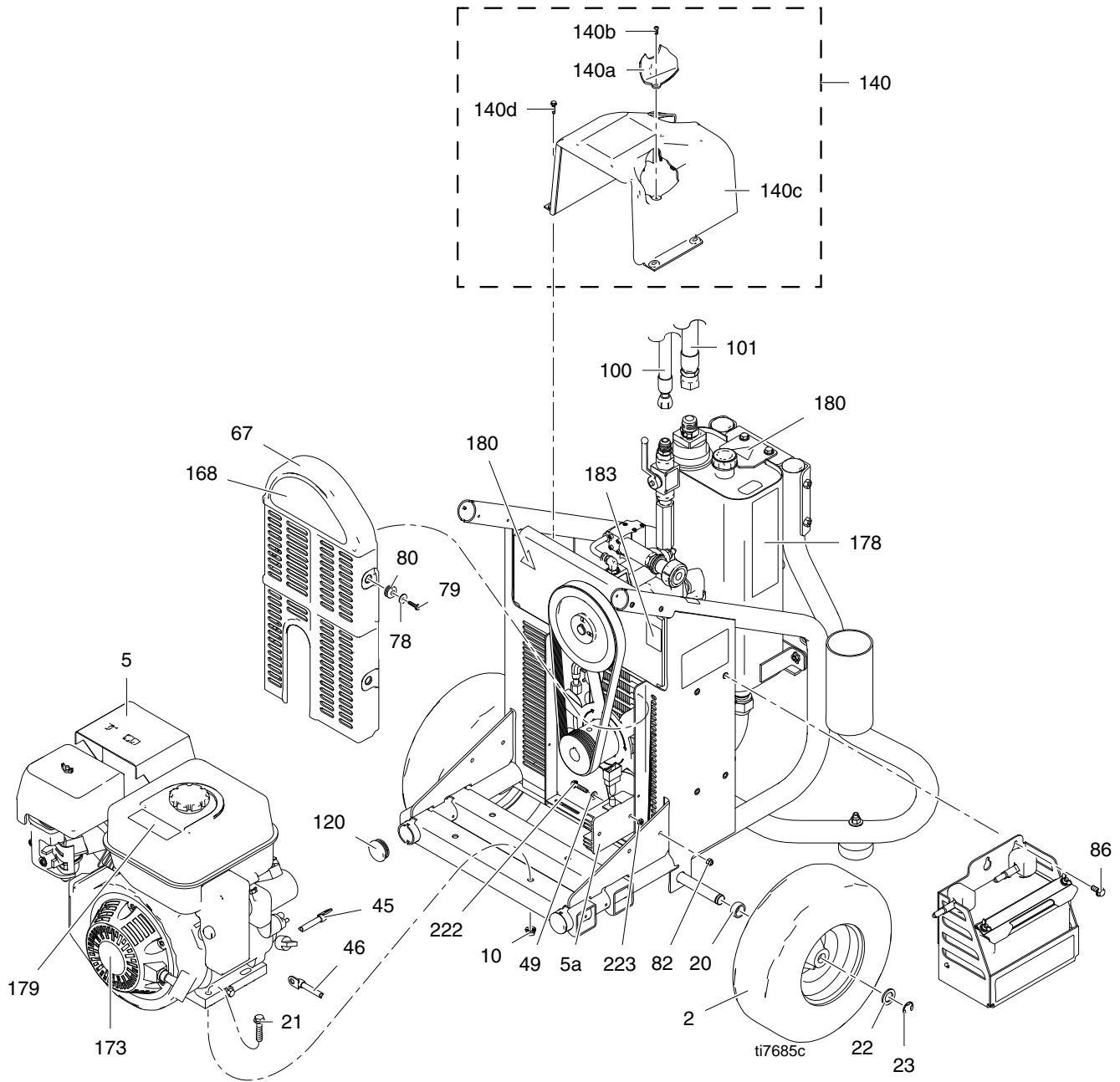

Parts List - Engine and Hoses

Ref.	Part	Description	Qty	Ref.	Part	Description	Qty
2	119509	WHEEL, pneumatic	2	101	15G783	HOSE, coupled	1
75	114703	ENGINE, gas, 13 hp, Honda	1	120	120314	PLUG, tube	4
	16U399	ENGINE, gas, 13 hp, Honda, electric start	1	140	288098	KIT, cover, pump, includes 79	1
75a		VOLTAGE REGULATOR (see Honda manual)	1	140a		COVER, pump, knob	1
10	112958	NUT	1	140b		SCREW, hi/lo, phlps, pwhd	1
20	15G547	SPACER, axle	2	140c		COVER, hydr pump	1
21	116780	SCREW, hex hd, flanged	4	140d		SCREW, self tapping	4
22	154628	WASHER	2	168	15G876	LABEL, back, GH833	1
23	120211	RING, retaining, e-ring	2	7171	16U578	LABEL, side, top, GH833	1
745	113951	CABLE, electric, neg	1	173	15G907	LABEL, Honda GX390 13 hp	1
746	107073	CABLE, electric, positive	1	▲178	15D523	LABEL, warning, EN/FR/ES	1
749	110755	WASHER	2	▲179	194126	LABEL, warning	1
67	288099	KIT, cover, pulley fan, includes 78, 79, 80	1	▲180	189285	LABEL, caution	1
78	120339	WASHER, fender	4	▲183	198492	LABEL, warning	1
80	120415	GROMMET	4	7222	120444	SCREW	2
782	102040	WASHER, lock	2	7223	101345	NUT	2
786	110963	SCREW, cap, flange head	12				
100	15G781	HOSE, coupled	1				

▲ Replacement Danger and Warning labels, tags, and cards are available at no cost.

† Used on models 16U287, 16U288, 16V258, 16V260 only.

Parts - Engine, Hydraulic Pump & Reservoir

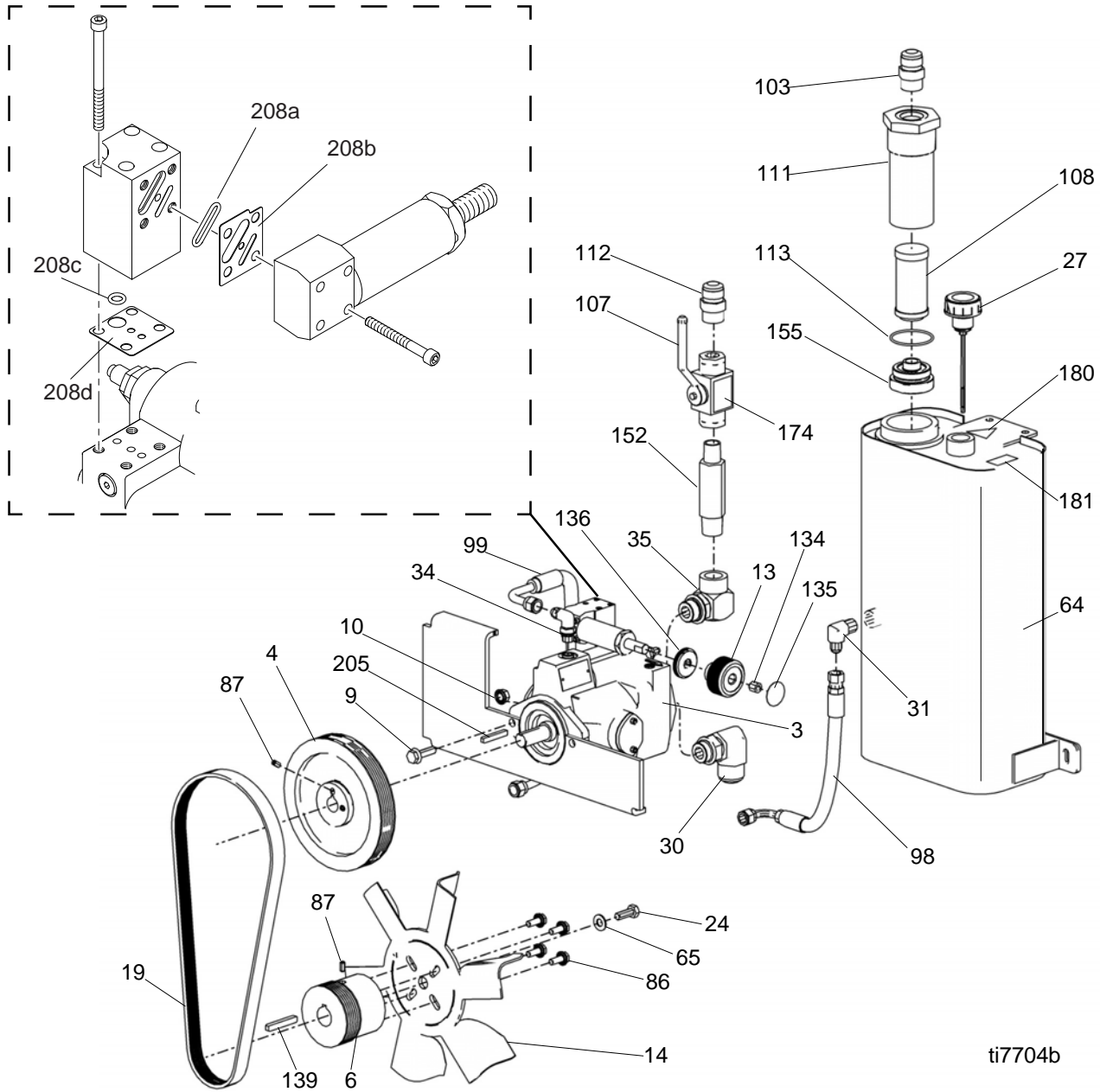

ti7704b

Parts List - Engine, Hydraulic Pump & Reservoir

Ref.	Part	Description	Qty	Ref.	Part	Description	Qty
3	288105	KIT, pump, hydraulic, includes 9, 10, 13, 134, 135, 136	1	108	287871	KIT, hydraulic oil filter, includes 113	1
4	15G812	PULLEY, pump	1	111	15H246	HOUSING, filter	1
6	15G811	PULLEY, drive, engine	1	112	120304	FITTING, nipple	1
9	111193	SCREW, cap, flang hd	2	113	120315	O-RING	1
10	112958	NUT, hex, flanged	2	134	117560	SCREW, set, socket hd	1
13	15B438	KNOB, pressure	1	135	15A464	LABEL, control	1
14	119971	FAN	1	136	15G767	COLLAR, locking, pressure knob	1
19	120172	BELT, poly-V	11	139	801137	KEY, engine pulley	1
24	116596	SCREW, cap, hex, hd	1	152	120175	FITTING, ball valve	1
27	17L161	CAP, breather/fill	1	155	15H247	CAP, filter housing	1
30	120066	FITTING, elbow, hydraulic	1	174	15G908	LABEL, hdry lever ON/OFF	1
31	120064	FITTING, elbow, hydraulic	1	▲180	189285	LABEL, caution	1
34	116793	FITTING, elbow, hydraulic	1	181	198585	LABEL, hydraulic fluid	1
35	120067	FITTING, elbow, hydraulic	1	205	183401	KEY, pump pulley	1
64	15G545	RESERVOIR, painted	1	208	287100	KIT, seal, compensator (includes 208a, 208b, 208c, 208d)	1
65	100731	WASHER	1	208a		O-RING, oval	1
86	110963	SCREW, cap, flng hd	4	208b		GASKET, comp/block	1
87	100002	SCREW, set, sch	3	208c		O-RING	1
98	15G784	HOSE, coupled	1	208d		GASKET, block/cover	1
99	15G782	HOSE, coupled	1				
103	120063	FITTING,	1				
107	120140	VALVE, ball	1				

▲ Replacement Danger and Warning labels, tags, and cards are available at no cost.

Parts - Pump Stackup & Hydraulic Motor

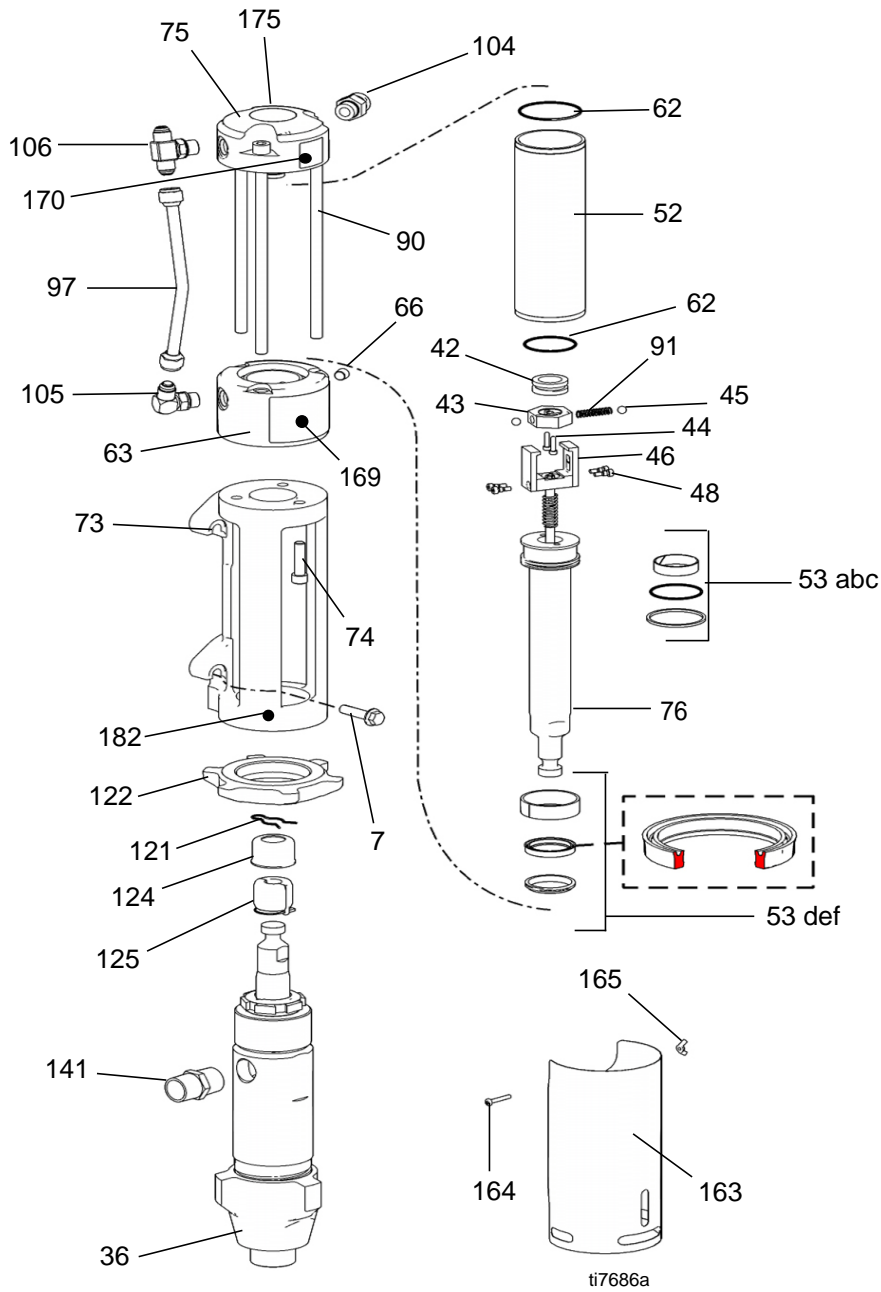

Parts List - Pump Stackup & Hydraulic Motor

Ref.	Part	Description	Qty	Ref.	Part	Description	Qty
7*	120226	SCREW, hex hd, flange	4	90*	120138	SCREW, cap, socket head	3
36	287834	KIT, pump, displacement, includes 141 Manual 311485	1	91†	120146	SPRING, compression	1
42	15G501	SLEEVE, valve, hydr, motor	1	97	287841	TUBE	1
43	15G503	STOP, valve, hydraulic motor	1	104*	120065	FITTING, hydraulic	1
44	15D256	SCREW, cap, sch	2	105*	117607	FITTING, elbow std thd	1
45	101947	BALL, bearing	2	106*	117609	FITTING, tee, branch, str thd	1
46†	15G270	YOKE, arm, hydraulic motor	2	121*	116407	CLIP, hairpin	1
48†	105270	SCREW, shoulder, sch	4	122	15G204	NUT, retaining	1
52*	287869	CYLINDER, hydraulic motor	1	124	197340	COVER, coupler	1
53	287870	KIT, repair, packing, hydraulic, includes 62	1	125*	244819	COUPLING, assembly	1
53a†		BEARING, piston		141	15H335	FITTING, nipple, 1 in. npt,	1
53b†		O-RING, piston		169▲	15G877	LABEL, front	1
53c†		SEAL, piston, hydraulic motor		170▲*	15G878	LABEL, Graco logo	1
53d*		SEAL, rod		175▲*	15B063	LABEL, included with 75	1
53e*		BEARING, rod		163‡	15H201	SHIELD, pump	1
53f*		WIPER, rod		164‡	111235	SCREW, mach, pnh	1
62*	116084	PACKING, o-ring	2	165‡	120317	NUT, wing	1
63*	15G559	HOUSING, hydraulic motor, lower	1	182▲	192840	LABEL, warning	1
66*	101970	PLUG, pipe	1				
73*	15G639	ADAPTER, hydraulic motor/pump	1				
74*	120202	SCREW, cap sch	3				
75†	288061	CAP, hydraulic head, includes 175	1				
76*	287868	PISTON, rod, hydraulic	1				

▲ Replacement Danger and Warning labels, tags, and cards are available at no cost.

‡ Use on models 253471, 253472, 16V258, and 16V260 only.

* Included in Hydraulic Motor Kit 24Y566

† Included in Piston Rod Hydraulic Kit 287868

Parts - Filter

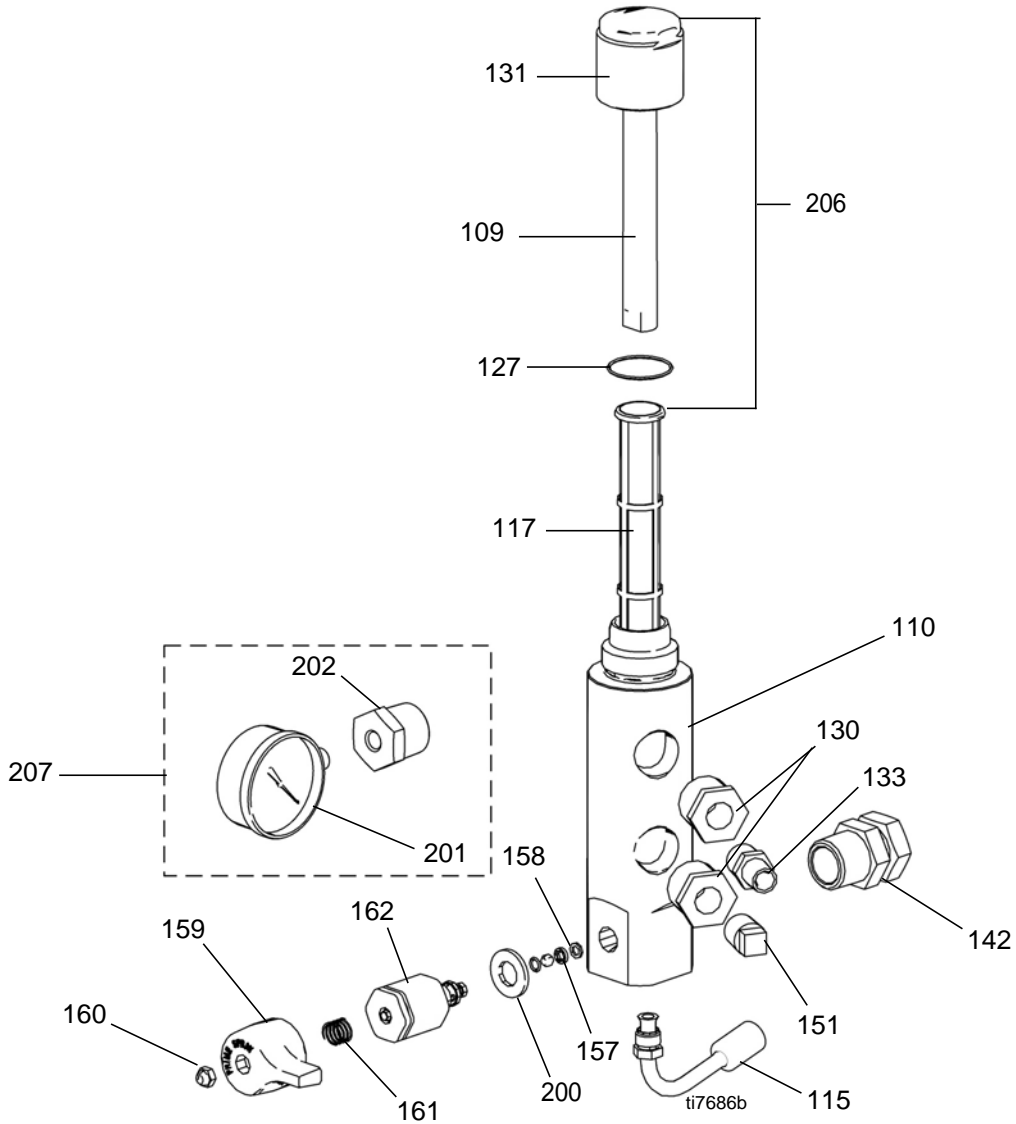

Parts List - Filter

Ref.	Part	Description	Qty	Ref.	Part	Description	Qty
109	15C766	TUBE, diffusion	1	160	116424	NUT, cap	1
110	15G649	BASE, filter	1	161	114708	SPRING, compression	1
115	245440	KIT, hose, drain	1	162	245103	KIT, valve, drain, includes 157, 158, 159, 160, 161, 162, 200	1
117	244067	FILTER, fluid	1	200	114797	GASKET	1
127	117285	PACKING, o-ring	1	201	102814	GAUGE	1
130	124488	BUSHING, pipe	2	202	119969	FITTING, reducer	1
131	15C765	CAP, filter	1	206	287285	KIT, cap filter, includes 109, 127, 131	1
133	16F255	FITTING, nipple, rdcg	1	‡207	288097	KIT, gauge kit, includes 201, 202	1
142	287968	FITTING, union, adapter	1				
151	124489	PLUG, pipe	1				
157	193709	SEAT, valve	1				
158	193710	SEAL, seat, valve	1				
159	15G563	HANDLE, valve	1				

‡ Use on models 253471 and 253472 only.

Battery

(Models 16U287, 16U288, 16V258, and 16V260 Only)

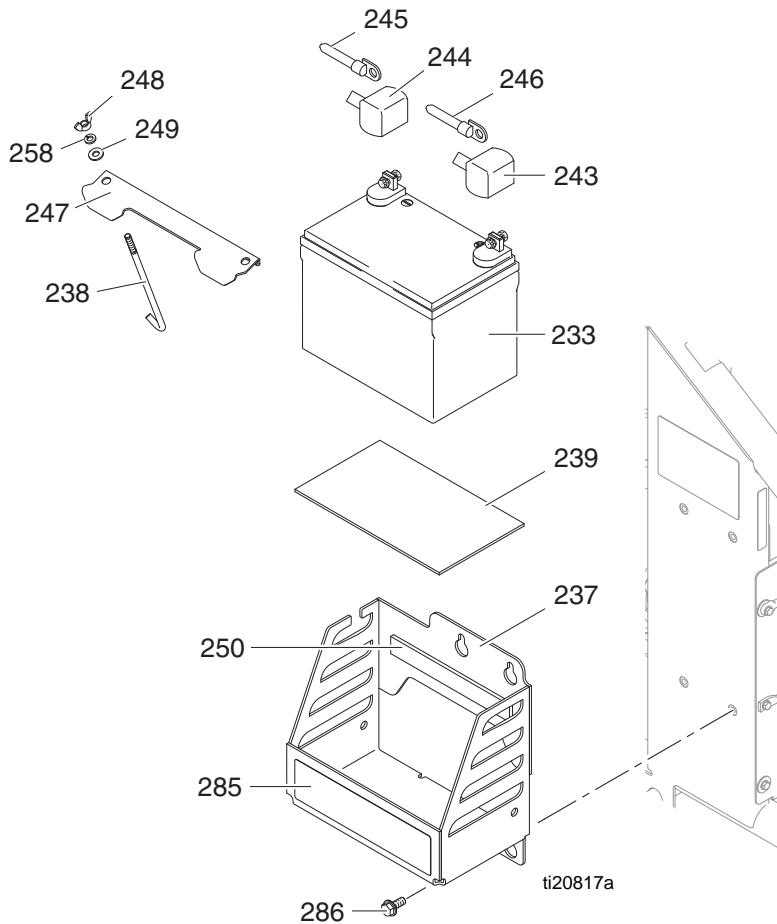

Parts List

Ref.	Part	Description	Qty	Ref.	Part	Description	Qty
233	115753	BATTERY, 33 AH, sealed	1	247	107069	CLAMP, battery	1
237	16U412	TRAY, battery, gh-es, painted	1	248	100011	NUT, wing	2
238	107068	HOOK, bolt	2	249	110755	WASHER, plain	2
239	801972	PAD, battery	1	250	15F366	PAD, foam	1
243	801958	PROTECTOR, terminal, red	1	258	100016	WASHER, lock	2
244	801959	TERMINAL, protector, black	1	285	16U559	LABEL, brand, es, side	1
245	113951	CABLE, electric, neg (black)	1	286	110963	SCREW, cap, flange head	12
246	107073	CABLE, electric, positive (red)	1				

Graco Standard Warranty

Graco warrants all equipment referenced in this document which is manufactured by Graco and bearing its name to be free from defects in material and workmanship on the date of sale to the original purchaser for use. With the exception of any special, extended, or limited warranty published by Graco, Graco will, for a period of twelve months from the date of sale, repair or replace any part of the equipment determined by Graco to be defective. This warranty applies only when the equipment is installed, operated and maintained in accordance with Graco's written recommendations.

This warranty does not cover, and Graco shall not be liable for general wear and tear, or any malfunction, damage or wear caused by faulty installation, misapplication, abrasion, corrosion, inadequate or improper maintenance, negligence, accident, tampering, or substitution of non-Graco component parts. Nor shall Graco be liable for malfunction, damage or wear caused by the incompatibility of Graco equipment with structures, accessories, equipment or materials not supplied by Graco, or the improper design, manufacture, installation, operation or maintenance of structures, accessories, equipment or materials not supplied by Graco.

This warranty is conditioned upon the prepaid return of the equipment claimed to be defective to an authorized Graco distributor for verification of the claimed defect. If the claimed defect is verified, Graco will repair or replace free of charge any defective parts. The equipment will be returned to the original purchaser transportation prepaid. If inspection of the equipment does not disclose any defect in material or workmanship, repairs will be made at a reasonable charge, which charges may include the costs of parts, labor, and transportation.

THIS WARRANTY IS EXCLUSIVE, AND IS IN LIEU OF ANY OTHER WARRANTIES, EXPRESS OR IMPLIED, INCLUDING BUT NOT LIMITED TO WARRANTY OF MERCHANTABILITY OR WARRANTY OF FITNESS FOR A PARTICULAR PURPOSE.

Graco's sole obligation and buyer's sole remedy for any breach of warranty shall be as set forth above. The buyer agrees that no other remedy (including, but not limited to, incidental or consequential damages for lost profits, lost sales, injury to person or property, or any other incidental or consequential loss) shall be available. Any action for breach of warranty must be brought within two (2) years of the date of sale.

GRACO MAKES NO WARRANTY, AND DISCLAIMS ALL IMPLIED WARRANTIES OF MERCHANTABILITY AND FITNESS FOR A PARTICULAR PURPOSE, IN CONNECTION WITH ACCESSORIES, EQUIPMENT, MATERIALS OR COMPONENTS SOLD BUT NOT MANUFACTURED BY GRACO. These items sold, but not manufactured by Graco (such as electric motors, switches, hose, etc.), are subject to the warranty, if any, of their manufacturer. Graco will provide purchaser with reasonable assistance in making any claim for breach of these warranties.

In no event will Graco be liable for indirect, incidental, special or consequential damages resulting from Graco supplying equipment hereunder, or the furnishing, performance, or use of any products or other goods sold hereto, whether due to a breach of contract, breach of warranty, the negligence of Graco, or otherwise.

FOR GRACO CANADA CUSTOMERS

The Parties acknowledge that they have required that the present document, as well as all documents, notices and legal proceedings entered into, given or instituted pursuant hereto or relating directly or indirectly hereto, be drawn up in English. Les parties reconnaissent avoir convenu que la rédaction du présente document sera en Anglais, ainsi que tous documents, avis et procédures judiciaires exécutés, donnés ou intentés, à la suite de ou en rapport, directement ou indirectement, avec les procédures concernées.

Graco Information

For the latest information about Graco products, visit www.graco.com.

For patent information, see www.graco.com/patents.

TO PLACE AN ORDER, contact your Graco distributor or call 1-800-690-2894 to identify the nearest distributor.

All written and visual data contained in this document reflects the latest product information available at the time of publication. Graco reserves the right to make changes at any time without notice.

For patent information, see www.graco.com/patents.
Original instructions. *This manual contains English. MM 311484*

Graco Headquarters: Minneapolis
International Offices: Belgium, China, Japan, Korea

GRACO INC. AND SUBSIDIARIES • P.O. BOX 1441 • MINNEAPOLIS MN 55440-1441 • USA

Copyright 2012, Graco Inc. All Graco manufacturing locations are registered to ISO 9001.

www.graco.com
Revised M, May 2016