

Integrated PowerStation™

3A6335A

EN

For modular generation of electrical power, fluid heat transfer, and compressed air. For use with Reactor 2™ E-30, E-XP2, H-30, and H-XP2 proportioners only. For professional use only.

300 psi (2.1 MPa, 20.7 bar) Maximum Fluid Inlet Pressure



Important Safety Instructions

Read all warnings and instructions in this manual and in the Reactor 2 manual before using this equipment. Save these instructions.

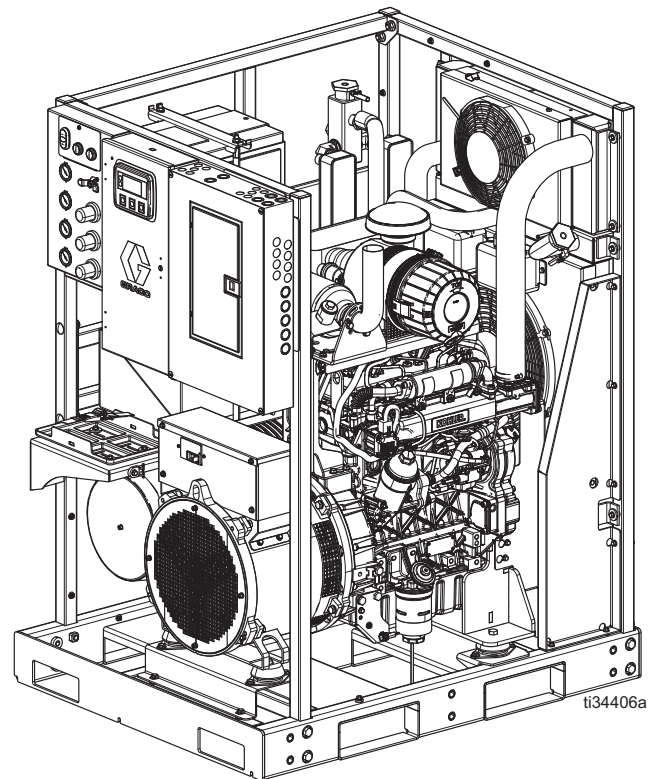

Contents

Related Manuals	2	Installation	18
Supplied Manuals	2	Locate System	18
Models	3	Trailer or Vehicle Setup	18
Accessory Kits	3	Grounding	20
Warnings	4	Connect Battery	20
Important Isocyanate Information	7	Secure Fuel Tank	21
Material Self-ignition	8	Add Fuel	21
Keep Components A and B Separate	8	Install Heat Exchanger Relocation Kit (25B067)	22
Changing Materials	8	Connect Component A and B Hoses	26
Moisture Sensitivity of Isocyanates	8	Connect Air Lines	28
Foam Resins with 245 fa Blowing Agents	8	Electrical Connections	28
Typical Installation	9	Operation	32
Integrated PowerStation	9	First Time Startup	35
With Reactor Pallet, Fuel Tank Pallet, and Fuel Tank Kits	10	Update Reactor 2 Software	36
With Heat Exchanger Relocation Kit	11	Fluid Circulation	37
Component Identification	12	Pressure Relief Procedure	37
Overview	12	Shutdown	38
Compressed Air and Coolant Components ...	13	Immediate Shutdown	38
Coolant Components	14	Daily Shutdown	38
Single-Side Engine Service	15	Technical Specifications	40
Engine Controls Enclosure	16	California Proposition 65	41
Air Controls Panel	17	Graco Extended Warranty	42

Related Manuals

Manual in English	Description
333023	Reactor 2 E-30 and E-XP2 Proportioning Systems (Operation)
334945	Reactor 2 Hydraulic Proportioning Systems (Operation)

Supplied Manuals

Manual Description	Compatible Model
Kohler® Diesel KDI Owner Manual	All models
Mecc Alte® Self-Regulating Alternators Series NPE	All models
Hydrovane® Compressor HV04 (20 cfm)	979201
Hydrovane® Compressor HR07 (35 cfm)	979202
Hankison® Air Dryer HIT20	979201
Hankison® Air Dryer HIT35	979202

Models

Model	979200	979201	979202
Description	Integrated PowerStation, Tier 4 Final, no air	Integrated PowerStation, Tier 4 Final, 20 cfm	Integrated PowerStation, Tier 4 Final, 35 cfm
Engine	Kohler®, KDI1903TCR, 33.6 kWm (continuous)		
Alternator	Mecc Alte®, 240 Vac, 1-phase, 60 Hz, 22 kVA		
Auxiliary Power (at 60 Hz)	9.1 kVA (38 A at 240 Vac)*	8.6 kVA (36 A at 240 Vac)*	
Compressor	Not included	Hydrovane®, HV04, 20 cfm	Hydrovane®, HR07, 35 cfm
Air Dryer	Not included	Hankison®, HIT20, 22 cfm	Hankison®, HIT35, 35 cfm
Air Controls	Not included	✓	✓





* Additional power is available with some configurations. See **Technical Specifications** (page 40) for details.

Accessory Kits

Kit	Part	Description
Fuel Tank Kit	24K390	20 gal. (75.7 L) fuel tank
Fuel Tank Pallet Extension Kit	25E307	Pallet extension to connect the fuel tank to the Integrated PowerStation
Reactor 2 Pallet Extension Kit	25E306	Pallet extension to connect the Reactor 2 proportioner to the Integrated PowerStation
Heat Exchanger Relocation Kit	25B067	Bracket to relocate the heat exchange assembly

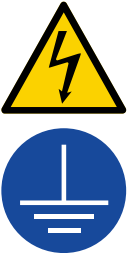







Warnings

The following warnings are for the setup, use, grounding, maintenance, and repair of this equipment. The exclamation point symbol alerts you to a general warning and the hazard symbols refer to procedure-specific risks. When these symbols appear in the body of this manual or on warning labels, refer back to these Warnings. Product-specific hazard symbols and warnings not covered in this section may appear throughout the body of this manual where applicable.

 <h1 style="margin: 0;">WARNING</h1>	
	<p>ELECTRIC SHOCK HAZARD</p> <p>This equipment must be grounded. Improper grounding, setup, or usage of the system can cause electric shock.</p> <ul style="list-style-type: none"> • Turn off and disconnect power at main switch before disconnecting any cables and before servicing or installing equipment. • Connect only to grounded power source. • All electrical wiring must be done by a qualified electrician and comply with all local codes and regulations. • Do not expose to rain. Store indoors.
	<p>ENTANGLEMENT HAZARD</p> <p>Rotating parts can cause serious injury.</p> <ul style="list-style-type: none"> • Keep clear of moving parts. • Do not operate equipment with protective guards or covers removed. • Do not wear loose clothing, jewelry or long hair while operating equipment. • Equipment can start without warning. Before checking, moving, or servicing equipment, follow the Pressure Relief Procedure and disconnect all power sources.
	<p>BURN HAZARD</p> <p>Equipment surfaces and fluid that is heated can become very hot during operation. To avoid severe burns:</p> <ul style="list-style-type: none"> • Do not touch hot fluid or equipment.
	<p>TOXIC FLUID OR FUMES HAZARD</p> <p>Toxic fluids or fumes can cause serious injury or death if splashed in the eyes or on skin, inhaled or swallowed.</p> <ul style="list-style-type: none"> • Read Safety Data Sheets (SDSs) for handling instructions and to know the specific hazards of the fluids you are using, including the effects of long-term exposure. • When spraying, servicing equipment, or when in the work area, always keep work area well-ventilated and always wear appropriate personal protective equipment. See Personal Protective Equipment warnings in this manual. • Store hazardous fluid in approved containers, and dispose of it according to applicable guidelines.
	<p>PERSONAL PROTECTIVE EQUIPMENT</p> <p>Always wear appropriate personal protective equipment and cover all skin when spraying, servicing equipment, or when in the work area. Protective equipment helps prevent serious injury, including long-term exposure; inhalation of toxic fumes, mists or vapors; allergic reaction; burns; eye injury and hearing loss. This protective equipment includes but is not limited to:</p> <ul style="list-style-type: none"> • A properly fitting respirator, which may include a supplied-air respirator, chemically impermeable gloves, protective clothing and foot coverings as recommended by the fluid manufacturer and local regulatory authority. • Protective eyewear and hearing protection.









WARNING

   	<p>FIRE AND EXPLOSION HAZARD</p> <p>Flammable fumes, such as solvent and paint fumes, in work area can ignite or explode. Paint or solvent flowing through the equipment can cause static sparking. To help prevent fire and explosion:</p> <ul style="list-style-type: none"> • Use equipment only in well-ventilated area. • Do not fill fuel tank while engine is running or hot; shut off engine and let it cool. Fuel is flammable and can ignite or explode if spilled on hot surface. • Eliminate all ignition sources; such as pilot lights, cigarettes, portable electric lamps, and plastic drop cloths (potential static sparking). • Ground all equipment in the work area. See Grounding instructions. • Never spray or flush solvent at high pressure. • Keep work area free of debris, including solvent, rags and gasoline. • Do not plug or unplug power cords, or turn power or light switches on or off when flammable fumes are present. • Use only grounded hoses. • Hold gun firmly to side of grounded pail when triggering into pail. Do not use pail liners unless they are anti-static or conductive. • Stop operation immediately if static sparking occurs or you feel a shock. Do not use equipment until you identify and correct the problem. • Keep a working fire extinguisher in the work area.
 	<p>BATTERY HAZARD</p> <p>Lead-acid batteries produce explosive gases and contain sulfuric acid that can cause severe burns. To avoid sparks and injury when handling or working with a lead-acid battery:</p> <ul style="list-style-type: none"> • Read and follow the battery manufacturer's warnings. • Exercise caution when working with metallic tools or conductors to prevent short circuits and sparks. • Keep all sparks, flames, and cigarettes away from batteries. • Always wear protective eyewear and protective equipment for face, hands, and body. • If you have direct contact with battery fluid, flush with water and consult a physician immediately. • Installation and maintenance must be performed by knowledgeable personnel only.
  	<p>THERMAL EXPANSION HAZARD</p> <p>Fluids subjected to heat in confined spaces, including hoses, can create a rapid rise in pressure due to the thermal expansion. Over-pressurization can result in equipment rupture and serious injury.</p> <ul style="list-style-type: none"> • Open a valve to relieve the fluid expansion during heating. • Replace hoses proactively at regular intervals based on your operating conditions.



WARNING

 	<p>EQUIPMENT MISUSE HAZARD</p> <p>Misuse can cause death or serious injury.</p> <ul style="list-style-type: none"> • Do not operate the unit when fatigued or under the influence of drugs or alcohol. • Do not exceed the maximum working pressure or temperature rating of the lowest rated system component. See Technical Specifications in all equipment manuals. • Use fluids and solvents that are compatible with equipment wetted parts. See Technical Specifications in all equipment manuals. Read fluid and solvent manufacturer's warnings. For complete information about your material, request Safety Data Sheets (SDSs) from distributor or retailer. • Do not leave the work area while equipment is energized or under pressure. • Turn off all equipment and follow the Pressure Relief Procedure when equipment is not in use. • Check equipment daily. Repair or replace worn or damaged parts immediately with genuine manufacturer's replacement parts only. • Do not alter or modify equipment. Alterations or modifications may void agency approvals and create safety hazards. • Make sure all equipment is rated and approved for the environment in which you are using it. • Use equipment only for its intended purpose. Call your distributor for information. • Route hoses and cables away from traffic areas, sharp edges, moving parts, and hot surfaces. • Do not kink or over bend hoses or use hoses to pull equipment. • Keep children and animals away from work area. • Comply with all applicable safety regulations.
  	<p>PRESSURIZED EQUIPMENT HAZARD</p> <p>Fluid from the equipment, leaks, or ruptured components can splash in the eyes or on skin and cause serious injury.</p> <ul style="list-style-type: none"> • Follow the Pressure Relief Procedure when you stop spraying/dispersing and before cleaning, checking, or servicing equipment. • Tighten all fluid connections before operating the equipment. • Check hoses, tubes, and couplings daily. Replace worn or damaged parts immediately.
	<p>PRESSURIZED ALUMINUM PARTS HAZARD</p> <p>Use of fluids that are incompatible with aluminum in pressurized equipment can cause serious chemical reaction and equipment rupture. Failure to follow this warning can result in death, serious injury, or property damage.</p> <ul style="list-style-type: none"> • Do not use 1,1,1-trichloroethane, methylene chloride, other halogenated hydrocarbon solvents or fluids containing such solvents. • Do not use chlorine bleach. • Many other fluids may contain chemicals that can react with aluminum. Contact your material supplier for compatibility.
	<p>CARBON MONOXIDE HAZARD</p> <p>Exhaust contains poisonous carbon monoxide, which is colorless and odorless. Breathing carbon monoxide can cause death.</p> <ul style="list-style-type: none"> • Do not operate in an enclosed area.

Important Isocyanate Information

Isocyanates (ISO) are catalysts used in two component materials.

Isocyanate Conditions

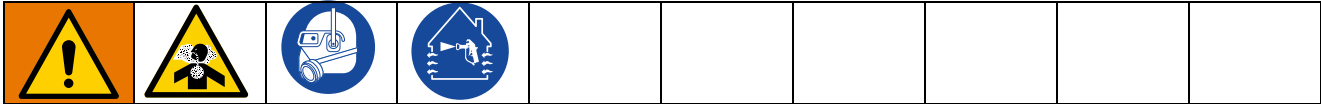

Spraying or dispensing fluids that contain isocyanates creates potentially harmful mists, vapors, and atomized particulates.

- Read and understand the fluid manufacturer’s warnings and Safety Data Sheets (SDSs) to know specific hazards and precautions related to isocyanates.
- Use of isocyanates involves potentially hazardous procedures. Do not spray with this equipment unless you are trained, qualified, and have read and understood the information in this manual and in the fluid manufacturer’s application instructions and SDSs.
- Use of incorrectly maintained or mis-adjusted equipment may result in improperly cured material, which could cause off gassing and offensive odors. Equipment must be carefully maintained and adjusted according to instructions in the manual.
- To prevent inhalation of isocyanate mists, vapors and atomized particulates, everyone in the work area must wear appropriate respiratory protection. Always wear a properly fitting respirator, which may include a supplied-air respirator. Ventilate the work area according to instructions in the fluid manufacturer’s SDSs.
- Avoid all skin contact with isocyanates. Everyone in the work area must wear chemically impermeable gloves, protective clothing and foot coverings as recommended by the fluid manufacturer and local regulatory authority. Follow all fluid manufacturer recommendations, including those regarding handling of contaminated clothing. After spraying, wash hands and face before eating or drinking.
- Hazard from exposure to isocyanates continues after spraying. Anyone without appropriate personal protective equipment must stay out of the work area during application and after application for the time period specified by the fluid manufacturer. Generally this time period is at least 24 hours.
- Warn others who may enter work area of hazard from exposure to isocyanates. Follow the recommendations of the fluid manufacturer and local regulatory authority. Posting a placard such as the following outside the work area is recommended:

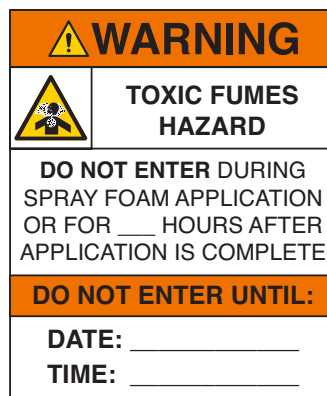

Material Self-ignition



Some materials may become self-igniting if applied too thick. Read material manufacturer's warnings and Safety Data Sheets (SDSs).

Keep Components A and B Separate



Cross-contamination can result in cured material in fluid lines which could cause serious injury or damage equipment. To prevent cross-contamination:

- **Never** interchange component A and component B wetted parts.
- Never use solvent on one side if it has been contaminated from the other side.

Changing Materials

NOTICE

Changing the material types used in your equipment requires special attention to avoid equipment damage and downtime.

- When changing materials, flush the equipment multiple times to ensure it is thoroughly clean.
- Always clean the fluid inlet strainers after flushing.
- Check with your material manufacturer for chemical compatibility.
- When changing between epoxies and urethanes or polyureas, disassemble and clean all fluid components and change hoses. Epoxies often have amines on the B (hardener) side. Polyureas often have amines on the B (resin) side.

Moisture Sensitivity of Isocyanates

Exposure to moisture (such as humidity) will cause ISO to partially cure, forming small, hard, abrasive crystal that become suspended in the fluid. Eventually a film will form on the surface and the ISO will begin to gel, increasing in viscosity.

NOTICE

Partially cured ISO will reduce performance and the life of all wetted parts.

- Always use a sealed container with a desiccant dryer in the vent, or a nitrogen atmosphere. **Never** store ISO in an open container.
- Keep the ISO pump wet cup or reservoir (if installed) filled with appropriate lubricant. The lubricant creates a barrier between the ISO and the atmosphere.
- Use only moisture-proof hoses compatible with ISO.
- Never use reclaimed solvents, which may contain moisture. Always keep solvent containers closed when not in use.
- Always lubricate threaded parts with an appropriate lubricant when reassembling.

NOTE: The amount of film formation and rate of crystallization varies depending on the blend of ISO, the humidity, and the temperature.

Foam Resins with 245 fa Blowing Agents

Some foam blowing agents will froth at temperatures above 90°F (33°C) when not under pressure, especially if agitated. To reduce frothing, minimize preheating in a circulation system.

Typical Installation

Integrated PowerStation

NOTE: Shown with a Reactor 2 hydraulic proportioner.

NOTE: Supply hoses (not provided) between the Reactor 2 proportioner and the Integrated PowerStation cannot exceed 20 ft (6 m) in length.

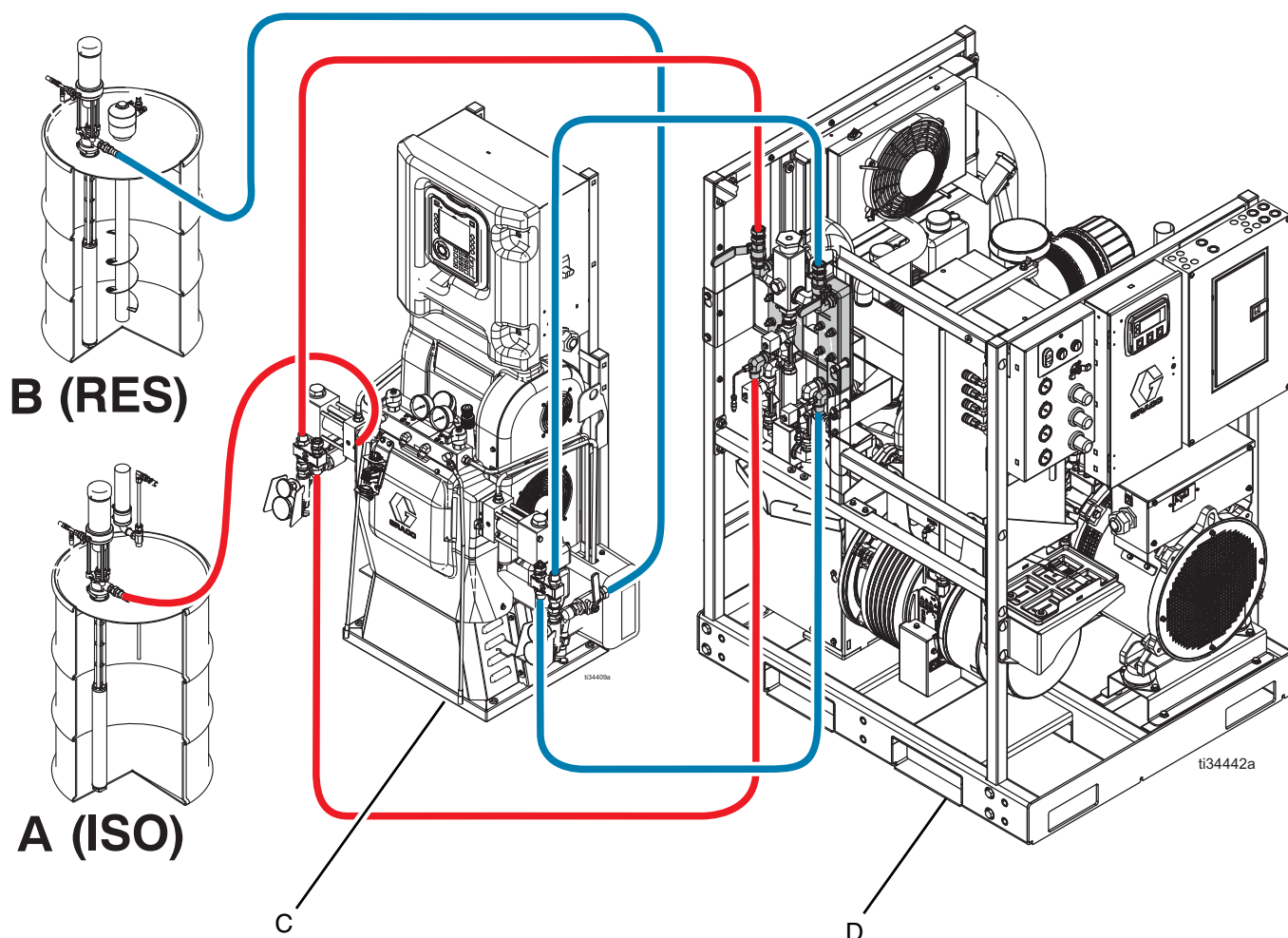

FIG. 1: Typical Installation of the Integrated PowerStation

- A A-side Material (ISO)
- B B-side Material (RES)
- C Reactor 2 Proportioner
- D Integrated PowerStation

With Reactor Pallet, Fuel Tank Pallet, and Fuel Tank Kits

NOTE: Shown with Reactor pallet extension kit (25E306), fuel tank pallet extension kit (25E307), and fuel tank kit (24K390).

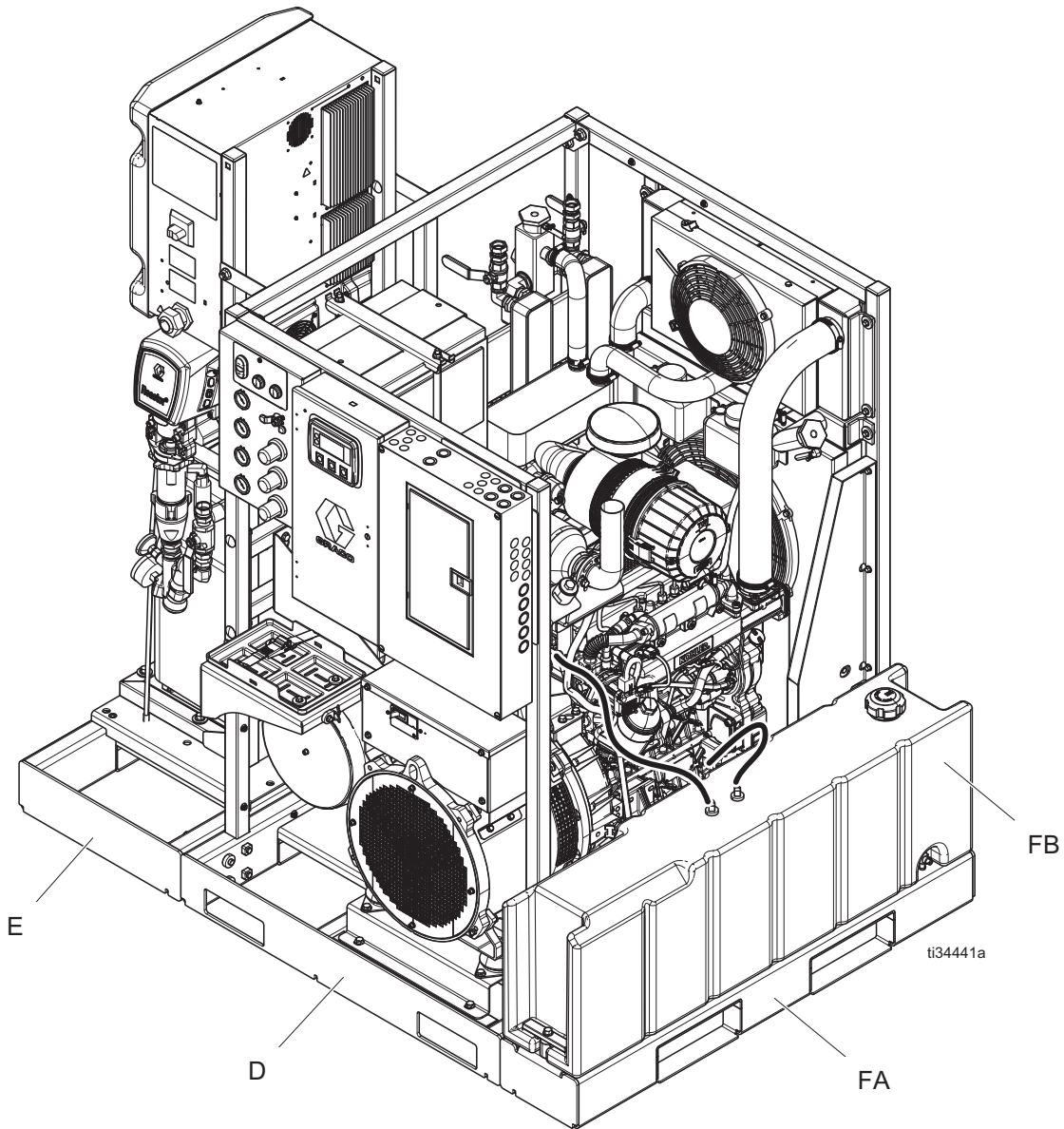

FIG. 2: Installation of the Integrated PowerStation with Reactor and Fuel Tank Pallet Extension Kits

- D Integrated PowerStation
- E Reactor 2 Pallet Extension Kit (25E306)
- FA Fuel Tank Pallet Extension Kit (25E307)
- FB Fuel Tank Kit (24K390)

With Heat Exchanger Relocation Kit

NOTE: Shown with heat exchanger relocation kit (25B067) and optional wall.

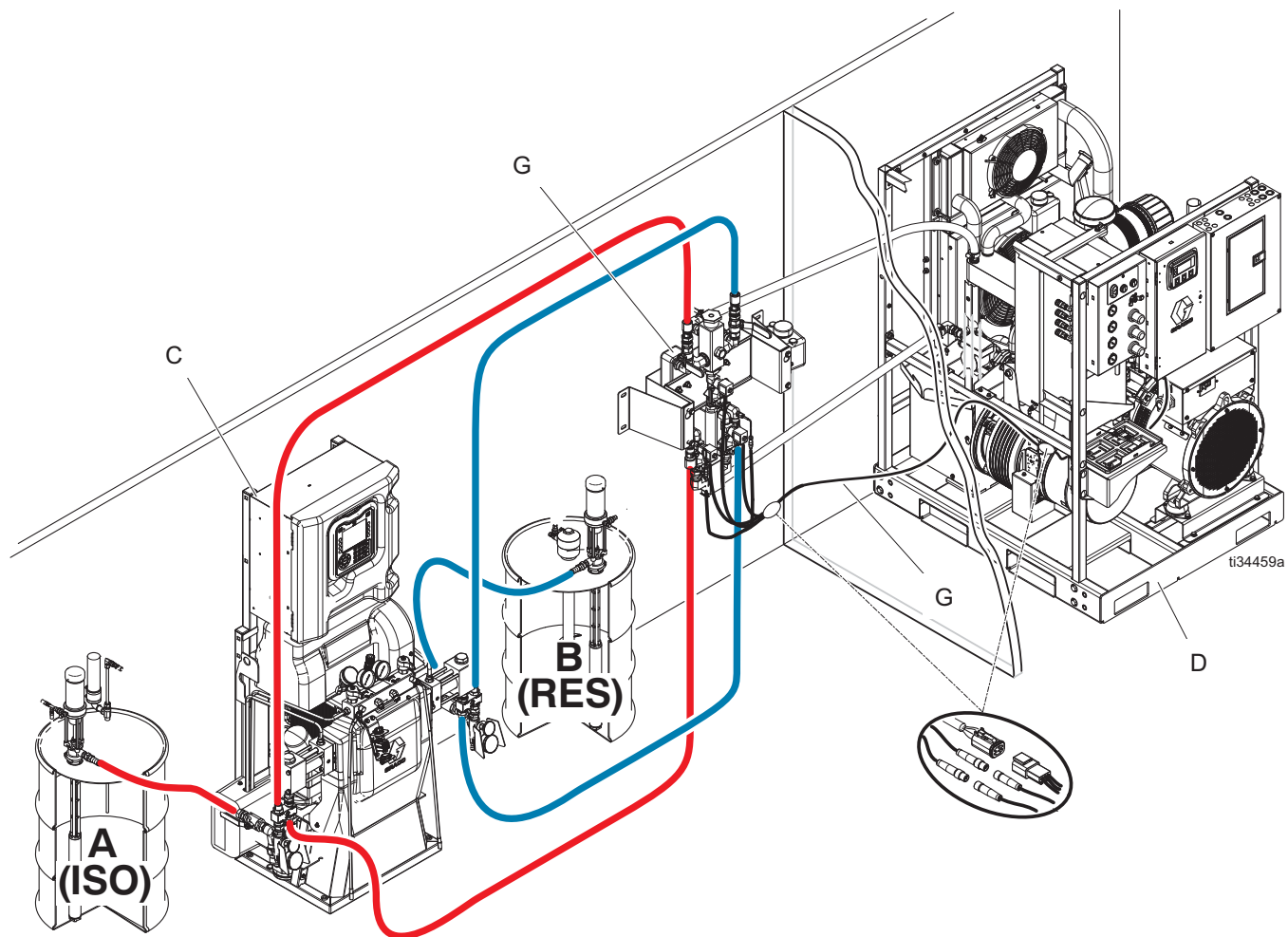

FIG. 3: Installation of the Integrated PowerStation with the Heat Exchanger Relocation Kit

- | | | | |
|---|------------------------|---|---|
| A | A-side Material (ISO) | D | Integrated PowerStation |
| B | B-side Material (RES) | G | Relocated Heat Exchanger and Extension Harness (Kit 25B067) |
| C | Reactor 2 Proportioner | | |

Component Identification

Overview

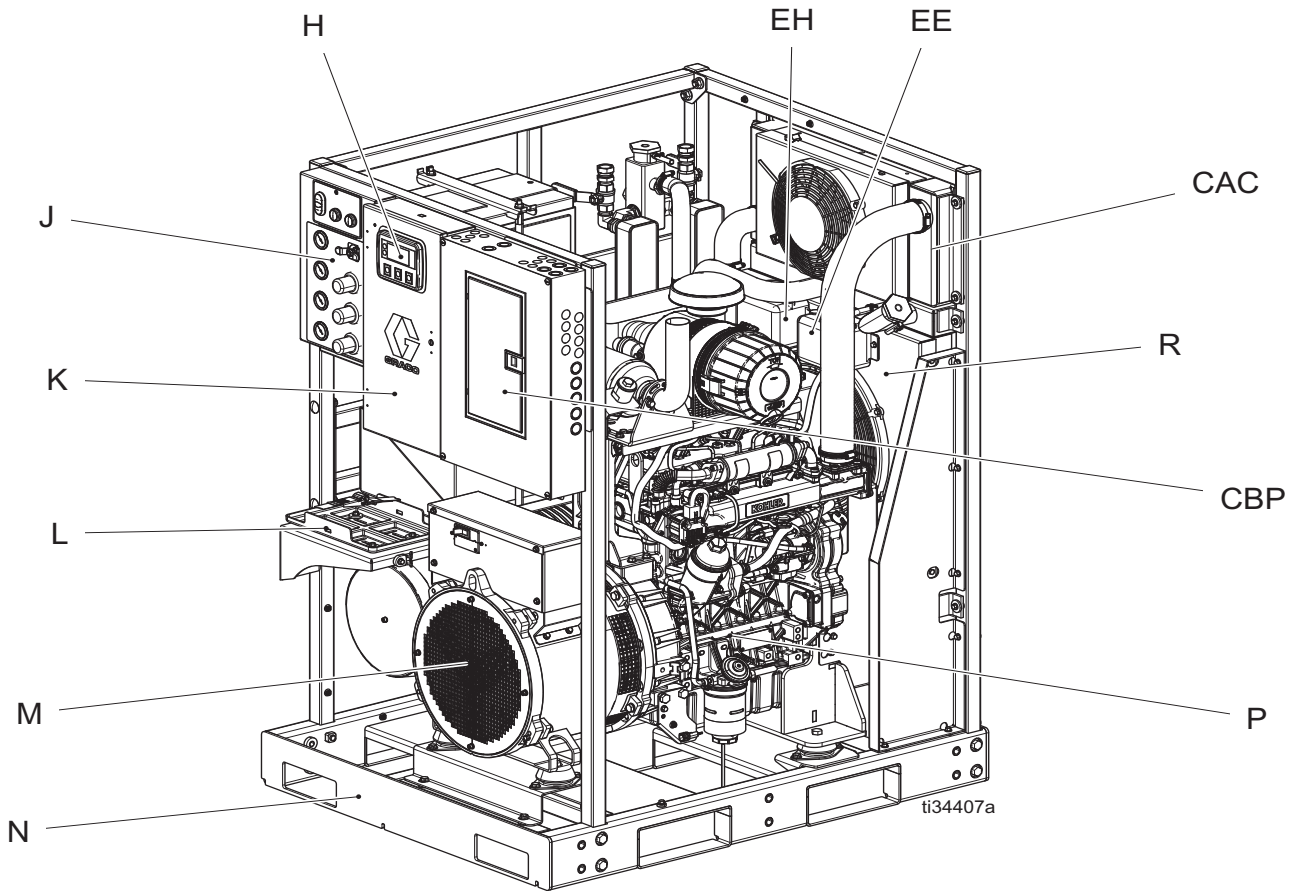

FIG. 4: Integrated PowerStation

H	Engine Display	P	Kohler® Diesel Engine
J	Air Control Panel	CBP	Circuit Breaker Panel
K	Engine Controls Enclosure	R	Radiator
L	Battery Tray	CAC	Charge Air Cooler
M	Alternator	EE	Engine Coolant Expansion Bottle
N	Pallet	EH	Heat Exchanger Coolant Expansion Bottle

Compressed Air and Coolant Components

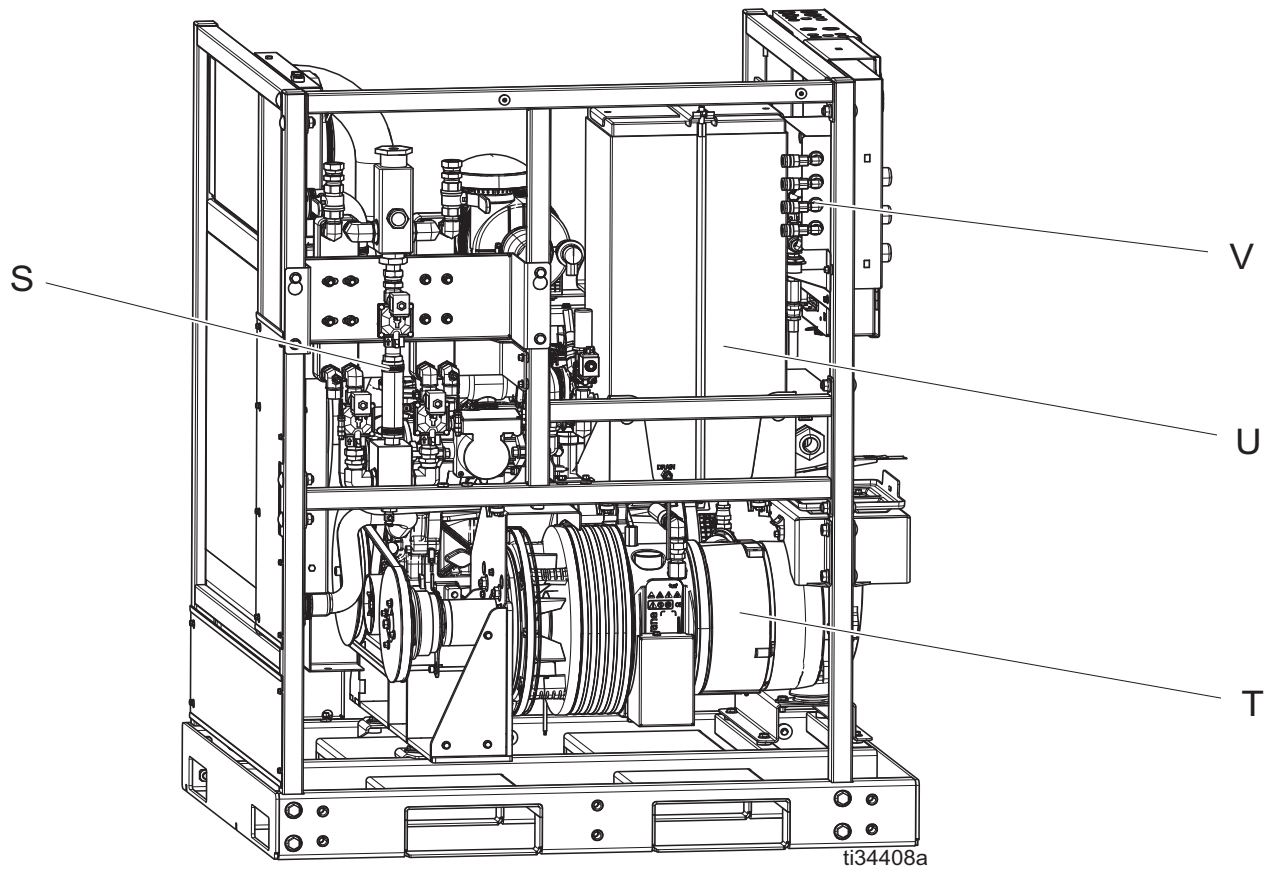

FIG. 5: Compressed Air and Coolant Components

- S Secondary Heat Exchange Assembly
- T Air Compressor
- U Air Dryer
- V Air Connections

Coolant Components

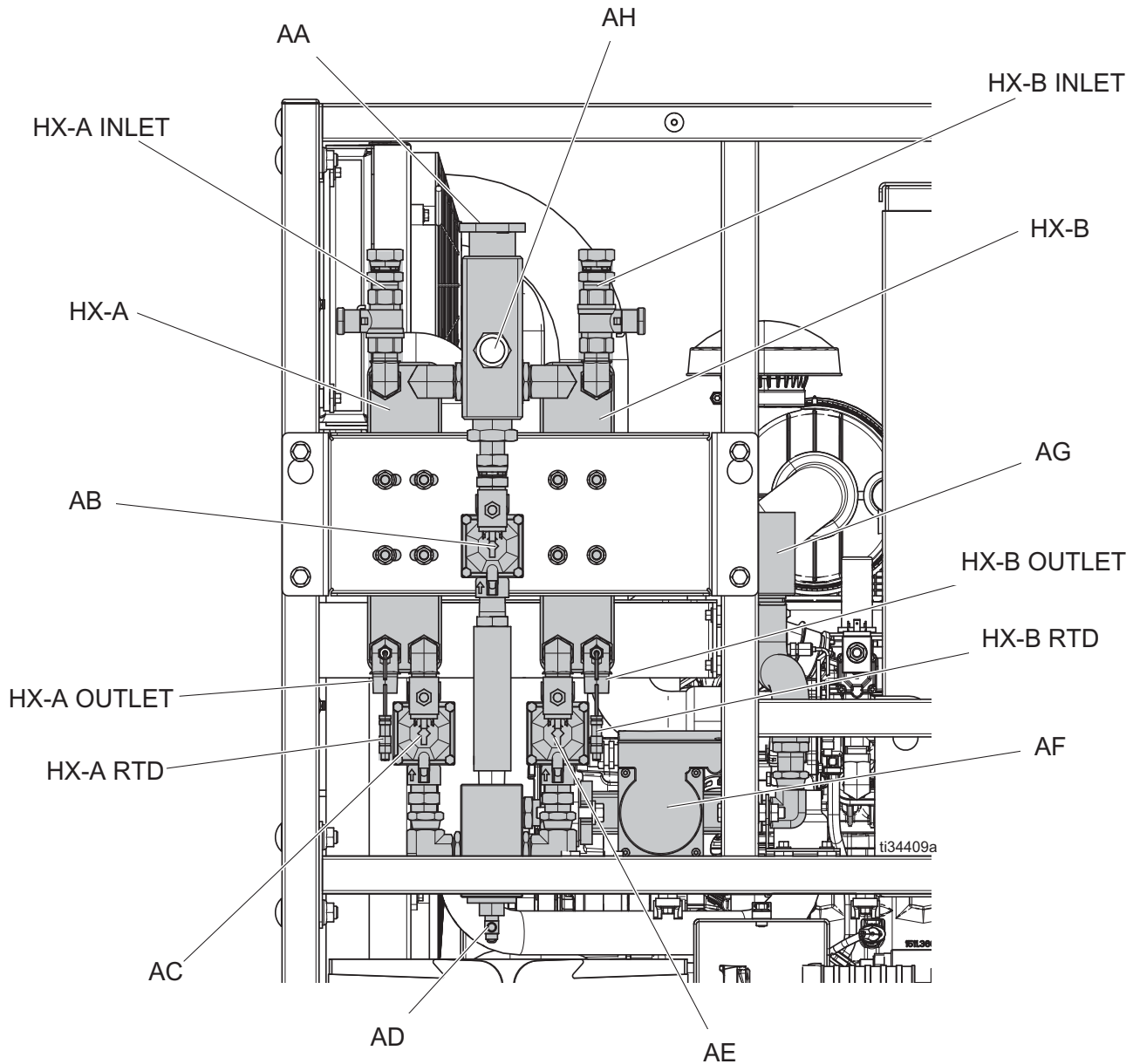

FIG. 6: Coolant Components

AA	Heat Exchange Coolant Fill	AE	B-side Heat Exchanger Coolant Valve
HX-A INLET	A-side Heat Exchanger Inlet	AF	Heat Exchange Coolant Pump
HX-A	A-side Secondary Heat Exchanger	HX-B RTD	B-side Heat Exchanger RTD
AB	Bypass Coolant Valve	HX-B OUTLET	B-side Heat Exchanger Outlet
HX-A OUTLET	A-side Heat Exchanger Outlet	AG	Primary Heat Exchanger
HX-A RTD	A-side Heat Exchanger RTD	HX-B	B-side Secondary Heat Exchanger
AC	A-side Heat Exchanger Coolant Valve	HX-B INLET	B-side Heat Exchanger Inlet
AD	Heat Exchange Coolant Drain	AH	Sight Glass

Single-Side Engine Service

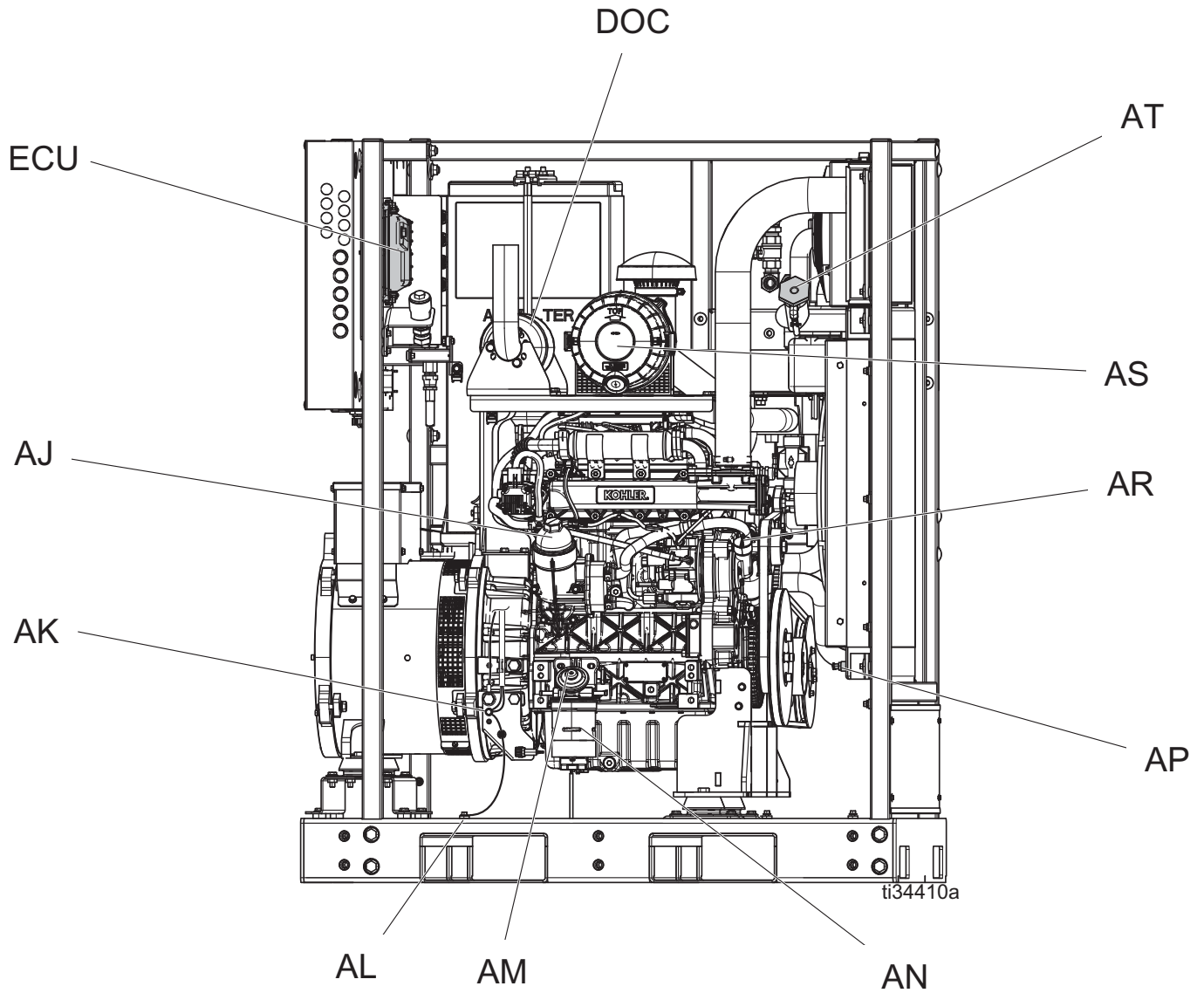

FIG. 7: Single-Side Engine Service

ECU	Engine Control Unit	AP	Engine Coolant Drain
AJ	Oil Filter Assembly	AR	Engine Oil Fill
AK	Engine Single Point Ground	AS	Air Intake Filter Assembly
AL	System Grounding (Bonding) Bolt	AT	Engine Coolant Fill
AM	Fuel Priming Button	DOC	Diesel Oxidation Catalyst
AN	Fuel Filter Assembly		

Engine Controls Enclosure

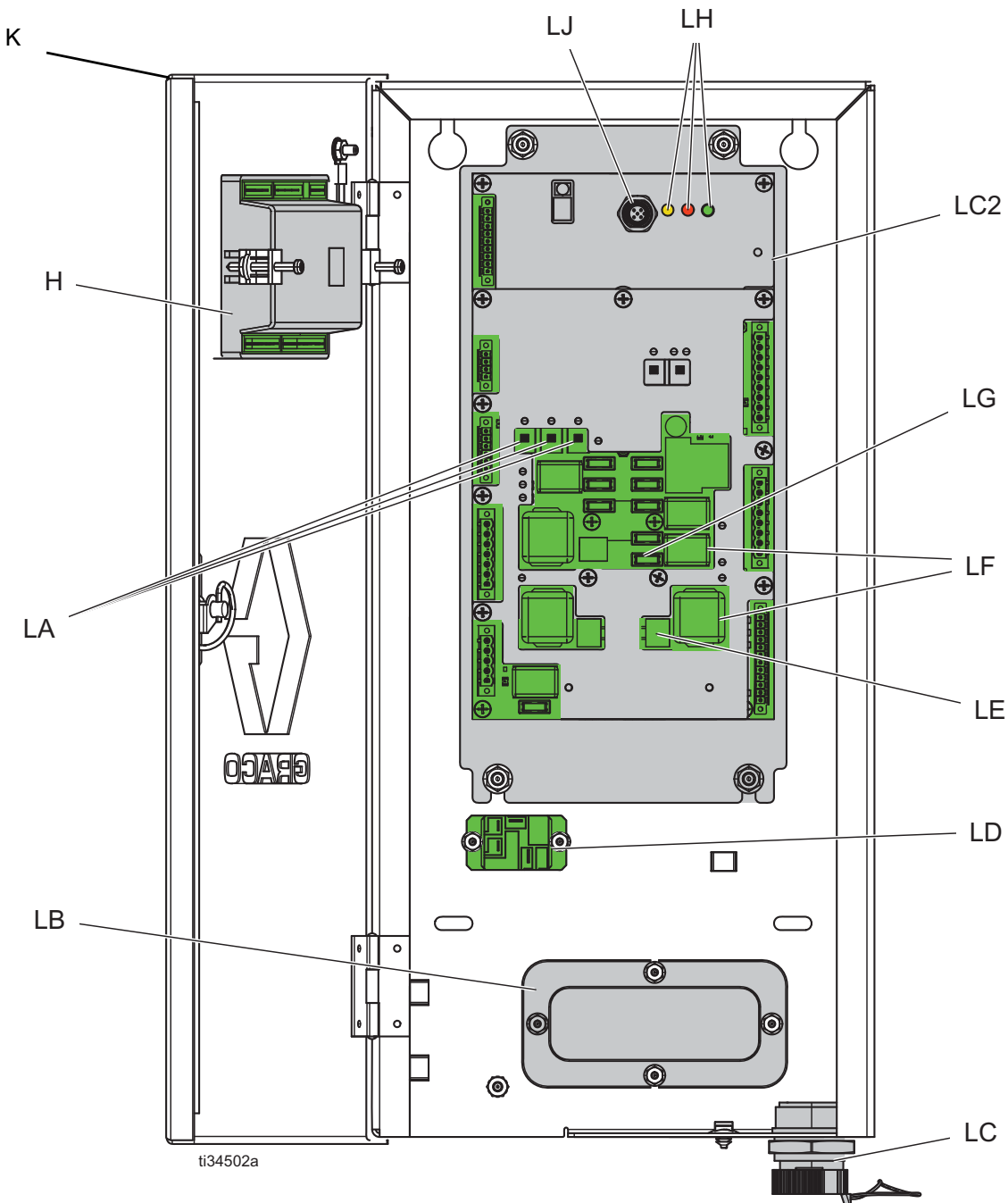

FIG. 8: Engine Controls Enclosure

H	Engine Display	LE	JCASE Series Fuses
K	Engine Controls Enclosure	LF	Relays
LA	Manual Valve Control Switches	LG	MINI Series Fuses
LB	Interface to Engine and ECU	LC2	Load Center 2
LC	Engine Diagnostic (J1939) Connector	LH	Status Lights
LD	Air Compressor Controls Relay	LJ	CAN Connection to Reactor 2

Air Controls Panel

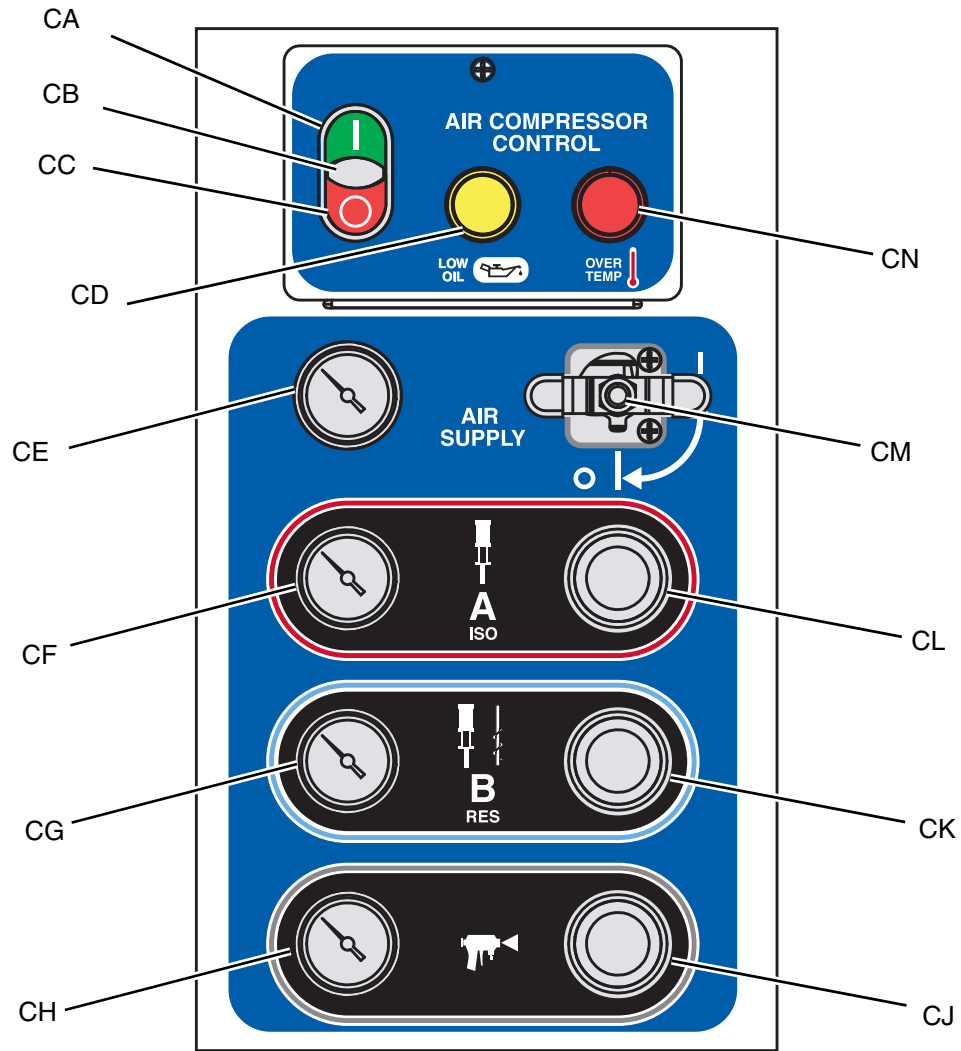

FIG. 9: Air Controls Panel

CA	Air Compressor ON Button	CH	Gun Air Supply Gauge
CB	Air Compressor Power Indicator Light	CJ	Gun Air Regulator
CC	Air Compressor OFF Button	CK	B-side Air Regulator
CD	Air Compressor Low Oil Light	CL	A-side Air Regulator
CE	Main Air Supply Gauge	CM	Main Air Supply Valve
CF	A-side Air Supply Gauge	CN	Air Compressor Over Temperature Indicator Light
CG	B-side Air Supply Gauge		

Installation



Do not remove or separate the engine assembly or circuit breaker panel from the pallet. Failure to leave the component mounting intact can cause unsafe wiring and electric shock. All electrical wiring must be done by a qualified electrician and comply with all local codes and regulations.

NOTICE

Proper system setup, startup, and shutdown procedures are critical to electrical equipment reliability. The following procedures ensure steady voltage. Failure to follow these procedures will cause voltage fluctuations that can damage electrical equipment and void the warranty.

NOTE: Refer to your Reactor 2 proportioner manual for installation and operation procedures.

Locate System

1. Locate the system pallet on a level surface that is nonporous and diesel-resistant, such as diamond plate.

NOTE: For cooling purposes, position the side of the pallet containing the radiator nearest to an external wall containing louvers or suitable openings. For maintenance accessibility, leave at least 1 ft (0.3 m) between all other sides of the pallet and any walls.

2. Operate the system in ambient temperatures above 20°F (-7°C).

NOTICE

To ensure the heat exchanger control valves open and close properly, do not store or operate the system in ambient temperatures below 20°F (-7°C).

3. To mount the system in a trailer:
 - a. Use a forklift or pallet jack to move the system by inserting the forks through the pallet frame.
 - b. Bolt the pallet to the trailer frame.

NOTE: If desired, use the 90° brackets used to hold the system to the wooden pallet during delivery.

NOTE: The maximum allowable length of A (ISO) and B (RESIN) chemical hoses between the Integrated PowerStation and the Reactor 2 is 20 ft (6 m).

Trailer or Vehicle Setup



The exhaust system must be routed away from combustible materials and outside of concealed spaces to reduce the risk of material ignition, fire, and exhaust recirculation. Exhaust recirculation may result in asphyxiation or death.

To reduce the risk of burns from contact with hot surfaces, install exhaust system guards (not provided).

NOTICE

Failure to provide required ventilation can damage the engine and void the engine warranty.

1. Provide sufficient lighting to safely operate and maintain the system equipment.
2. Provide an outlet (such as a louver) for the radiator and charge air cooler (CAC) fans to remove heat from the engine compartment.

NOTE: The outlet must be at least 24 in. (61 cm) wide and 40 in. (102 cm) tall. Failure to provide the required outlet restricts air flow and will void the manufacturer's warranty.

3. Provide flexible shrouding to connect the air flow created by the radiator and CAC fans to the outlet.

NOTE: To prevent hot air recirculation, create an air seal between the radiator, CAC, and outlet.

4. On the side of the trailer opposite the radiator and CAC outlet, provide an air intake of at least 6 sq. ft. (0.56 sq. m) in size.

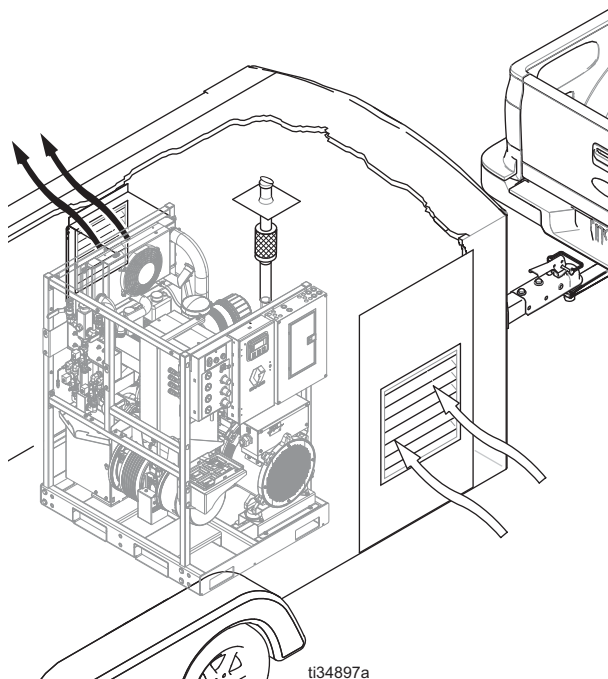

FIG. 10

Exhaust Pipes



Routing the exhaust piping into the radiator and CAC outlet can cause hot air recirculation. Hot air recirculation may result in asphyxiation or death.

1. Remove the engine exhaust cap.
2. Provide an engine exhaust outlet of at least 2 in. (5 cm) diameter, with a flexible pipe element attaching to the provided exhaust outlet. Provide a rain cap, or an equivalent routing, to prevent moisture from entering the exhaust pipe.

NOTE: Exhaust piping must be properly supported and routed to prevent stress on the diesel oxidation catalyst (DOC).

NOTE: If exhaust piping is secured to the system frame or the trailer, install an isolator. The engine assembly is free to vibrate independently of the system frame or the trailer.

NOTE: Exhaust pipes that pass through ceilings must be guarded by vented metal thimbles that:

- Extend at least 9 in. (23 cm) below and above the roof
- Are at least 6 in. (15 cm) in diameter larger than the exhaust pipe

Exhaust pipes that pass through walls must be guarded by either:

- Metal, ventilated thimble at least 12 in. (30 cm) larger than the diameter of the exhaust pipe
- Metal or other approved fireproofing materials that provide at least 8 in. (20 cm) of insulation between the exhaust pipe and flammable material.

Exhaust pipes not covered above must have at least 9 in. (23 cm) of clearance from the outside of the exhaust pipe to adjacent materials.

Grounding



The equipment must be grounded to reduce the risk of static sparking and electric shock. Electric or static sparking can cause fumes to ignite or explode. Improper grounding can cause electric shock. Grounding provides an escape wire for the electric current.

The equipment must be bonded (grounded) to the truck. Grounding reduces the risk of static shock due to static build-up on the equipment. Grounding and bonding must be performed by a qualified electrician. Follow all local codes and regulations.

Pallet: The components on the pallet are bonded (grounded) to the pallet. The pallet must be bonded with an appropriately-sized conductor to the trailer or vehicle chassis. Remove the system grounding (bonding) bolt and engine bonding cable from the pallet. Install a bonding (grounding) cable terminated with a ring terminal under the engine bonding cable. Cable and terminal not supplied. Reinstall the bolt and torque to a minimum of 25 ft-lbs (34 N•m). The ground bus bar in the electrical enclosure is an alternate grounding location. Follow all local codes and regulations.

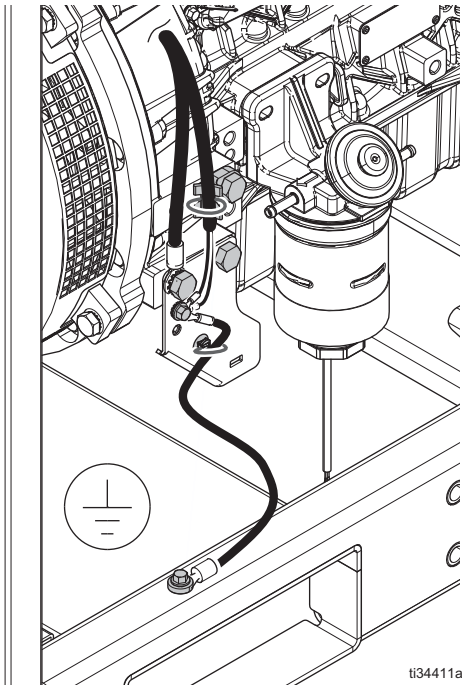

FIG. 11

ti34411a

Connect Battery



Improper battery installation or maintenance may result in electric shock, chemical burns, or explosion. Battery maintenance must only be performed or supervised by personnel knowledgeable of batteries and the required precautions. Keep unauthorized personnel away from batteries.

Battery Requirements	
Voltage	12 Vdc
Minimum Cold Cranking Amps (CCA)	800 CCA
Connection Type	Post

1. Secure the battery (not supplied) to the bracket with the included strap. Locate the red, positive (+) battery terminal near the outer edge of the system.
2. Connect the battery cable from the engine starter and chassis to the battery.
 - a. Connect the red battery cable from the engine starter and load center to the positive (+) terminal of the battery.
 - b. Leave the black battery cable disconnected.

NOTE: When the black battery cable is connected, the system is energized. Do not connect the black cable until **Connect Air Lines** (page 28) are complete.

NOTICE

Always connect the red battery cable to the battery positive terminal (+) and the black battery cable to the battery negative terminal (-). Failure to properly connect the battery cable to the battery will damage the fusible link. Do not bypass the fusible link when damaged. The fusible link prevents damage to other system components.

3. Cover the positive (+) terminal of the battery with the protective cover attached to the supplied battery cable.

Secure Fuel Tank

1. Secure the fuel tank on or above a level surface that is nonporous and diesel-resistant, such as diamond plate.

NOTE: The supply fuel line and the return fuel line must not exceed 10 ft (3 m) in length apiece. The supply and return fuel lines are provided. Fuel lines longer than 10 ft (3 m) may cause damage to the engine and void the manufacturer's warranty. If a longer fuel line is desired, a lift pump is mandatory. Refer to the Kohler engine manual for further information.

NOTE: Do not locate the fuel tank supply port (AV) and the fuel tank return port (AU) more than 3 vertical feet (0.9 m) from the fuel filter.

2. Connect fuel supply and return lines from the diesel engine to the fuel tank using the lines coiled and secured to the side of the engine.

NOTE: To prevent reduced power output, fuel return port (AU) in customer-supplied fuel tanks must be located at least 20 in. (50.8 cm) away from the supply port (AV).

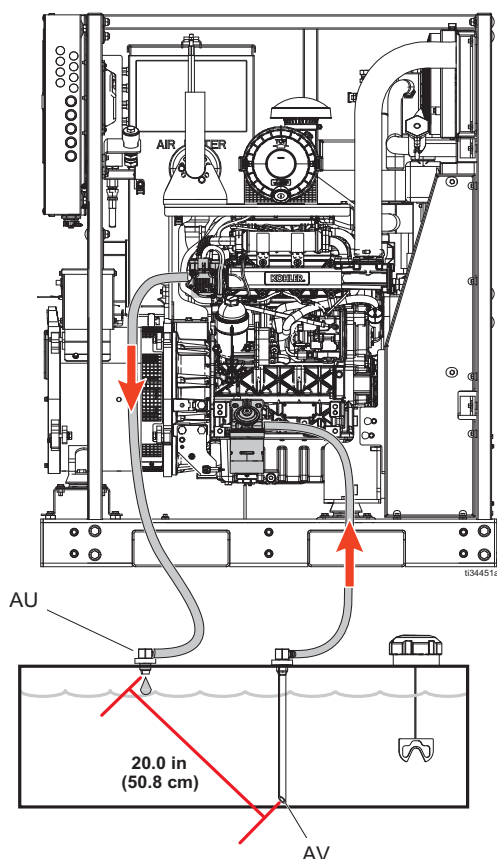

Fig. 12: Fuel Supply and Return Lines

Add Fuel

1. Refer to the Kohler engine manual for approved diesel fuels.
2. Fill the fuel tank with the recommended diesel fuel. In installations including the Graco fuel tank, remove the fuel tank cap and fill the tank with no more than 20 gal. (75 L) of diesel fuel. Replace the cap.
3. Prime the engine. Press the fuel priming button (AM) on the fuel filter assembly (AN) repeatedly. The engine is primed once fuel returns to the fuel tank through the return fuel line or the amount of pressure required to press the prime button increases.

Install Heat Exchanger Relocation Kit (25B067)

NOTE: The heat exchanger relocation kit (25B067) is optional.

1. If the system has previously been operated, perform **Daily Shutdown** (page 38) and the **Pressure Relief Procedure** (page 37).
2. If the system has already been run with A and B chemical:
 - a. Close A and B chemical ball valves at the secondary heat exchanger inlets (HX-A INLET, HX-B INLET).
 - b. Drain A and B chemical from the heat exchangers by loosening and removing the RTD from the outlet fittings (HX-A OUTLET, HX-B OUTLET).

NOTE: Before removing the RTD, measure the length of RTD that extends from the compression fitting. When reinstalling the RTD, ensure the same length of RTD is visible.

3. Drain coolant from the secondary heat exchange assembly by opening the coolant drain (HX COOLANT DRAIN).
 - a. Drain the coolant faster by removing the heat exchanger coolant fill cap (HX COOLANT FILL).
 - b. Connect the black battery cable.

NOTE: When the black battery cable is connected, the system is energized.

- c. Open the engine controls enclosure (K). Manually open the A, B, and bypass coolant valves (LA) using the switches on the Load Center 2 (LC2) board. See FIG. 8, page 16.

NOTE: In order to operate the manual coolant valves, the system must be energized.

NOTE: Flip the individual valve switches (LA) to open the coolant valves. When a coolant valve is open, the corresponding LED indicator will illuminate.

- d. Remove the heat exchange overflow bottle from the radiator shroud. Raise the bottle and hose above the fill port to drain all fluid from the coolant loop.
 - e. When the coolant is drained, close the A, B, and bypass coolant valves. Reinstall the fill cap and close the coolant drain (HX COOLANT DRAIN).
 - f. Disconnect the black battery cable.
4. Loosen the swivel connection between the coolant circulation pump and the lower manifold block.

NOTE: To help disconnect the swivel connection, loosen the coolant circulation pump bracket from the frame.

5. Remove the coolant hose connecting the heat exchange coolant fill bottle and the primary engine coolant heat exchanger. Discard the coolant hose.
6. Remove the hose barb from the heat exchange coolant fill bottle. Replace the barb with the swivel fitting.

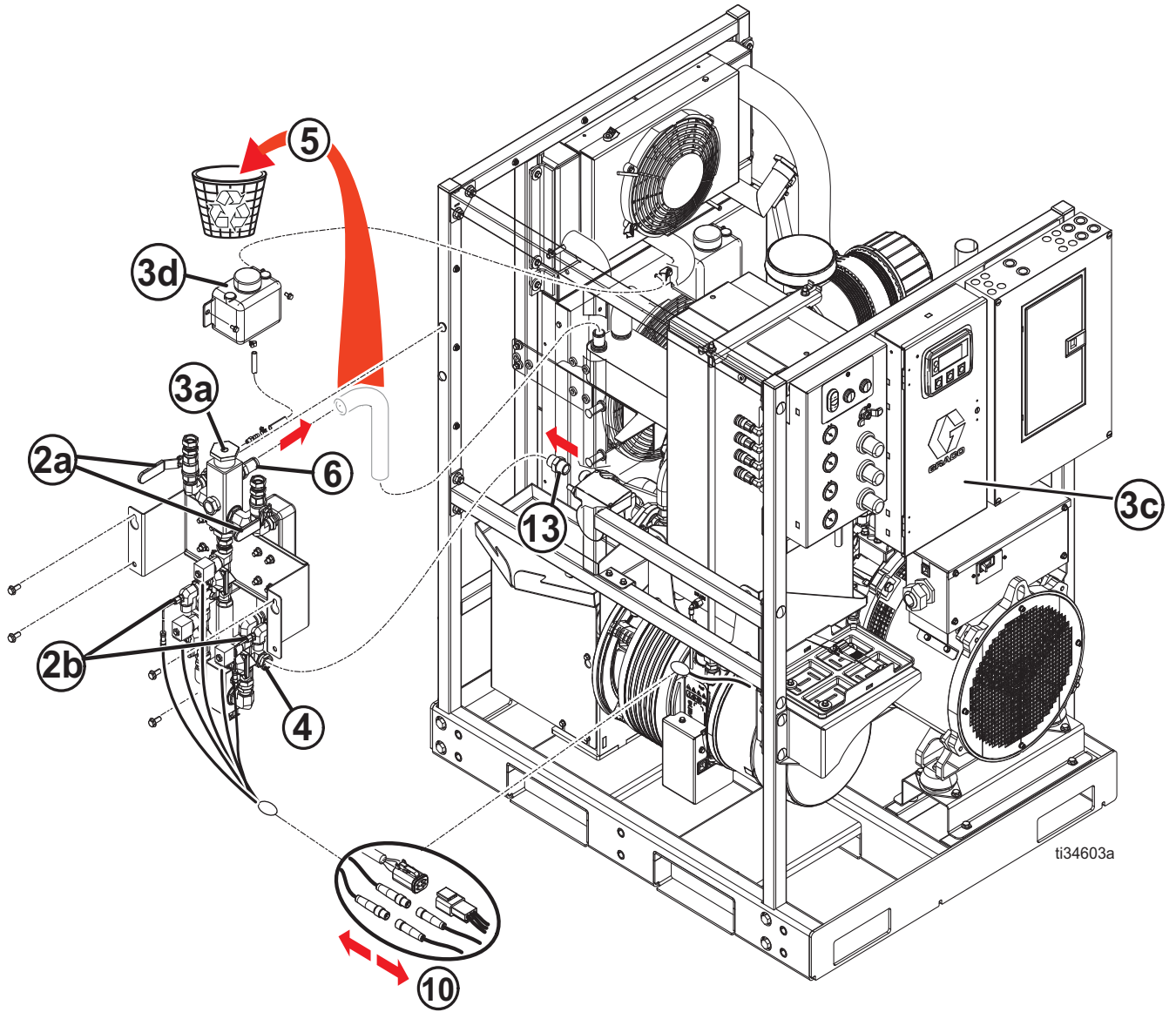

ti34603a

FIG. 13: Disconnect the Heat Exchanger

Installation

7. Install the street elbow hose barb fitting (RE) onto the swivel fitting (RF). See FIG. 14.
8. Secure the heat exchange relocation bracket (RH) at the same height as the heat exchanger was mounted on the system.

NOTE: Heat exchangers mounted too low or too high will not drain or fill properly.

NOTE: The overflow port on the coolant fill bottle must be the highest point in the coolant loop. The heat exchange coolant drain must be the lowest point in the coolant loop.

9. Install 3/8 in. bolts (RL) loosely into the relocation bracket (RH).
10. Disconnect the RTD and coolant valve electrical connections.
11. Remove the heat exchange assembly from the Integrated PowerStation. Install the heat exchange assembly on the relocation bracket (RH).
12. Install the hose barb (RJ) into the swivel on the lower manifold block.
13. Remove the nipple on the coolant circulation pump flange. Replace the nipple with the hose barb.
14. Install the pump bracket (RN) using two 1/4 in. flange head bolts (RG) and two 7/16 in. flange nuts (RP).
15. Install the coolant hose between the fill bottle barb and the primary heat exchange barb. Use hose clamps (RD) to secure the hose to the hose barbs on each end.

NOTE: Each coolant hose between the system and the relocated heat exchange assembly cannot exceed 10 ft (3 m).

16. Install the coolant hose between the lower manifold block and the coolant circulation pump. Use hose clamps (RD) to secure the hose to the hose barbs on each end.

NOTE: Each coolant hose between the system and the relocated heat exchange assembly cannot exceed 10 ft (3 m).

17. Install the RTD and coolant valve extension harness (RM).
18. Install protective shroud (RC) and edge guard (RA) using 3/8 in. bolts (RB).
19. Refill the coolant loop.
 - a. To fill the coolant loop faster, energize the system by connecting the black battery cable. Manually open the A, B, and bypass coolant valves using the switches on the Load Center 2 (LC2) board.
 - b. To avoid draining the battery, close the valves once the coolant loop has been filled.

20. Disconnect the black battery cable.

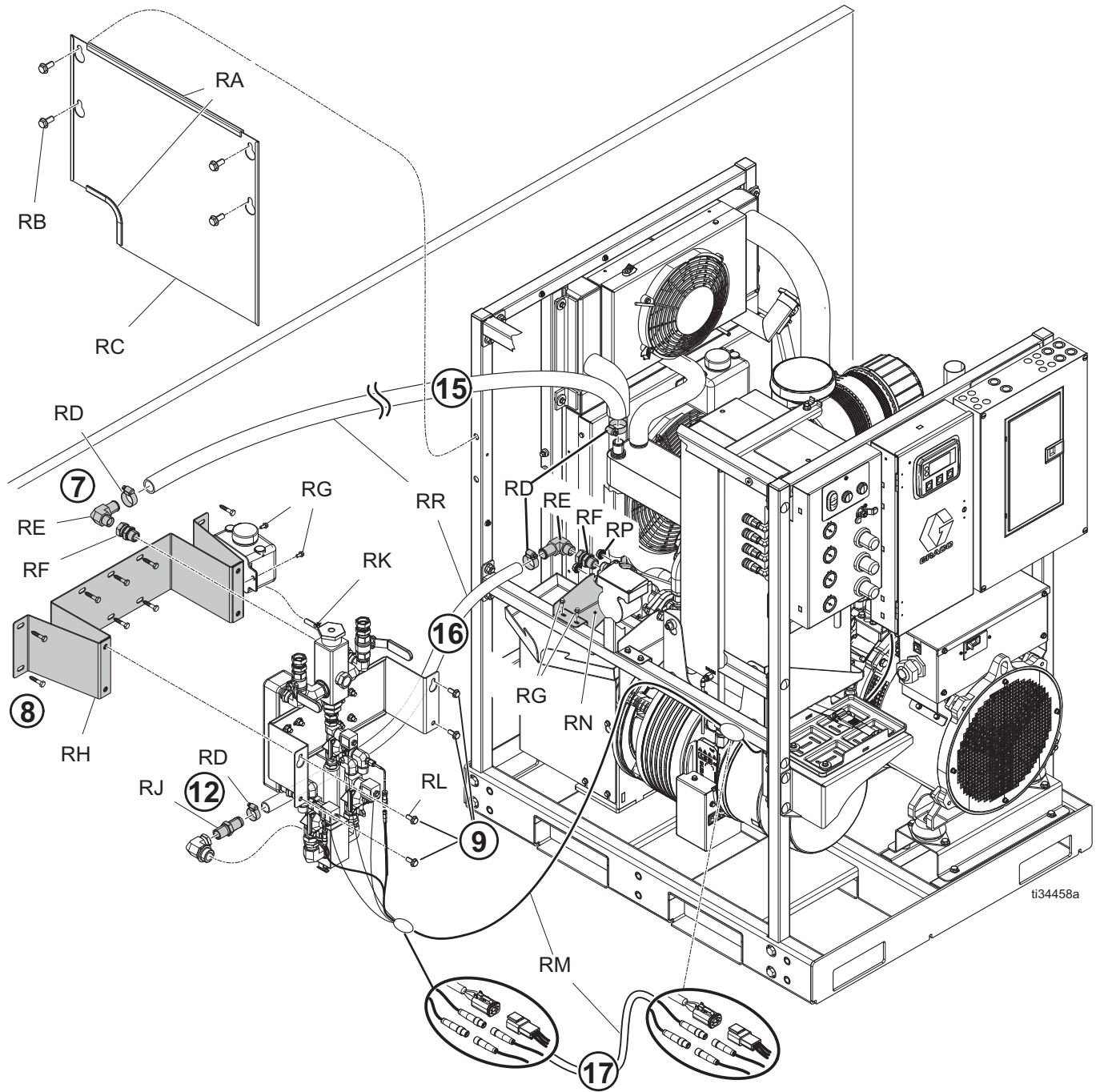

FIG. 14: Relocate the Heat Exchanger

Connect Component A and B Hoses

NOTE: If your installation will include the optional heat exchanger relocation kit (25B067), relocate the heat exchanger before connecting component A and B hoses.

1. Separate the Reactor 2 proportioner fluid inlet screen assemblies (BB) from the Reactor 2 pump lowers (BA). See FIG. 16.
2. Mount the chemical supply manifolds (AZ) to the Reactor 2 pump lowers. Connect the manifold port to the appropriate pump lower using the loose fitting (AY) provided.

NOTE: The A-side and the B-side pump fittings must be installed on the chemical supply manifolds (AZ) before attaching to the pump lower (BA). See FIG. 15 and FIG. 16.

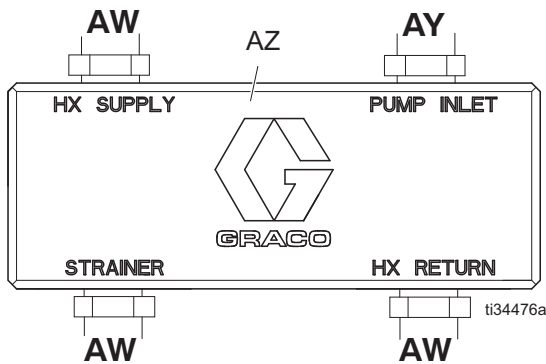

FIG. 15: Chemical Supply Manifold

E-30, E-XP2		
Ref.	Part	Description
AW	C20487	FITTING, nipple, hex
AY	16W967	FITTING, swivel, 3/4 npt x 1 npsm
H-30, H-XP2		
Ref.	Part	Description
AW	C20487	FITTING, nipple, hex
AY	118459	FITTING, union, swivel, 3/4 in.

NOTE: The chemical supply manifolds (AZ) are universal and can be installed on either side of the Reactor 2 proportioner.

3. Connect the Reactor 2 inlet strainer assemblies (BB) to the fitting (AW) installed on the STRAINER port on the chemical supply manifolds. See FIG. 15.
4. Connect the supply hoses from the feed pumps to the component A and B fluid inlet strainer assemblies (BB). Ensure that the A and B valves are closed.

NOTE: The minimum inside diameter of the supply hoses from the transfer pumps is 3/4 in. (1.9 cm) ID.

NOTE: For Reactor 2 hydraulic proportioners, install inlet sensors between the A and B inlet strainer assemblies (BB) and the chemical supply manifold STRAINER fitting (AW).

5. Install the A and B component supply hoses between the fitting (AW) on the HX SUPPLY port of the chemical supply manifolds (AZ), and the secondary heat exchanger A and B inlet ports (HX-A INLET, HX-B INLET). See FIG. 6, FIG. 15, and FIG. 16.

NOTE: The maximum allowable length of A (ISO) and B (RESIN) chemical hose between the Integrated PowerStation and the Reactor 2 is 20 ft (6 m) per hose.

6. Connect the A and B component supply hoses between the secondary heat exchanger outlet ports (HX-A OUTLET, HX-B OUTLET) and the fitting (AW) in the HX-RETURN ports of the A and B chemical supply manifolds.

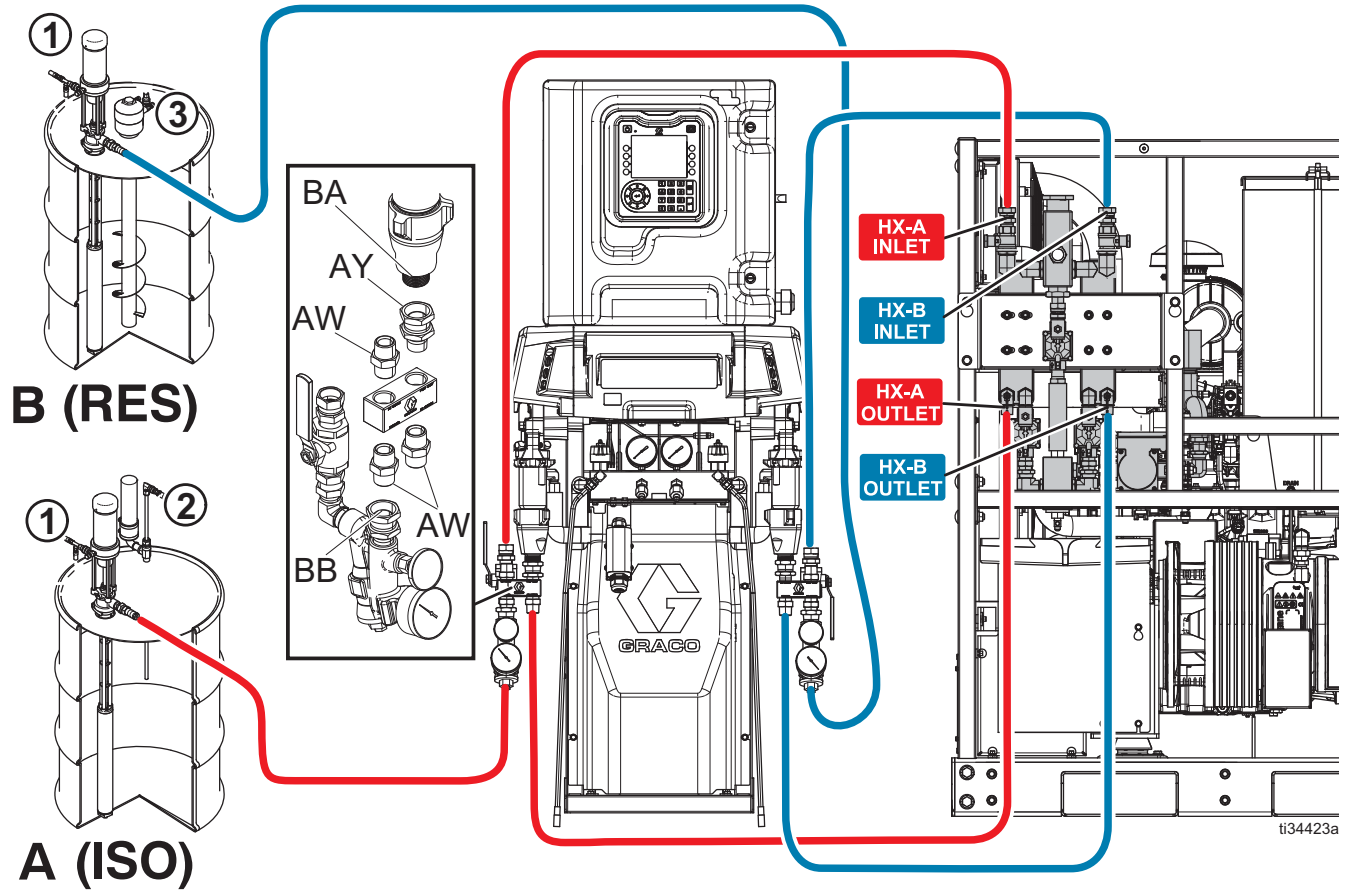

FIG. 16: Supply Hose Connections

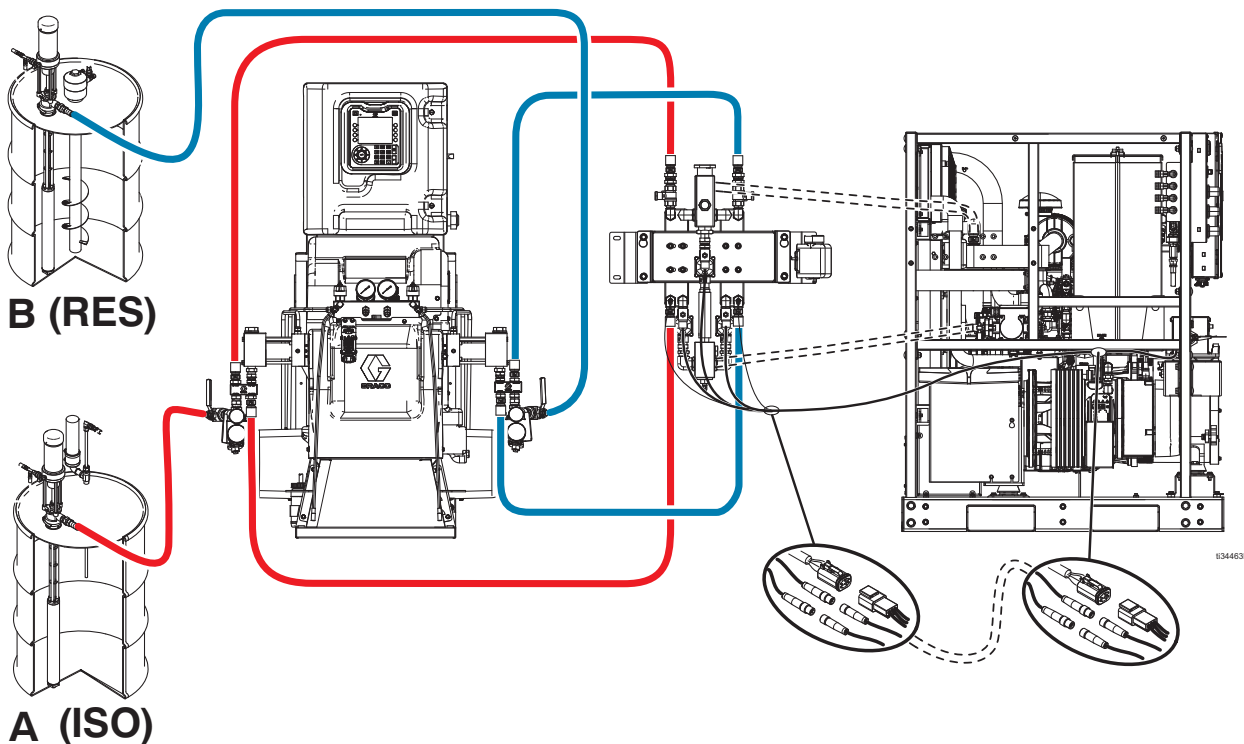

FIG. 17: Supply Hose Connections with Heat Exchanger Relocation Kit

Connect Air Lines

Connect the A and B transfer pumps, spray gun, and agitator air supply lines to the corresponding quick-disconnects on the air control panel. See FIG. 18.

NOTE: The agitator air connection includes a small internal restriction orifice to limit the air flow and minimize the air compressor load. The maximum supplied airflow is 2.0 scfm (0.1 m³/min) at 100 psi (0.7 MPa, 7 bar). The system is designed for use with the Twistork[®] agitator 224854. Do not use the agitator air connection for any other component.

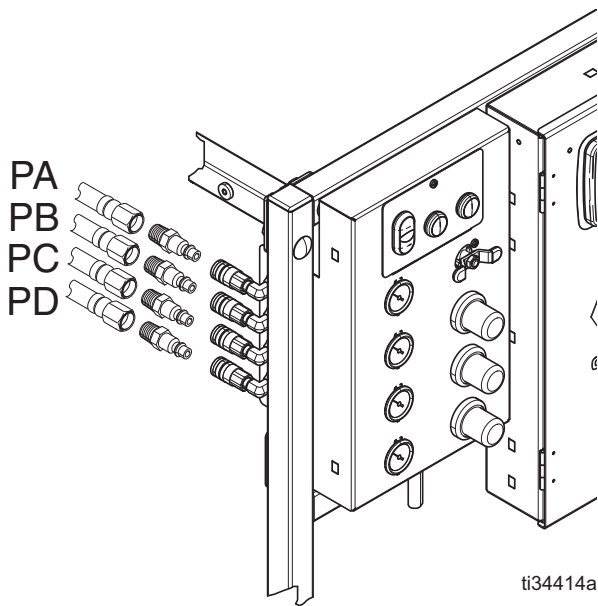

FIG. 18: Air Line Connections

Ref.	Air Outlet
PA	A Pump
PB	B Pump
PC	Agitator
PD	Gun

Electrical Connections

All electrical wiring must be done by a qualified electrician and comply with all local codes and regulations.				

Reactor 2 Heater Rod Wiring

1. Remove the protective shrouding over the Reactor 2 heater block(s).
2. Identify the A-side and B-side remote temperature devices (RTD). Identify the heater rod that shares a port with the RTD in the heater block(s).
3. Leave the heater rod wire pair nearest to the A-side and B-side RTDs connected. Disconnect all other heater rod wire pairs from the Reactor 2. See FIG. 19 and FIG. 20.

NOTE: Do not remove the heater rods from the heater block.

4. Install the provided twist-on wire connectors (TW) onto each disconnected heater rod wire pair.
5. Coil the wire pairs together and secure the wire pairs with cable ties (provided).
6. Reinstall the protective shrouding over the Reactor 2 heater block(s).

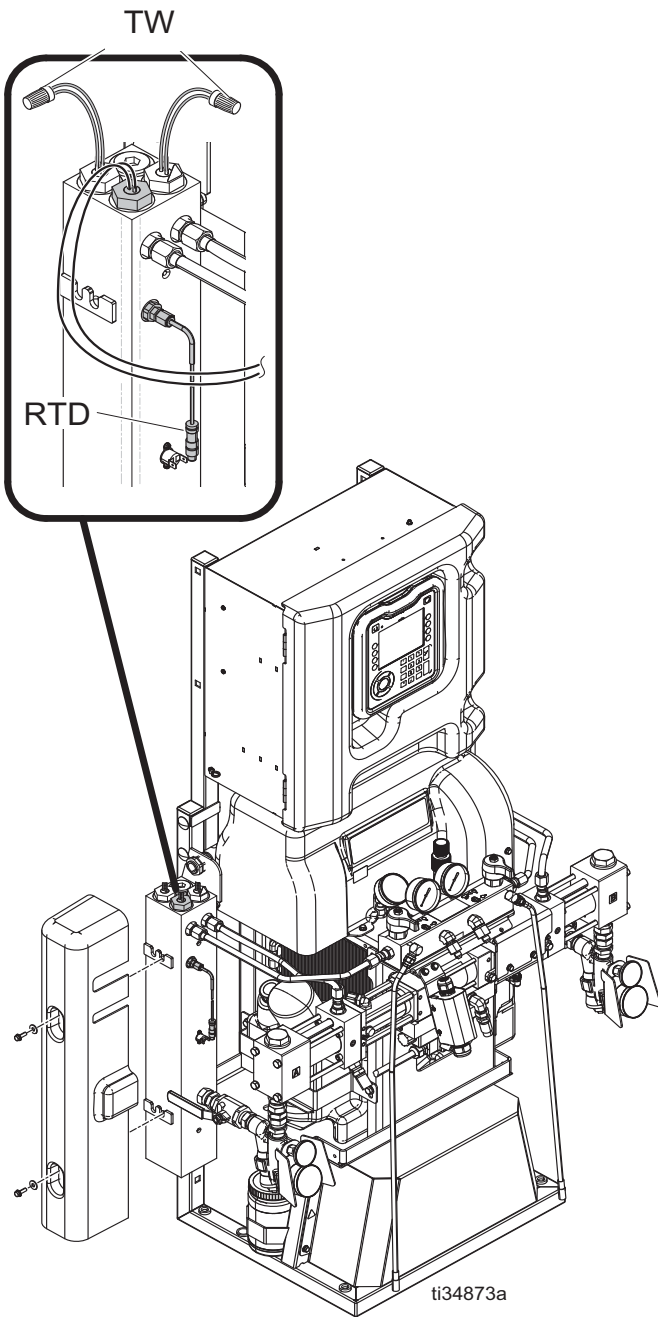

FIG. 19: Hydraulic Reactor Heater Rods (A-side)

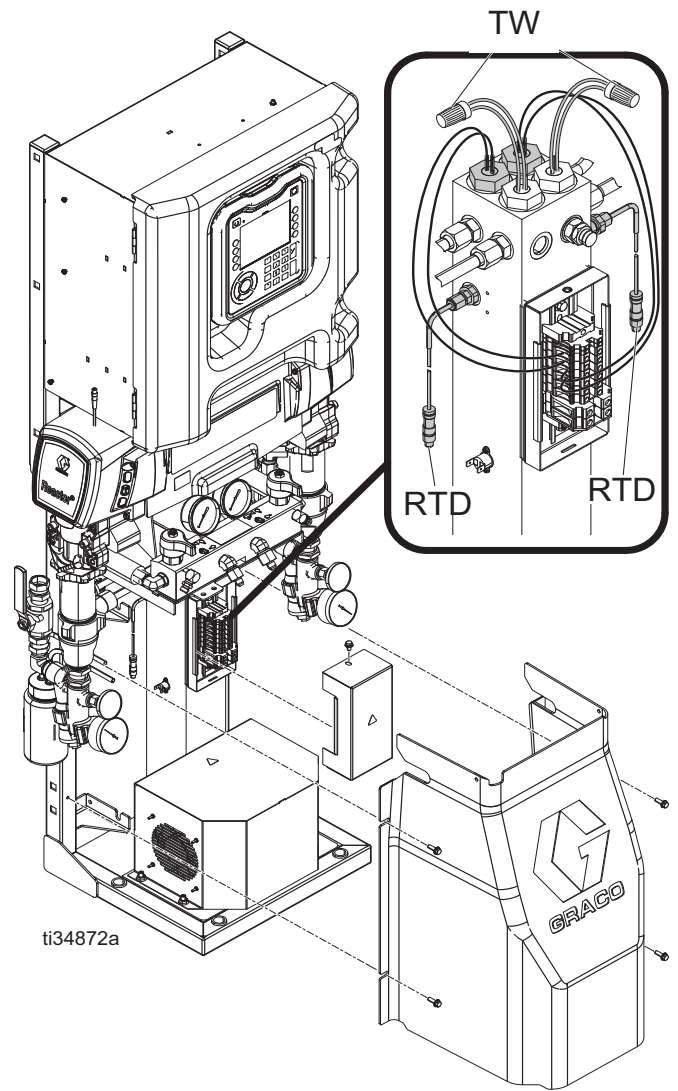

FIG. 20: Electric Reactor Heater Rods

CAN Communication Connections

1. Route the M12 CAN cable (ZE) into the Reactor 2 enclosure (ZC) through the rear grommet. See FIG. 21.

NOTE: The M12 CAN cable (ZE) is stored on the battery tray for shipping purposes only. The M12 CAN splitter (ZD) is shipped loose.

2. Once inside the Reactor 2 enclosure, connect the M12 CAN splitter connection (ZD, -P412) to the M12 CAN cable connection (ZE, -J412).
3. Remove the M12 CAN connection (ZB) from the M12 CAN connector (ZA).
4. Connect the M12 CAN connection (ZB) to the M12 CAN splitter (ZD, -P413).
5. Connect the M12 CAN splitter (ZD, -P414) to the M12 CAN connector (ZA).
6. Verify that the M12 CAN cable (ZE, -P401) is connected to the CAN connector (ZF) in the Integrated PowerStation engine controls enclosure.

Power Connections

1. Install a circuit breaker (not supplied) for the Reactor 2 in the Integrated PowerStation circuit breaker panel. Refer to your Reactor 2 proportioner manual for instructions on circuit breaker size.
2. If desired, install any auxiliary equipment circuit breaker(s) into available space in circuit breaker panel locations.

NOTE: See **Technical Specifications**, page 40, for available auxiliary power.

3. Remove necessary knock-outs on the Integrated PowerStation circuit breaker panel (CBP). See FIG. 4, page 12.
4. Install bulkhead strain reliefs (not provided) where the knock-outs are removed from the circuit breaker panel.
5. Route and install a power cable (not supplied) from the Integrated PowerStation circuit breaker panel to the Reactor 2. Refer to your Reactor 2 proportioner manual for instructions on power cord size.

NOTE: The system generates 240 V, 1-phase. Refer to your Reactor 2 proportioner manual for wiring and jumper configuration.

6. Ground the Reactor 2 to the circuit breaker panel through the power cable connection.
7. Connect the black, negative (-) battery cable to the negative (-) battery terminal. Secure the battery terminal protective cover, attached to the battery cable, over the battery cable connection.

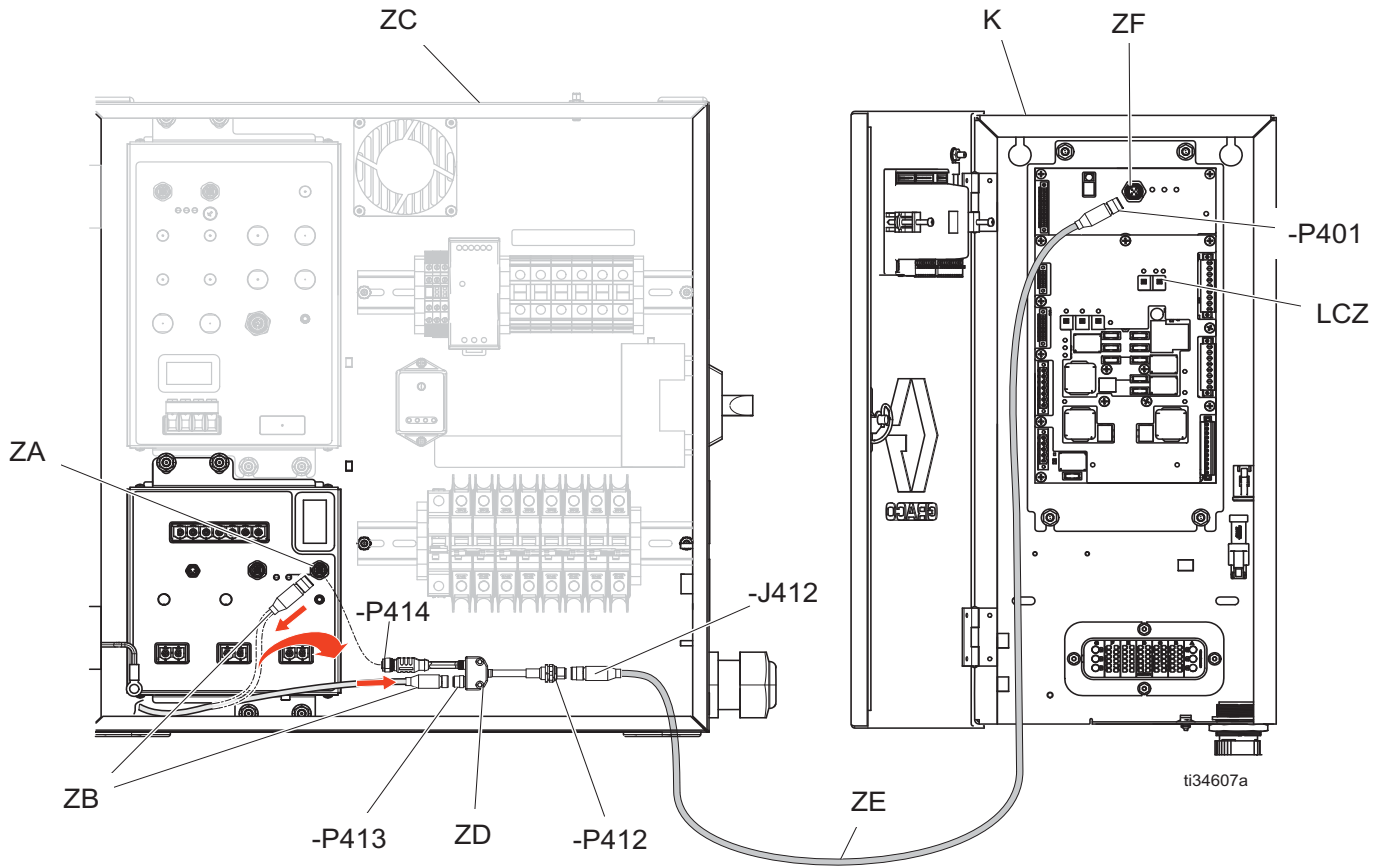





FIG. 21: Electrical Connections Between the Reactor 2 Enclosure and the Engine Control Enclosure

Ref.	E-30, E-XP2	H-30, H-XP2
K	Engine controls enclosure	
LC2	Load center 2 (25D410)	
ZA	CAN connector (TCM)	CAN connector (HCM)
ZB	TCM-CAN	TCM-CAN HCM
ZC	Reactor 2 enclosure	
ZD	M12 CAN splitter (17E418)	
ZE	M12 CAN cable (17X599)	
ZF	CAN connector (LC2)	

Operation

To prevent serious injury, only operate the system with all covers and shrouds in place.

NOTICE

Proper system setup, startup, and shutdown procedures are critical to electrical equipment reliability. The following procedures ensure steady voltage. Failure to follow these procedures will cause voltage fluctuations that can damage electrical equipment and void the warranty.

1. Check the diesel fuel level. Running out of fuel during system operation will cause voltage fluctuations that can damage the electrical equipment.
2. Check coolant levels. Check that the levels of coolant inside the engine coolant and heat exchanger coolant expansion bottles (EE, EH) are equal to the COLD level shown on the bottle label. See FIG. 4, page 12.
3. Before starting the Integrated PowerStation, confirm that the main power switch on the alternator is OFF.

NOTE: The engine will not start if the main 90 A circuit breaker is in the ON position.

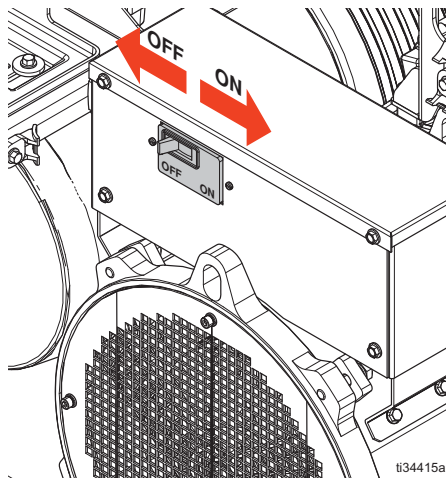

FIG. 22: 90 A Circuit Breaker in OFF Position

4. Activate the engine display by pressing any button.

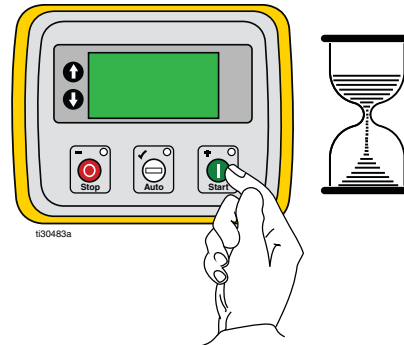



FIG. 23: Engine Display

5. Start the Integrated PowerStation. Press the start button  on the engine display. Verify that the voltages displayed on the engine display are approximately 120 VAC (L/N) before continuing.

NOTE: Once the start button on the engine display is pressed, the controller will automatically begin engine grid heater warming and start operation.

NOTICE

To prevent damage to the engine starter, wait at least one minute between start attempts.

6. Turn the main 90 A circuit breaker on the alternator to ON. See FIG. 22.
7. When starting the system for the first time or restarting the system after performing maintenance, follow **First Time Startup**. See page 35.

8. Before turning on the air compressor:
 - a. Close the main air supply valve (CM) on the air control panel. See FIG. 24.
 - b. Ensure all air regulators (CJ, CK, CL) on the air compressor control panel are fully turned counterclockwise.

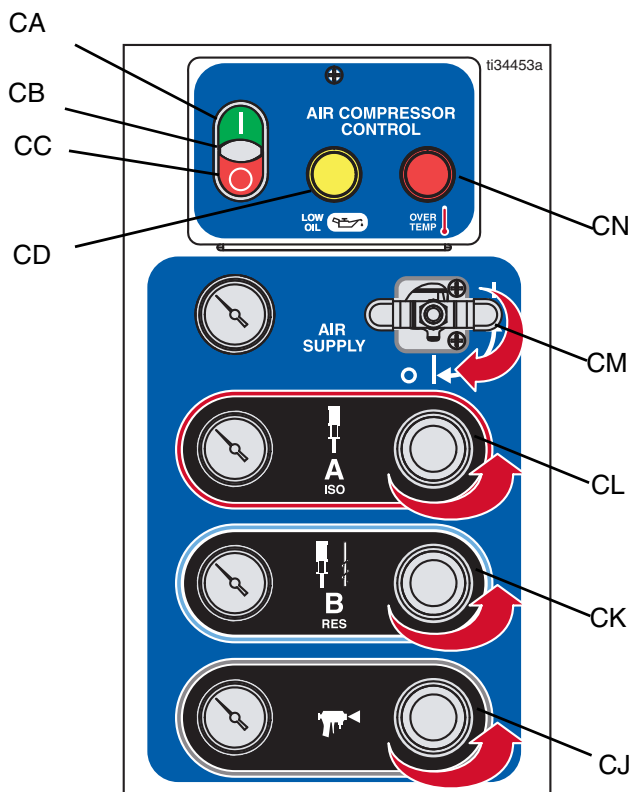

FIG. 24: Air Compressor Control Panel

9. Start the air compressor. Press the ON button (CA) on the air compressor control panel.

NOTE: As part of normal operation, the yellow Low Oil light (CD) may illuminate for up to 30 seconds during startup. The red Over Temp light (CN) may illuminate for up to 1 second.

NOTE: While the air compressor is on, the white light of the air compressor power indicator (CB) will illuminate.

NOTE: When the engine starts, the air compressor ON button (CA) is disabled for approximately 15 seconds. The air compressor cannot be started until the wait period expires.

10. Start the air dryer (U) by toggling the air dryer power switch to ON. The amber light will illuminate after approximately five minutes.

11. Open the main air supply valve (CM) on the air control panel.

NOTE: Before supplying air to the air control panel, verify that the transfer pump needle valves and the agitator air inlet valve are closed.

12. Adjust the air regulators to the desired pressure. See your transfer pump, agitator, and gun manuals for air supply pressure requirements.

NOTE: The regulator adjustment knobs can be pressed inwards to lock the regulator set point.

13. Load the system with ISO (A-side) and resin (B-side) using the transfer pumps.

- a. Check that all **Installation** steps are complete. See page 18.
- b. If an agitator is installed, open the agitator air inlet valve to start agitation.
- c. If desired, refer to your Reactor 2 proportioner manual to circulate fluid through the system or heated hose.
- d. To start the transfer pumps, open the needle valve supplied with the transfer pumps.
- e. Open the A and B inlet filter screen ball valves.

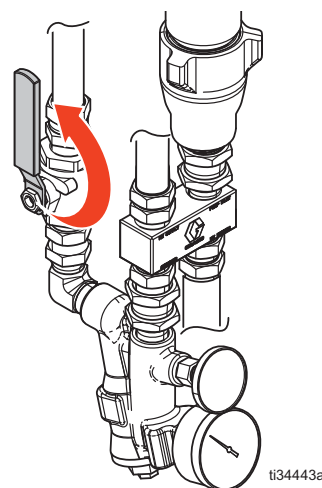





FIG. 25: Fluid Inlet Filter

- f. Open the A and B heat exchanger inlet valves (HX-A INLET, HX-B INLET).

- g. Check for leaks at all A and B fluid connections.

				
<p>Cross-contamination can result in cured material in fluid lines, which could cause serious injury or equipment damage. To prevent cross-contamination:</p> <ul style="list-style-type: none">• Never interchange component A and component B wetted parts.• Never use solvent on one side if it has been contaminated from the other side. <p>Always provide two grounded waste containers to keep component A and component B fluids separate.</p>				

14. Wait for the engine coolant to reach the operating temperature range. When the coolant reaches the operating temperature range, the Integrated PowerStation is ready for normal operation.

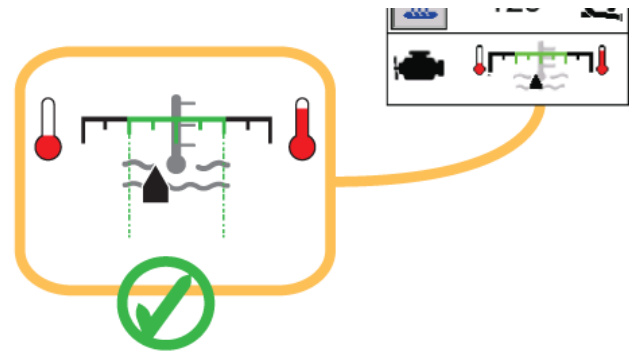



FIG. 26: Operating Temperature Range

NOTE: When the engine reaches operating temperature, the black arrow will be within the green area of the temperature bar. When operating temperature is reached, the radiator fan will cycle on and off to maintain proper engine temperature.

First Time Startup

1. Complete **Operation** steps 1-7. See page 32.
2. Turn on circuit breakers for the following components:
 - Reactor 2 proportioner
 - Heat exchange coolant pump
 - Air dryer
 - Auxiliary circuit breakers (if applicable)

NOTE: The heat exchange coolant pump circuit breaker is locked in the ON position.

3. Check the software version of your Reactor 2.
 - a. Turn the Reactor 2 main power switch to on.
 - b. Enter the Setup Mode on the ADM using the lock button .
 - c. Navigate to Advanced Screen 4.
 - d. Verify that the software version is 3.XX.XXX or newer.

NOTE: If the software is older than version 3.XX.XXX, the Reactor 2 must be updated to operate with the Integrated PowerStation. See **Update Reactor 2 Software**, page 36.

4. Once the software update is complete, press the on/off button  on the ADM.
5. If the **Connect Air Lines** procedure (page 28) is complete, the ADM will detect the new Load Center 2 (LC2) board on the Integrated PowerStation. For normal operation, select YES to connect to the Integrated PowerStation and enable Integrated Mode.

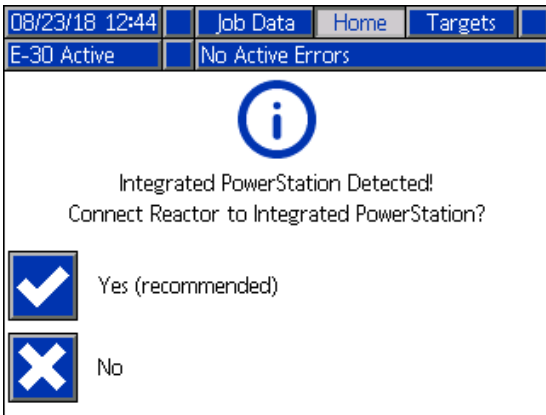



FIG. 27: Integrated PowerStation Detected

NOTE: When “YES” is selected, the system will restart and the Reactor 2 system type will update to indicate that the Integrated Mode is active. The Reactor 2 system type can be found in the upper left-hand corner of the display. When the Integrated Mode is enabled, the system type is followed by “i”. For example, E-30i, E-XP2i, H-30i, or H-XP2i.

NOTE: Some troubleshooting procedures may require you to disable the Reactor 2 Integrated Mode. The Integrated Mode can be enabled or disabled using the ADM setup screens. See FIG. 28.

6. To customize the primary (boost) heat settings:
 - a. Enter the Setup Mode on the ADM using the lock button .
 - b. Navigate to System Screen 2.

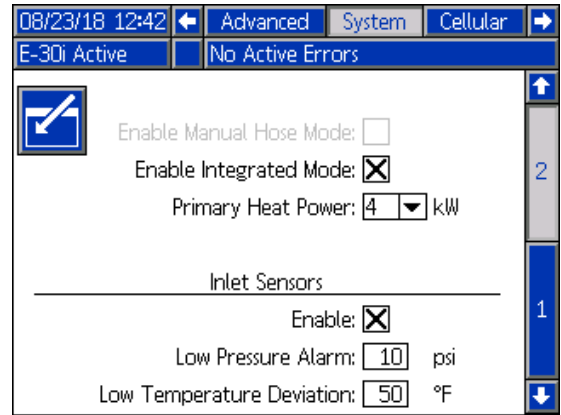



FIG. 28: System Screen 2

- c. If desired, adjust the amount of power supplied to the Reactor 2 primary heater blocks.

Primary Heat Power Level	Purpose
0 kW	Troubleshooting only. This setting disables alarms related to primary heater blocks.
2 kW	Provides the system with additional auxiliary power and provides the Reactor 2 primary heater blocks with minimal maintenance heat.
4 kW	Normal operation (default heat setting).

- d. Return to the Run Mode home screen using the lock button .

7. Complete **Operation** steps 8-14. See page 32.

Update Reactor 2 Software

When software is updated on the Reactor 2 ADM (Advanced Display Module), the software is then automatically updated on all connected GCA (Graco Control Architecture) components. Status screens indicate the progress of the software update.

1. Turn the Reactor 2 proportioner main power switch to OFF.
2. Remove the ADM from the bracket.
3. Remove the token access panel on the back of the ADM.
4. Firmly insert the software upgrade token (supplied) into the ADM slot.

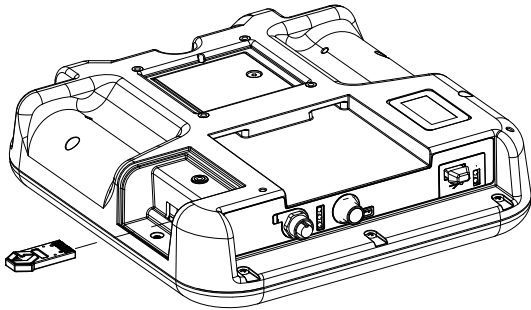

FIG. 29: Insert the Software Token

NOTE: There is no preferred orientation of the token.

5. Install the ADM into the bracket.
6. Turn the Reactor 2 proportioner main power switch to ON.

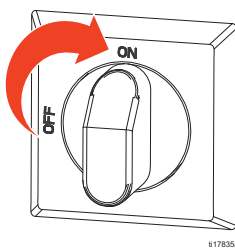

FIG. 30: Proportioner Main Power Switch

NOTICE

Status screens indicate the progress of the software update. To prevent corruption of the software, do not remove the token until the status screen disappears.

NOTE: When the ADM turns on, you will see the following screens:

<p>First:</p> <p>Software is checking which GCA modules will take the available updates.</p>	
<p>Second:</p> <p>Status of the update with the approximate time until completion.</p>	
<p>Third:</p> <p>Updates are complete. Icon indicates update success/failure.</p>	

Icon	Description
	Update successful
	Update unsuccessful
	Update complete, no changes necessary.
	Update was successful/complete, but one or more GCA modules did not have a CAN boot-loader, so software was not updated on that module.

7. Remove the software token.
8. Replace the token access panel.
9. Press to continue to the operation screens.

Fluid Circulation

Refer to your Reactor 2 proportioner manual to set up circulation through the Reactor or the gun manifold.

Pressure Relief Procedure



Follow the Pressure Relief Procedure whenever you see this symbol.

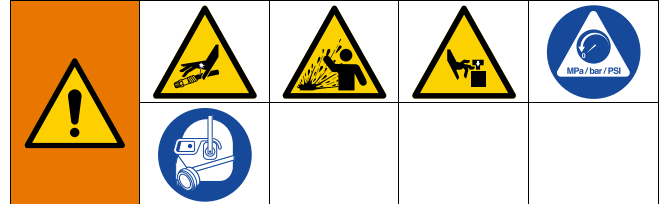

This equipment stays pressurized until pressure is manually relieved. To help prevent serious injury from pressurized fluid, such as skin injection, splashing fluid and moving parts, follow the Pressure Relief Procedure when you stop spraying and before cleaning, checking, or servicing the equipment.

1. Follow the Pressure Relief Procedure in your Reactor 2 proportioner manual.
2. Turn the air compressor OFF.
3. Turn the main air shutoff valve to OFF.
4. Verify that all pressure gauges indicate 0 psi.
5. If pressure gauges do not indicate 0 psi, repeat steps 1-5.

Shutdown

Immediate Shutdown

NOTICE
To avoid system damage, follow the daily shutdown procedure.

For immediate shutdown, press  (STOP) on the engine display.

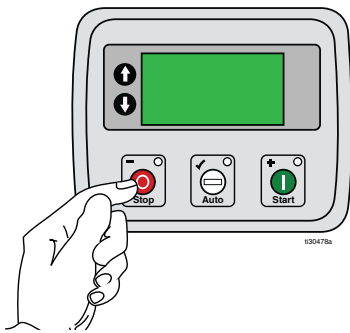

FIG. 31

Daily Shutdown



NOTICE
Proper system setup, startup, and shutdown procedures are critical to electrical equipment reliability. The following procedures ensure steady voltage. Failure to follow these procedures will cause voltage fluctuations that can damage electrical equipment and void the warranty.

1. Follow your Reactor 2 proportioner shutdown procedure.
2. Follow the **Pressure Relief Procedure**, page 37.
3. Switch off the main 90 Amp circuit breaker on the alternator.

NOTICE
To avoid damage to system or engine turbocharger, allow five minutes of idle time for engine temperatures to stabilize before turning off the engine.

4. Press  (STOP) on the engine display to turn off the engine.
5. Close the A-side and B-side inlet strainer ball valves.

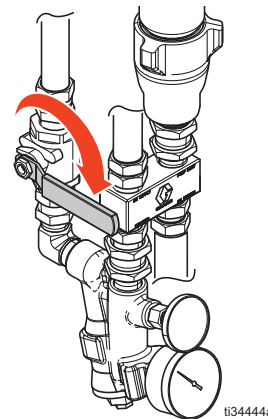

FIG. 32: Close Inlet Strainer Ball Valves

6. Engage the gun piston safety locks.

Technical Specifications

Integrated PowerStation		
	US	Metric
Maximum fluid inlet working pressure	300 psi	2.07 MPa, 20.7 bar
Maximum air outlet pressure	150 psi	1.03 MPa, 10.3 bar
Maximum ambient temperature	120°F	49°C
Minimum ambient temperature	20°F	-7°C
Auxiliary Power Availability*		
979200 Maintenance heat (2 kW)†	10.6 kVA (10.6 kW at 1.0 pf) 44 A at 240 Vac 88 A at 120 Vac	
979200 Default heat setting (4 kW)	9.1 kVA (9.1 kW at 1.0 pf) 38 A at 240 Vac 76 A at 120 Vac	
979201, 979202 Maintenance heat (2 kW)†	10.1 kVA (10.1 kW at 1.0 pf) 42 A at 240 Vac 82 A at 120 Vac	
979201, 979202 Default heat setting (4 kW)	8.6 kVA (8.6 kW at 1.0 pf) 36 A at 240 Vac 72 A at 120 Vac	
Inlet/Outlet Sizes		
Fluid inlet size	3/4 in. npt(m)	
Fluid outlet size	3/4 in. npt(m)	
Noise (dBa)		
Sound pressure (operator level)	91 dBa @ 70 psi (0.48 MPa, 4.8 bar)	
Sound power	109 dBa @ 70 psi (0.48 MPa, 4.8 bar)	
<i>Sound pressure measured 3.28 feet (1.0 meter) from equipment.</i>		
<i>Sound power measured per ISO-3744.</i>		
Weight		
979200 (no air compressor model)	1690 lb	767 kg
979201 (20 cfm compressor model)	1820 lb	826 kg
979202 (35 cfm compressor model)	1900 lb	862 kg
Wetted Parts		
Material	Nickel, stainless steel, zinc-plated carbon steel, brass, PTFE	

Integrated PowerStation

Notes

* The amount of auxiliary power available is based on the following system configuration: an Integrated PowerStation system installed with a compatible Reactor 2 proportioner operating at maximum capabilities, with 310 ft (94 m) of heated hose. The auxiliary power availability assumes the system is in operation at an altitude below 3300 ft (1 km) and at a maximum ambient temperature of 104°F (40°C). The auxiliary power of models 979201 and 979202 includes the air dryer power draw.

Additional auxiliary power can be reclaimed by reducing the length of heated hose. For every 50 ft (15 m) of hose length removed, an additional 2-3 Amps (at 240 Vac) are available.

Available auxiliary power may be reduced by:

- Operating the system at altitudes higher than 3300 ft (1 km). Refer to 240 Vac alternator documentation for derating information.
- Operating the system at system ambient temperatures higher than 104°F (40°C). Refer to 240 Vac alternator documentation for derating information.
- Operating auxiliary loads with a power factor less than 1.0 on the system. Motors and other inductive loads inherently present a power factor less than 1.0.

† Maintenance heat is the minimum Reactor 2 primary heater setting required for standard operation. Only disable the primary heaters as a temporary measure or for troubleshooting.

All trademarks or registered trademarks are the property of their respective owners.

California Proposition 65

 **WARNING:** This product can expose you to chemicals known to the State of California to cause cancer and birth defects or other reproductive harm. For more information, go to www.P65warnings.ca.gov.

 **WARNING:** Breathing diesel engine exhaust exposes you to chemicals known to the State of California to cause cancer and birth defects or other reproductive harm.

- Always start and operate the engine in a well-ventilated area.
- If in an enclosed area, vent the exhaust to the outside.
- Do not modify or tamper with the exhaust system.
- Do not idle the engine except as necessary.

For more information, go to www.P65warnings.ca.gov/diesel.

Graco Extended Warranty

Graco warrants all equipment referenced in this document which is manufactured by Graco and bearing its name to be free from defects in material and workmanship on the date of sale to the original purchaser for use. With the exception of any special, extended, or limited warranty published by Graco, Graco will, for a period of twelve months from the date of sale, repair or replace any part of the equipment determined by Graco to be defective. This warranty applies only when the equipment is installed, operated and maintained in accordance with Graco's written recommendations.

Part	Description	Warranty Period
25D410	Load Center 2	36 Months (3 Years)
	All Other Parts	12 Months

This warranty does not cover, and Graco shall not be liable for general wear and tear, or any malfunction, damage or wear caused by faulty installation, misapplication, abrasion, corrosion, inadequate or improper maintenance, negligence, accident, tampering, or substitution of non-Graco component parts. Nor shall Graco be liable for malfunction, damage or wear caused by the incompatibility of Graco equipment with structures, accessories, equipment or materials not supplied by Graco, or the improper design, manufacture, installation, operation or maintenance of structures, accessories, equipment or materials not supplied by Graco.

This warranty is conditioned upon the prepaid return of the equipment claimed to be defective to an authorized Graco distributor for verification of the claimed defect. If the claimed defect is verified, Graco will repair or replace free of charge any defective parts. The equipment will be returned to the original purchaser transportation prepaid. If inspection of the equipment does not disclose any defect in material or workmanship, repairs will be made at a reasonable charge, which charges may include the costs of parts, labor, and transportation.

THIS WARRANTY IS EXCLUSIVE, AND IS IN LIEU OF ANY OTHER WARRANTIES, EXPRESS OR IMPLIED, INCLUDING BUT NOT LIMITED TO WARRANTY OF MERCHANTABILITY OR WARRANTY OF FITNESS FOR A PARTICULAR PURPOSE.

Graco's sole obligation and buyer's sole remedy for any breach of warranty shall be as set forth above. The buyer agrees that no other remedy (including, but not limited to, incidental or consequential damages for lost profits, lost sales, injury to person or property, or any other incidental or consequential loss) shall be available. Any action for breach of warranty must be brought within two (2) years of the date of sale.

GRACO MAKES NO WARRANTY, AND DISCLAIMS ALL IMPLIED WARRANTIES OF MERCHANTABILITY AND FITNESS FOR A PARTICULAR PURPOSE, IN CONNECTION WITH ACCESSORIES, EQUIPMENT, MATERIALS OR COMPONENTS SOLD BUT NOT MANUFACTURED BY GRACO. These items sold, but not manufactured by Graco (such as electric motors, switches, hose, etc.), are subject to the warranty, if any, of their manufacturer. Graco will provide purchaser with reasonable assistance in making any claim for breach of these warranties.

In no event will Graco be liable for indirect, incidental, special or consequential damages resulting from Graco supplying equipment hereunder, or the furnishing, performance, or use of any products or other goods sold hereto, whether due to a breach of contract, breach of warranty, the negligence of Graco, or otherwise.

FOR GRACO CANADA CUSTOMERS

The Parties acknowledge that they have required that the present document, as well as all documents, notices and legal proceedings entered into, given or instituted pursuant hereto or relating directly or indirectly hereto, be drawn up in English. Les parties reconnaissent avoir convenu que la rédaction du présente document sera en Anglais, ainsi que tous documents, avis et procédures judiciaires exécutés, donnés ou intentés, à la suite de ou en rapport, directement ou indirectement, avec les procédures concernées.

Graco Information

For the latest information about Graco products, visit www.graco.com.

For patent information, see www.graco.com/patents.

TO PLACE AN ORDER, contact your Graco distributor or call to identify the nearest distributor.

Phone: 612-623-6921 or **Toll Free:** 1-800-328-0211 **Fax:** 612-378-3505

All written and visual data contained in this document reflects the latest product information available at the time of publication. Graco reserves the right to make changes at any time without notice.

Original instructions. This manual contains English. MM 3A6335

Graco Headquarters: Minneapolis

International Offices: Belgium, China, Japan, Korea

GRACO INC. AND SUBSIDIARIES • P.O. BOX 1441 • MINNEAPOLIS MN 55440-1441 • USA
Copyright 2018, Graco Inc. All Graco manufacturing locations are registered to ISO 9001.

www.graco.com
Revision A, November 2018