

Fluid Section Repair Kit D05XXX

406430B

For Husky® 515 and Husky® 716 Air-Operated Diaphragm Pumps

ENG



Important Safety Instructions

Read all warnings and instructions in Husky pump manual 308981. Save all instructions.

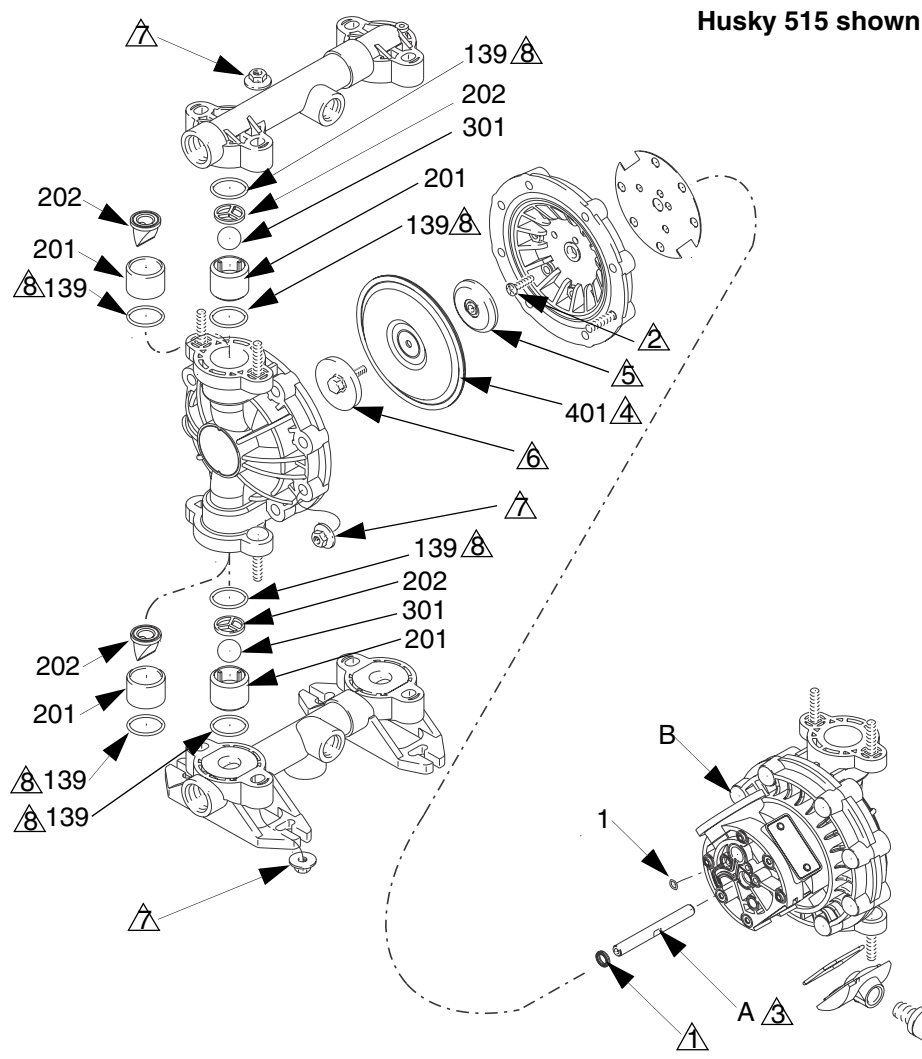

Husky 515 shown

- 1 Install with lips facing out of center housing (B).
- 2 Torque to 25 to 35 in-lb (2.8 to 4.0 N•m).
- 3 Apply grease.
- 4 The words "AIR SIDE" on diaphragm must face toward diaphragm shaft (A).
- 5 Flat side of air-side diaphragm plate must face toward diaphragm shaft (A).
- 6 Apply medium-strength (blue) Loctite® or equivalent to threads, and torque to 80 to 90 in-lb (9 to 10 N•m) at 100 rpm maximum.
- 7 Torque to 80 to 90 in-lb (9 to 10 N•m).
- 8 Use encapsulated o-rings (clear outer part).

NOTE: Reference numbers in this drawing correspond to reference numbers in manual 308981.

See reverse for Husky 716 pumps.

9100A

Husky 716 shown

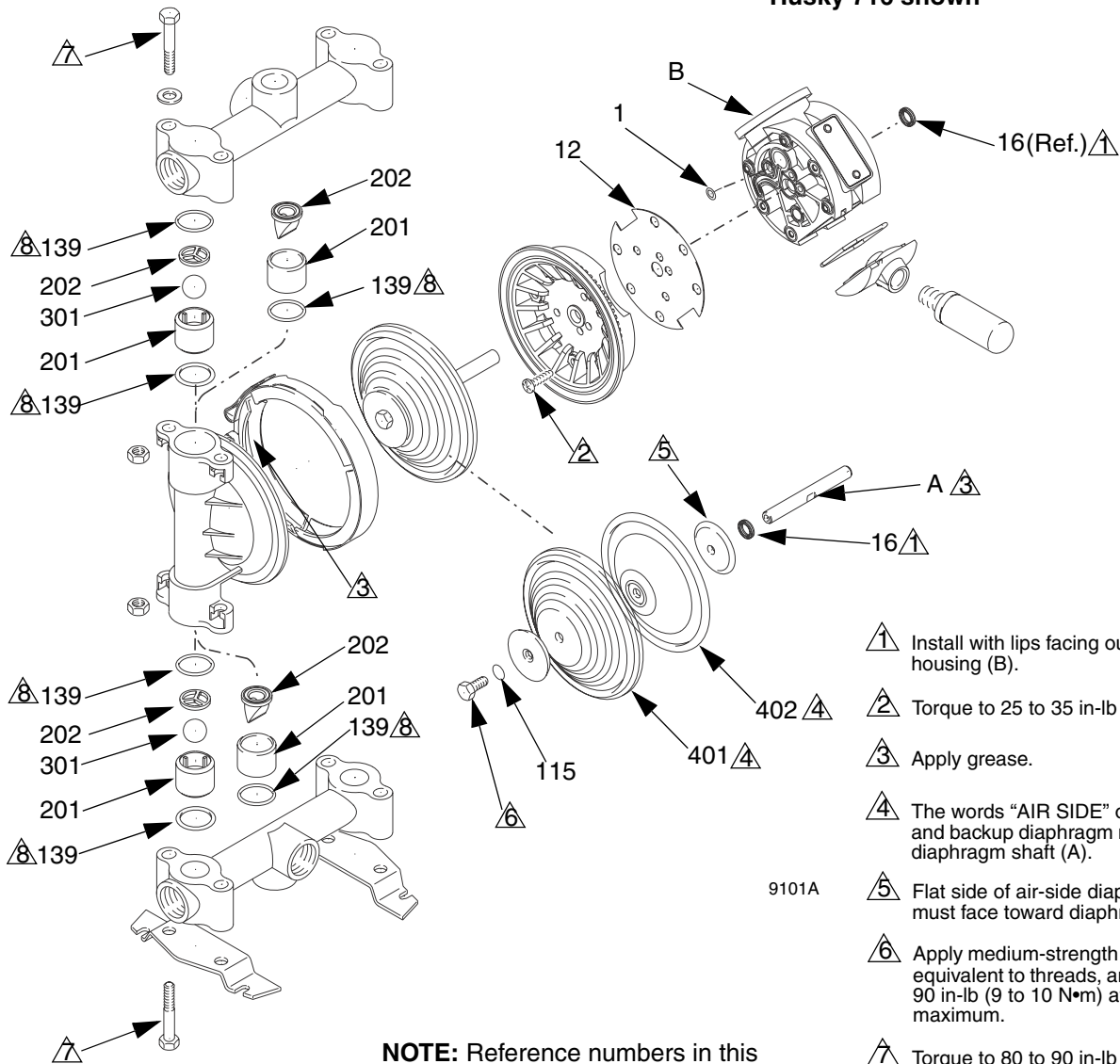

NOTE: Reference numbers in this drawing correspond to reference numbers in manual 308981.

- ① Install with lips facing out of center housing (B).
- ② Torque to 25 to 35 in-lb (2.8 to 4.0 N•m).
- ③ Apply grease.
- ④ The words "AIR SIDE" on diaphragm and backup diaphragm must face toward diaphragm shaft (A).
- 9101A ⑤ Flat side of air-side diaphragm plate must face toward diaphragm shaft (A).
- ⑥ Apply medium-strength (blue) Loctite® or equivalent to threads, and torque to 80 to 90 in-lb (9 to 10 N•m) at 100 rpm maximum.
- ⑦ Torque to 80 to 90 in-lb (9 to 10 N•m).
- ⑧ Use solid white o-rings.

All written and visual data contained in this document reflects the latest product information available at the time of publication. Graco reserves the right to make changes at any time without notice.

Original instructions. This manual contains English. MM 406430

Graco Headquarters: Minneapolis

International Offices: Belgium, China, Japan, Korea

GRACO INC. P.O. BOX 1441 MINNEAPOLIS, MN 55440-1441

Copyright 2009, Graco Inc. is registered to ISO 9001

www.graco.com

Revised 03/2011