

## Fluid Outlet Filter

307273ZAE  
EN

*For filtering of finishing materials. For professional use only.*



### Important Safety Instructions

Read all warnings and instructions in this manual. Save these instructions.

See page 2 for maximum working pressures.

## Table of Contents

List of Models .....	2
Symbols .....	3
Warnings .....	3
Installation .....	5
Maintenance .....	6
Parts .....	7
Accessories .....	19
Technical Data .....	21
Warranty .....	22
Graco Information .....	22

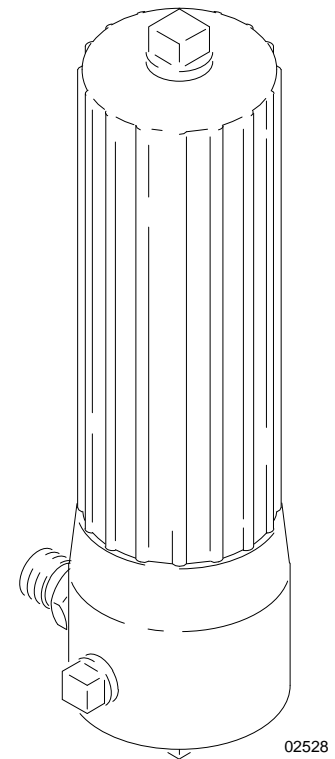

**Model 214570 shown**

# List of Models

Part No.	Series	Description	Outlet Size	Maximum Fluid Working Pressure
214570	B	Aluminum bowl, polyethylene support	1/4 npt	3000 psi (21 MPa, 210 bar)
236789	A	Aluminum bowl, polyethylene support	3/8 npt	3000 psi (21 MPa, 210 bar)
237481	A	Aluminum bowl, polyethylene support	3/8 npt	3000 psi (21 MPa, 210 bar)
239286	A	Aluminum bowl, polyethylene support	1/4 npt	3000 psi (21 MPa, 210 bar)
218029	B	Carbon steel bowl, polyethylene support	1/4 npt	5000 psi (35 MPa, 350 bar)
239060	A	Carbon steel bowl, polyethylene support	1/4 npt	5000 psi (35 MPa, 350 bar)
24F620	A	Carbon steel bowl, polyethylene support	1/4 npt	5000 psi (35 MPa, 350 bar)
239244	A	Carbon steel bowl, polyethylene support	1/4 npt	5000 psi (35 MPa, 350 bar)
241317	B	Carbon steel bowl, polyethylene support	1/4 npt	5000 psi (35 MPa, 350 bar)
239962	A	Carbon steel bowl, polyethylene support	1/4 npt	5000 psi (35 MPa, 350 bar)
239964	A	Carbon steel bowl, polyethylene support	1/4 npt	5000 psi (35 MPa, 350 bar)
240169	A	Carbon steel bowl, polyethylene support	1/4 npt	5000 psi (35 MPa, 350 bar)
24T914	A	Carbon steel bowl, polyethylene support	1/4 npt	5000 psi (35 MPa, 350 bar)
241107	A	Carbon steel bowl, polyethylene support	3/8 npt	5000 psi (35 MPa, 350 bar)
223160	B	Stainless steel bowl, polyethylene support	1/4 npt	5000 psi (35 MPa, 350 bar)
24A587	B	Stainless steel bowl, polyethylene support	1/4 npt	5000 psi (35 MPa, 350 bar)
239063	A	Stainless steel bowl, polyethylene support	1/4 npt	5000 psi (35 MPa, 350 bar)
239300	A	Stainless steel bowl, polyethylene support	1/4 npt	5000 psi (35 MPa, 350 bar)
239800	A	Stainless steel bowl, polyethylene support	1/4 npt	5000 psi (35 MPa, 350 bar)
239961	A	Stainless steel bowl, polyethylene support	1/4 npt	5000 psi (35 MPa, 350 bar)
239963	A	Stainless steel bowl, polyethylene support	1/4 npt	4000 psi (28 MPa, 280 bar)
240170	A	Stainless steel bowl, polyethylene support	1/4 npt	5000 psi (35 MPa, 350 bar)
238782	A	Stainless steel bowl, polyethylene support	3/8 npt	5000 psi (35 MPa, 350 bar)
248851	A	Stainless steel bowl, polyethylene support	3/8 npt	5000 psi (35 MPa, 350 bar)
240183	A	Stainless steel bowl, polyethylene support	1/2 npt	5000 psi (35 MPa, 350 bar)
24F658	A	Stainless steel bowl, polyethylene support	1/2 npt	5000 psi (35 MPa, 350 bar)
24U609	A	Stainless steel bowl, polyethylene support	1/2 npt	5000 psi (35 MPa, 350 bar)
24V925	A	Carbon steel bowl, polyethylene support	1/4 npt	5000 psi (35 MPa, 350 bar)
26A069	A	316 sst bowl, polyethylene support	1/4 npt	5000 psi (35 MPa, 350 bar)

# Symbols

## Warning Symbol



This symbol alerts you to the possibility of serious injury or death if you do not follow the instructions.

## Caution Symbol



This symbol alerts you to the possibility of damage to or destruction of equipment if you do not follow the instructions.

## WARNING



INSTRUCTIONS

### EQUIPMENT MISUSE HAZARD

Equipment misuse can cause the equipment to rupture or malfunction and result in serious injury.

- This equipment is for professional use only.
- Read all instruction manuals, tags, and labels before operating the equipment.
- Use the equipment only for its intended purpose. If you are uncertain about usage, call your Graco distributor.
- Do not alter or modify this equipment. Use only genuine Graco parts and accessories.
- Check equipment daily. Repair or replace worn or damaged parts immediately.
- Do not exceed the maximum working pressure of the lowest rated system component. Refer to the **Technical Data** on page 21 for the maximum working pressure of this equipment.
- Use fluids and solvents which are compatible with the equipment wetted parts. Refer to the **Technical Data** section of all equipment manuals. Read the fluid and solvent manufacturer's warnings.
- Never use 1,1, 1-trichloroethane, methylene chloride, other halogenated hydrocarbon solvents or fluids containing such solvents in pressurized aluminum equipment. Such use could result in a chemical reaction, with the possibility of explosion.
- Comply with all applicable local, state, and national fire, electrical, and safety regulations.

# WARNING

## SKIN INJECTION HAZARD



Spray from the gun, hose leaks, or ruptured components can inject fluid into your body and cause extremely serious injury, including the need for amputation. Fluid splashed in the eyes or on the skin can also cause serious injury.



- Fluid injected into the skin might look like just a cut, but it is a serious injury. **Get immediate surgical treatment.**
- Do not point the gun at anyone or at any part of the body.
- Do not put your hand or fingers over the spray tip.
- Do not stop or deflect leaks with your hand, body, glove or rag.
- Follow the **Pressure Relief Procedure** on page 5 whenever you: are instructed to relieve pressure; stop spraying; clean, check, or service the equipment; and install or clean the spray tip.
- Tighten all fluid connections before operating the equipment.
- Check the hoses, tubes, and couplings daily. Replace worn, damaged, or loose parts immediately. Permanently coupled hoses cannot be repaired; replace the entire hose.



## TOXIC FLUID HAZARD

Hazardous fluid or toxic fumes can cause serious injury or death if splashed in the eyes or on the skin, inhaled, or swallowed.

- Know the specific hazards of the fluid you are using.
- Store hazardous fluid in an approved container. Dispose of hazardous fluid according to all local, state and national guidelines.
- Always wear protective eyewear, gloves, clothing and respirator as recommended by the fluid and solvent manufacturer.

# Installation

Install a suitable adapter in the 3/8 npt filter inlet (Model 240183 has a 1/2 npt inlet). Then install the filter downstream from the pump fluid outlet.

Install a suitable adapter in the filter outlet. Models 236789, 237480, 237481, 238782, 241107, and 248851 have a 3/8 npt outlet, and Models 240183, 24U609, and 24F658 have a 1/2 npt outlet; the others have a 1/4 npt outlet. Connect the spray hose to the filter outlet.

## Installing Filter Kit 248851 on ProMix™ Easy with HydraMix™ Pumps

1. Remove the elbow (A) from the pump outlet. Install it into the filter outlet (B). See Fig. 1.
2. Install the filter assembly onto the pump by screwing the filter elbow (5) into the pump outlet.
3. Rotate the pump and tubing to align and connect the tubing to the filter outlet.

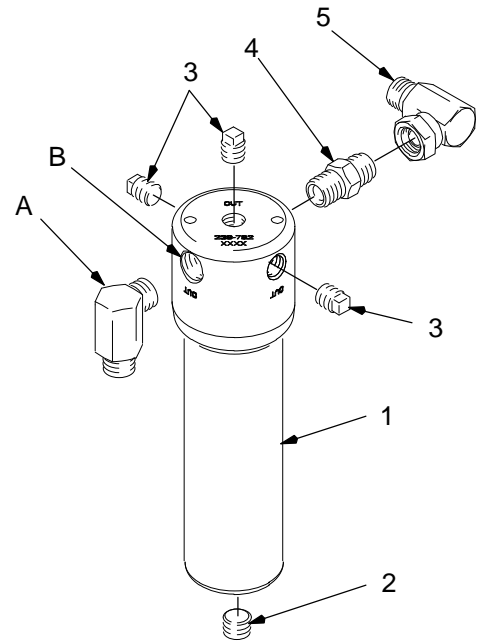

Fig. 1

TH15371A

# Operation

## Pressure Relief Procedure

**⚠ WARNING**

**SKIN INJECTION HAZARD**

The system pressure must be manually relieved to prevent the system from starting or spraying accidentally. Fluid under high pressure can be injected through the skin and cause serious injury. To reduce the risk of an injury from injection, splashing fluid, or moving parts, follow the **Pressure Relief Procedure** whenever you:

- are instructed to relieve the pressure,
- stop spraying,
- check or service any of the system equipment,
- or install or clean the spray tip.

1. Lock the gun trigger safety.
2. Turn off the power to the pump.
3. Close any bleed-type master air valves.
4. Unlock the gun trigger safety.
5. Hold a metal part of the gun firmly to the side of a grounded metal pail, and trigger the gun to relieve pressure.
6. Lock the gun trigger safety.
7. Open the system drain valve(s), having a container ready to catch the drainage.

**NOTE:** Some models are supplied with a drain valve (12). Refer to the parts list for your model.

8. Leave the drain valve(s) open until you are ready to spray again.

*If you suspect that the spray tip or hose is completely clogged, or that pressure has not been fully relieved after following the steps above, **very slowly** loosen the tip guard retaining nut or hose end coupling and relieve pressure gradually, then loosen completely. Now clear the tip or hose.*

# Maintenance

## Cleaning the Filter

Dried paint sediment can clog the filter screen and greatly reduce filtering ability. Dried paint also makes the filter difficult to remove. Clean the filter regularly; daily if needed, following the procedure below.

### ⚠ CAUTION

To avoid damaging parts, **never** force them apart. If any parts are stuck tightly together, soak them in a compatible solvent before disassembling them.

Be careful not to drop or damage the filter housing and bowl. Dirt, paint sediment, nicks or scratches may prevent the o-ring (3) from seating properly.

### ⚠ WARNING

To reduce the risk of serious injury whenever you are instructed to relieve pressure, always follow the **Pressure Relief Procedure** on page 5.

1. Relieve the pressure.
2. Carefully remove the drain plug (1) from the bottom of the filter bowl (7) to drain the fluid.

#### NOTES:

- Some models are supplied with a drain valve (12). Refer to the parts list for your model.
  - Drain plug not used with Model 241107.
3. Unscrew the bowl from the filter housing (9).
  4. Pull the screen (5) straight out of the bowl. (See **Accessories** for other available screens.)
  5. Remove the compression spring (8) from the filter bowl (7).
  6. To remove the filter support (6), gently push in on the filter support stud. Replace the filter support if the ridges are worn.
  7. Clean all parts thoroughly with a compatible solvent.
  8. Place the filter support (6) in the screen (5) so the support stud fits through the small opening in the bottom of the screen.
  9. Press fit the compression spring (8) to the bottom of the filter bowl (7).
  10. Carefully install the filter support (6) and screen (5) into the filter bowl (7).

### ⚠ CAUTION

Improper assembly of the filter support, screen and spring will prevent filtering and damage parts.

11. Replace the o-ring (3) if damaged or worn. Lubricate the o-ring with No. 2 grease. Bend it into a kidney shape, then carefully push it into the groove to avoid damaging it.
12. Lubricate the filter bowl (7) threads and screw it firmly into the housing (9).

**NOTE:** Be sure the bottom drain plug or drain valve is closed before starting the pump.

*Model 214570, 236789:* Apply PTFE tape to all non-swiveling pipe threads.

*All other models:* Apply anaerobic pipe sealant to all non-swiveling pipe threads.

**Model 214570 is shown**

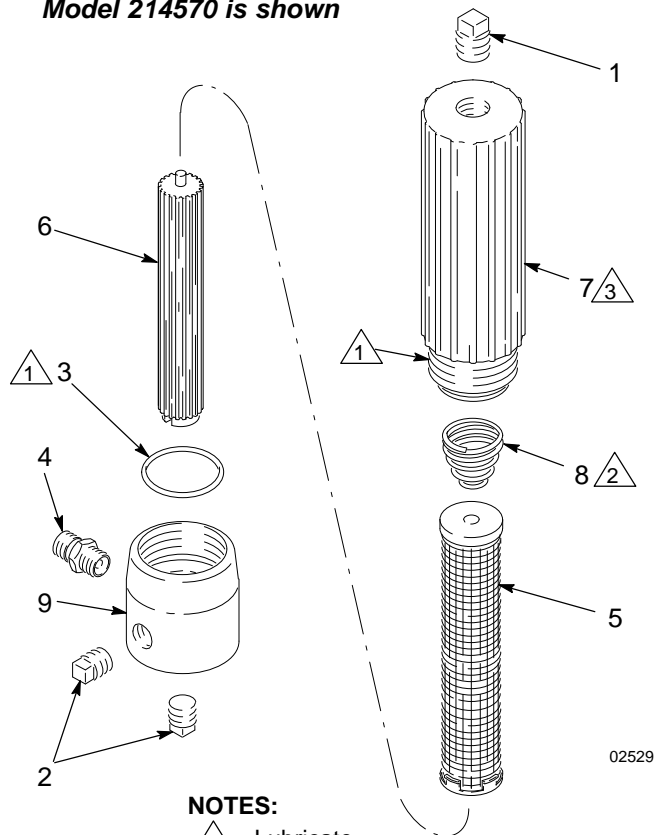

#### NOTES:

- ⚠ 1 Lubricate
- ⚠ 2 Press fit spring to bottom of bowl
- ⚠ 3 Screw bowl firmly into housing

**Fig. 2**

# Parts

## Model 214570, Series B

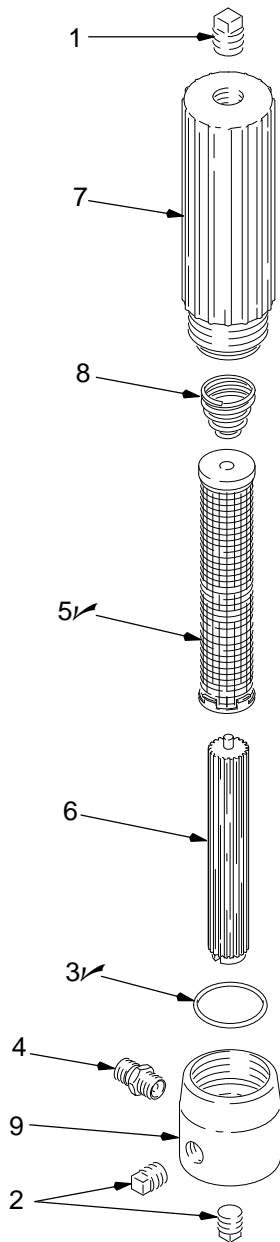

## Model 236789, Series A

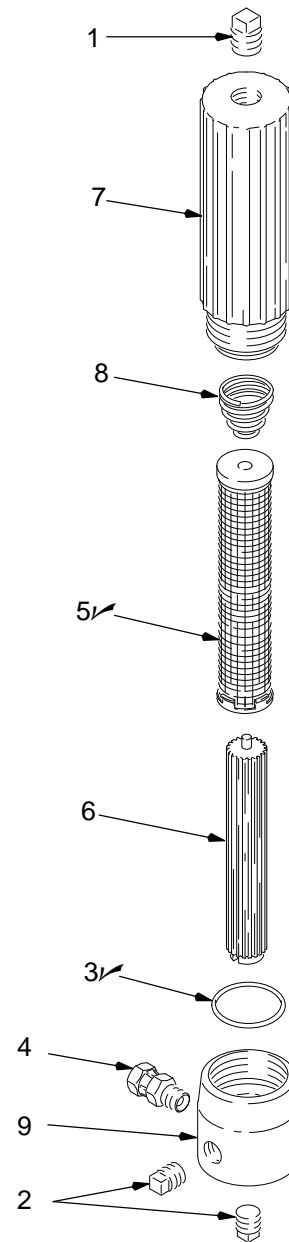

02529

Ref No.	Part No.	Description	Qty.
1	100040	PLUG; 3/8 npt; steel or iron	1
2	100509	PLUG; 1/4 npt; iron	2
3✓	104361	O-RING; PTFE	1
4	162453	NIPPLE; 1/4 npsm x 1/4 npt	1
5✓	167025	SCREEN, stainless steel; 60 mesh	1
6	186075	SUPPORT, filter; polyethylene	1
7	172831	BOWL, filter; aluminum	1
8	171941	SPRING, compression; stainless steel	1
9	171942	HOUSING, filter; carbon steel	1

✓ Keep these parts on hand to reduce down time.

Ref No.	Part No.	Description	Qty.
1	100040	PLUG; 3/8 npt; steel or iron	1
2	100509	PLUG; 1/4 npt; iron	2
3✓	104361	O-RING; PTFE	1
4	155665	SWIVEL	1
5✓	167025	SCREEN, stainless steel; 60 mesh	1
6	186075	SUPPORT, filter; polyethylene	1
7	172831	BOWL, filter; aluminum	1
8	171941	SPRING, compression; stainless steel	1
9	188562	HOUSING, filter; carbon steel	1

✓ Keep these parts on hand to reduce down time.

# Parts

Model 218029, Series B    Model 24V925, Series A  
 Model 241317, Series A    Model 24T914, Series A

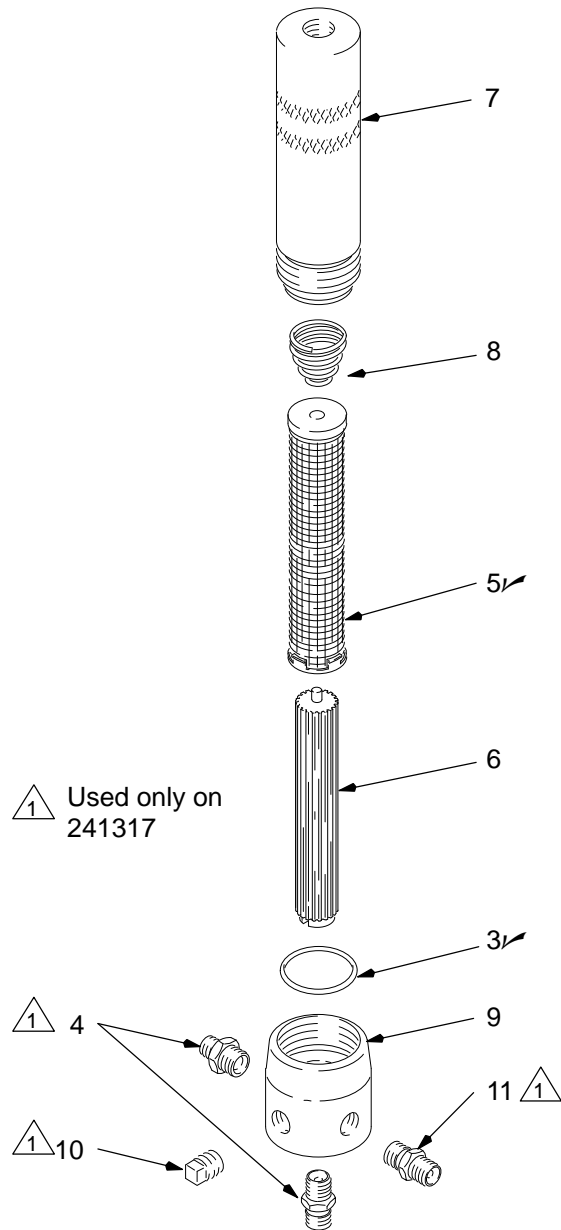

02530B

Model 223160, Series B  
 Model 24A587, Series B

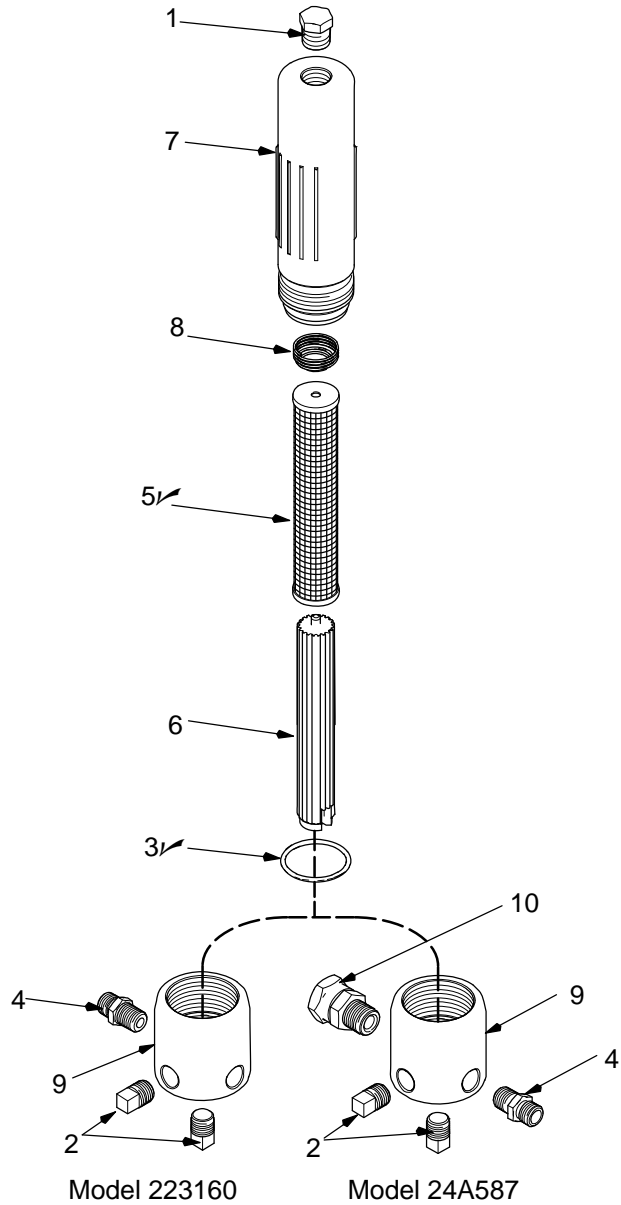

02531b

Ref.	Part No.	Description	Qty.
3✓	104361	O-RING; PTFE	1
4	162453	NIPPLE; 1/4 npsm x 1/4 npt	2
5✓	167025	SCREEN, stainless steel; 60 mesh (Models 218029 and 241317 only)	1
	167024	SCREEN, stainless steel; 30 mesh (Model 24T914 only)	1
	167026	SCREEN, stainless steel; 100 mesh (Model 24V925 only)	1
6	186075	SUPPORT, filter; polyethylene	1
7		BOWL, filter; carbon steel	1
	24C501	Model 218029 (shown)	1
	246582	Model 241317	1
	179773	Model 24T914	1
8	171941	SPRING, compression; stainless steel	1
9	171942	HOUSING, filter; carbon steel	1
10	100509	PLUG, pipe; 1/4 npt	1
11	157350	ADAPTER, 3/8 npt x 1/4 npt	1

Ref.	Part No.	Description	Qty.
110740		PLUG; 3/8 npt; stainless steel	1
2	111697	PLUG; 1/4 npt; stainless steel	2
3✓	104361	O-RING; PTFE	1
4	166846	NIPPLE; 1/4 npsm x 1/4 npt; stainless steel	1
5✓	167025	SCREEN, stainless steel; 60 mesh	1
6	186075	SUPPORT, filter; polyethylene	1
7	185632	BOWL, filter; stainless steel	1
8	171941	SPRING, compression; stainless steel	1
9	185631	HOUSING, filter; stainless steel	1
10	235208	SWIVEL, 3/8-18 npsm x 3/8-18 npt (Model 24A587)	1

✓ Keep these spare parts on hand to reduce down time.



# Parts

## Model 239800, Series A

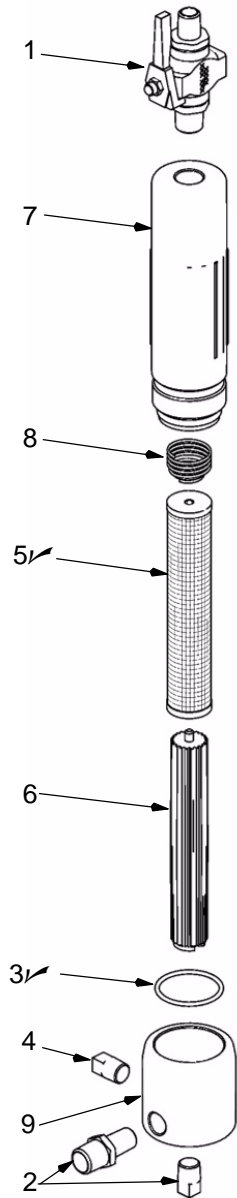

ti11574a

## Model 240183, Series A

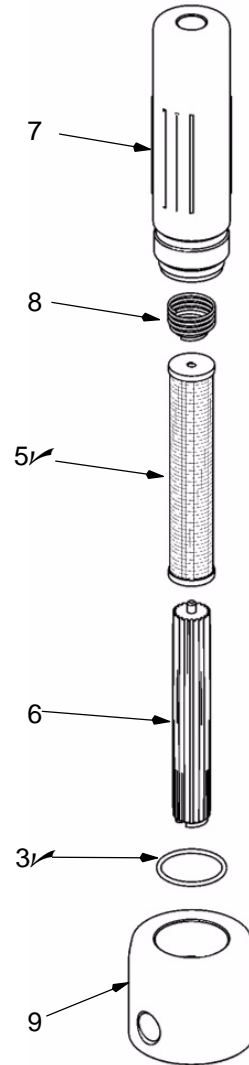

ti11575a

Ref. No.	Part No.	Description	Qty.
1	235992	VALVE, ball; 3/8 npt (mbe); stainless steel	1
2	111697	PLUG; 1/4 npt; stainless steel	2
3✓	104361	O-RING; PTFE	1
4	164856	ADAPTER; 3/8 npt x 1/4 npt (mbe); stainless steel	1
5✓	167026	SCREEN, stainless steel; 100 mesh	1
6	186075	SUPPORT, filter; polyethylene	1
7	185632	BOWL, filter; stainless steel	1
8	171941	SPRING, compression; stainless steel	1
9	185631	HOUSING, filter; stainless steel	1

✓ Keep these spare parts on hand to reduce down time.

Ref. No.	Part No.	Description	Qty.
3✓	104361	O-RING; PTFE	1
5✓	167025	SCREEN, stainless steel; 60 mesh	1
6	186075	SUPPORT, filter; polyethylene	1
7	185632	BOWL, filter; stainless steel	1
8	171941	SPRING, compression; stainless steel	1
9	192975	HOUSING, filter; stainless steel	1

✓ Keep these spare parts on hand to reduce down time.

# Parts

## Model 26A069, Series A

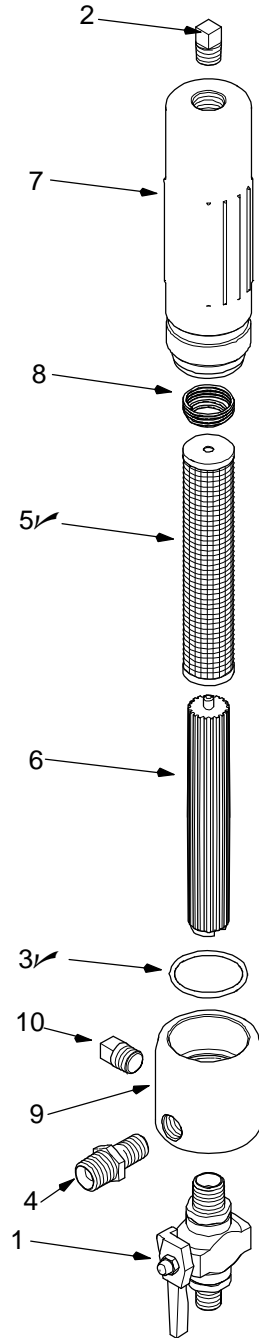

ti11574a

Ref. No.	Part No.	Description	Qty.	Ref. No.	Part No.	Description	Qty.
1	26A078	VALVE, ball; 3/8 npt (mbe); stainless steel	1	6	186075	SUPPORT, filter; polyethylene	1
2	110740	PLUG; 3/8 npt; stainless steel	1	7	17K788	BOWL, filter; stainless steel	1
3✓	104361	O-RING; PTFE	1	8	17K789	SPRING, compression; stainless steel	1
4	17K786	ADAPTER; 3/8 npt x 1/4 npt (mbe); stainless steel	1	9	17K790	HOUSING, filter; stainless steel	1
5✓	17K787	SCREEN, stainless steel; 100 mesh	1	10	101970	PLUG, 1/4npt, stainless steel	1

✓ Keep these spare parts on hand to reduce down time.

# Parts

## Model 238782, Series A

## Model 248851, Series A

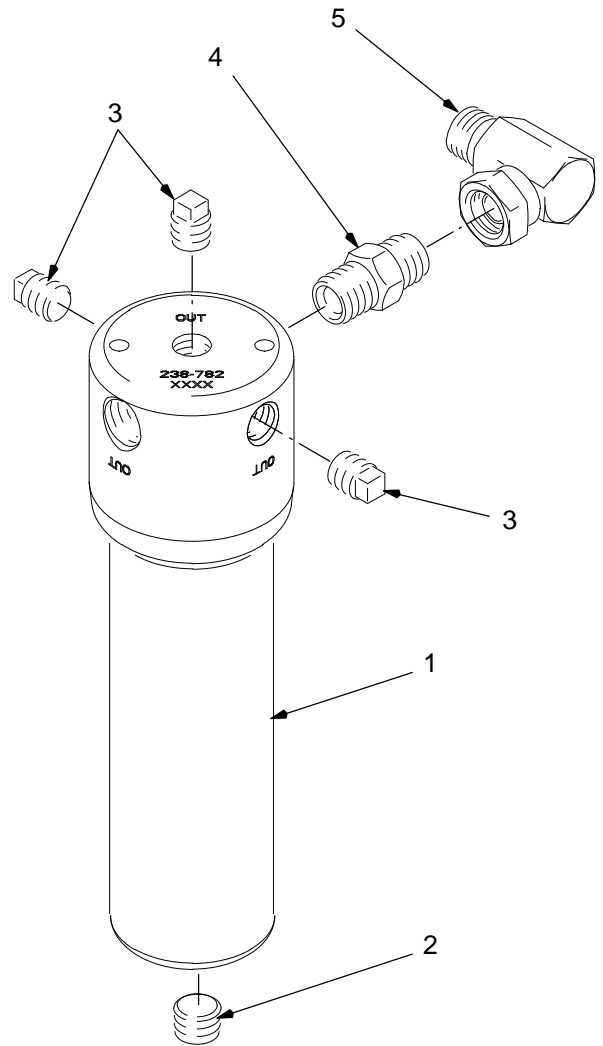
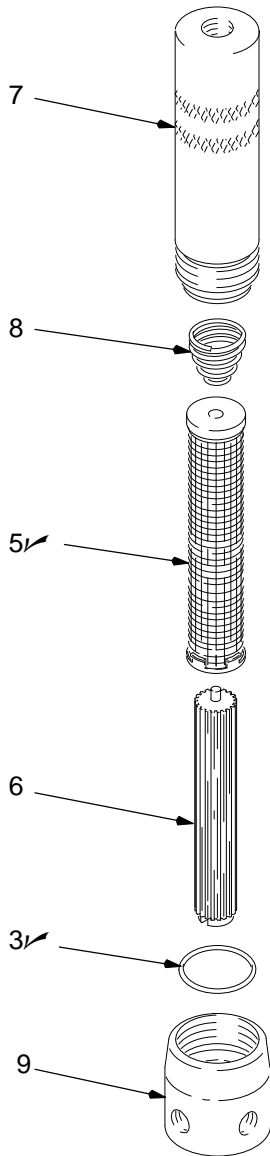

T115371A

Ref. No.	Part No.	Description	Qty.	Ref. No.	Part No.	Description	Qty.
3✓	104361	O-RING; PTFE	1	1	238782	FLUID FILTER ASSEMBLY; see parts at left	1
5✓	167024	SCREEN, stainless steel; 30 mesh	1	2	101748	PLUG; 3/8 npt; stainless steel	1
6	186075	SUPPORT, filter; polyethylene	1	3	111697	PLUG; 1/4 npt; stainless steel	3
7	196290	BOWL, filter; stainless steel	1	4	166469	NIPPLE; 3/8 npt; stainless steel	1
8	171941	SPRING, compression; stainless steel	1	5	207123	ELBOW, swivel, 90°	1
9	193331	HOUSING, filter; stainless steel	1				

✓ Keep these spare parts on hand to reduce down time.

# Parts

## Model 239060, Series A

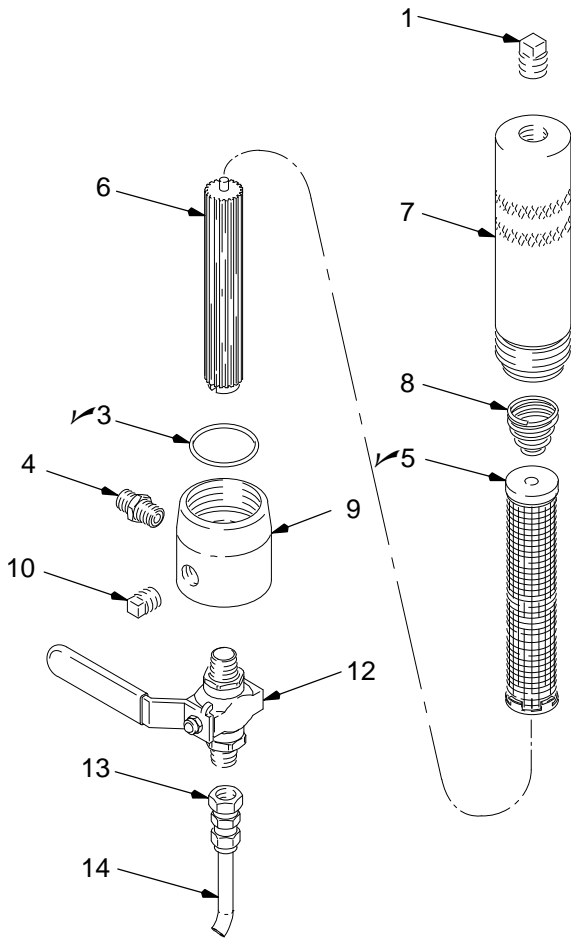

7001A

Ref. No.	Part No.	Description	Qty.
1	100040	PLUG; 3/8 npt; steel or iron	1
3✓	104361	O-RING; PTFE	1
4	162453	NIPPLE; 1/4 npsm x 1/4 npt; carbon steel	1
5✓	167025	SCREEN, stainless steel; 60 mesh	1
6	186075	SUPPORT, filter; polyethylene	1
7	24C501	BOWL, filter; carbon steel	1
8	171941	SPRING, compression; stainless steel	1
9	171942	HOUSING, filter; carbon steel	1
10	100509	PLUG, pipe; 1/4 npt	1
12	238635	VALVE, ball; 1/4 npt (mbe); carbon steel	1
13	205447	COUPLING; 1/4 npsm(f)	1
14	061132	TUBE, drain; nylon; 1/4 in. (0.6 mm) ID; 8 in. (203 mm)	1

✓ Keep these spare parts on hand to reduce down time.

## Model 239244, Series A

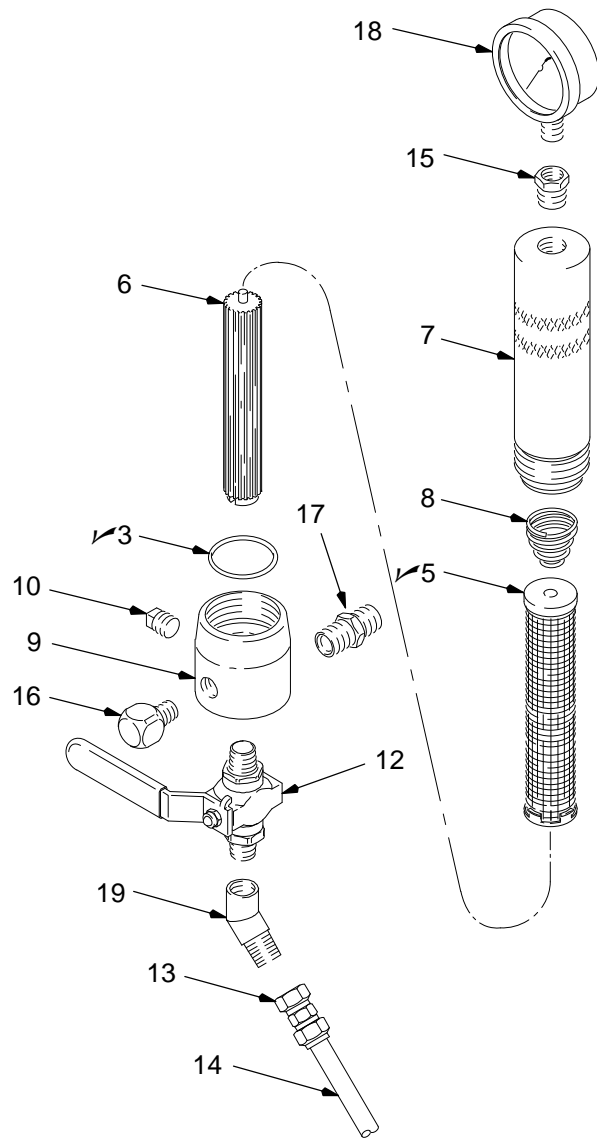

7007A

Ref. No.	Part No.	Description	Qty.
3✓	104361	O-RING; PTFE	1
5✓	167025	SCREEN, stainless steel; 60 mesh	1
6	186075	SUPPORT, filter; polyethylene	1
7	24C501	BOWL, filter; carbon steel	1
8	171941	SPRING, compression; stainless steel	1
9	171942	HOUSING, filter; carbon steel	1
10	100509	PLUG, pipe; 1/4 npt	1
12	238635	VALVE, ball; 1/4 npt (mbe); carbon steel	1
13	205447	COUPLING; 1/4 npsm(f)	1
14	061132	TUBE, drain; nylon; 1/4 in. (0.6 mm) ID; 8 in. (203 mm)	1
15	159841	BUSHING; 3/8 npt(m) x 1/4 npt(f)	1
16	100840	ELBOW, 90°; 1/4 npt (m x f); carbon steel	1
17	156849	NIPPLE; 3/8 npt; carbon steel	1
18	102814	GAUGE, pressure	1
19	113444	ELBOW, 45°; 1/4 npt (m x f); brass	1

✓ Keep these spare parts on hand to reduce down time.

# Parts

## Model 239962, Series A

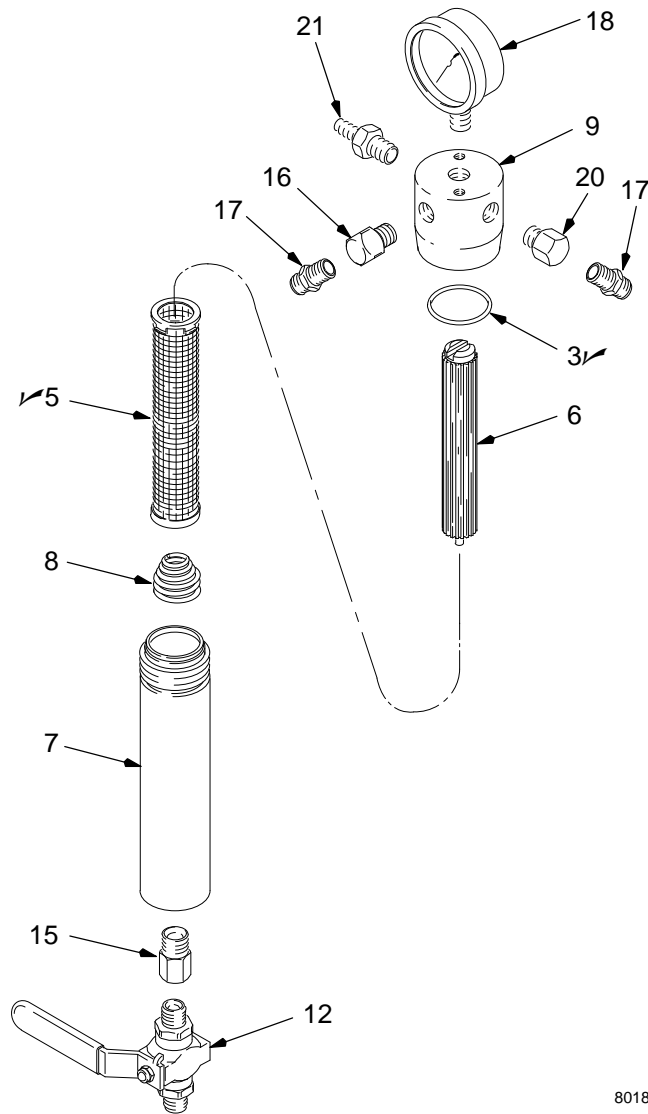

8018

Ref. No.	Part No.	Description	Qty.
3✓	104361	O-RING; PTFE	1
5✓	167025	SCREEN, stainless steel; 60 mesh	1
6	186075	SUPPORT, filter; polyethylene	1
7	24C501	BOWL, filter; carbon steel	1
8	171941	SPRING, compression; stainless steel	1
9	171942	HOUSING, filter; carbon steel	1
12	238635	VALVE, ball; 1/4 npt (mbe); carbon steel	1
15	159841	BUSHING; 3/8 npt(m) x 1/4 npt(f)	1
16	100840	ELBOW, 90°; 1/4 npt (m x f); carbon steel	1
17	162453	NIPPLE; 1/4 npt x 1/4 npsm; carbon steel	2
18	102814	GAUGE, pressure	1
20	164259	ELBOW, 90°; 3/8 npt(m) x 1/4 npt (f)	1
21	156953	STUD, mounting	1

✓ Keep these spare parts on hand to reduce down time.

## Model 239964, Series A

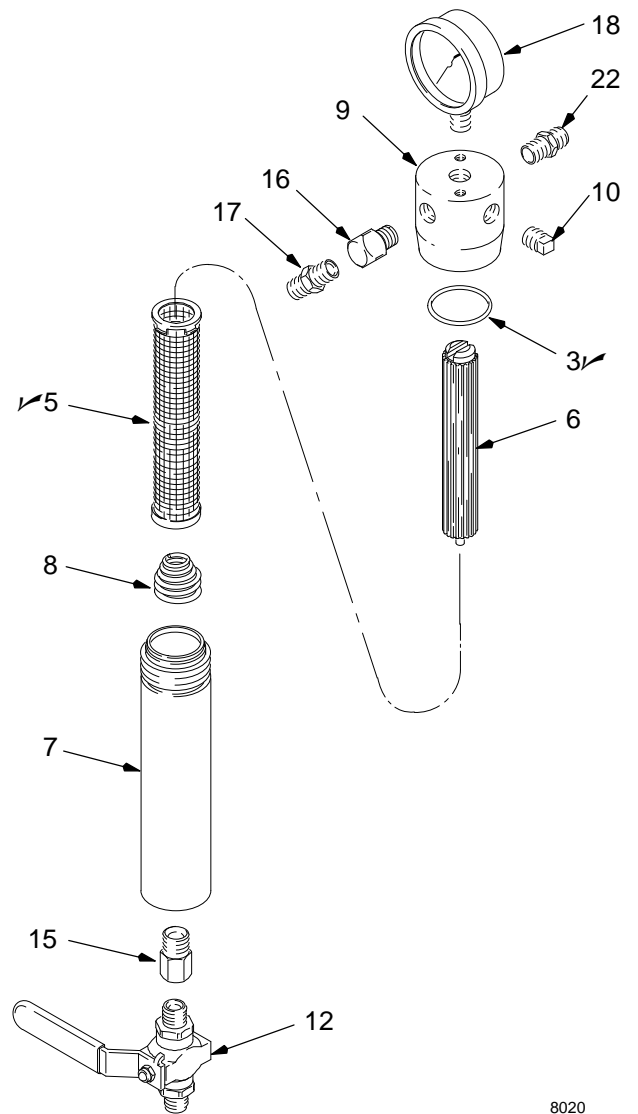

8020

Ref. No.	Part No.	Description	Qty.
3✓	104361	O-RING; PTFE	1
5✓	167025	SCREEN, stainless steel; 60 mesh	1
6	186075	SUPPORT, filter; polyethylene	1
7	24C501	BOWL, filter; carbon steel	1
8	171941	SPRING, compression; stainless steel	1
9	171942	HOUSING, filter; carbon steel	1
10	100509	PLUG, pipe; 1/4 npt	1
12	238635	VALVE, ball; 1/4 npt (mbe); carbon steel	1
15	159841	BUSHING; 3/8 npt(m) x 1/4 npt(f)	1
16	100840	ELBOW, 90°; 1/4 npt (m x f); carbon steel	1
17	162453	NIPPLE; 1/4 npt x 1/4 npsm; carbon steel	1
18	102814	GAUGE, pressure	1
22	156849	NIPPLE; 3/8 npt; carbon steel	1

✓ Keep these spare parts on hand to reduce down time.

# Parts

## Model 239063, Series A

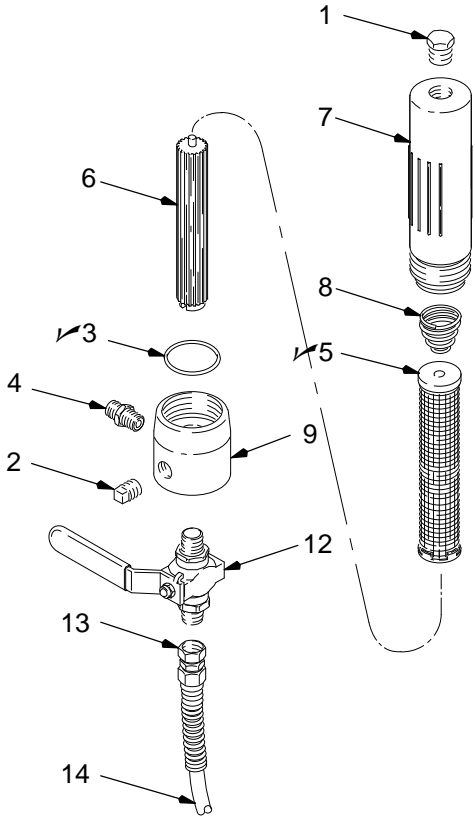

7003A

Ref No.	Part No.	Description	Qty.
1	110740	PLUG; 3/8 npt; stainless steel	1
2	111697	PLUG; 1/4 npt; stainless steel	2
3✓	104361	O-RING; PTFE	1
4	166846	NIPPLE; 1/4 npsm x 1/4 npt; stainless steel	1
5✓	167025	SCREEN, stainless steel; 60 mesh	1
6	186075	SUPPORT, filter; polyethylene	1
7	185632	BOWL, filter; stainless steel	1
8	171941	SPRING, compression; stainless steel	1
9	185631	HOUSING, filter; stainless steel	1
12	239018	VALVE, ball; 1/4 npt (mbe); stainless steel	1
13	111913	COUPLING; 1/4 npsm(f)	1
14	061132	TUBE, drain; nylon; 1/4 in. (0.6 mm) ID; 8 in. (203 mm)	1

✓ Keep these spare parts on hand to reduce down time.

## Model 24F658, Series A

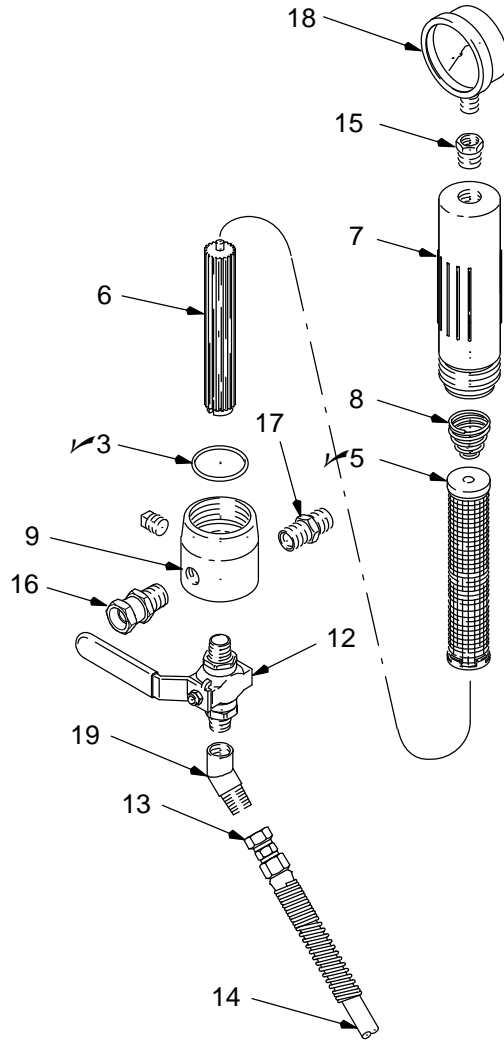

7005B

Ref No.	Part No.	Description	Qty.
3✓	104361	O-RING; PTFE	1
5✓	167025	SCREEN, stainless steel; 60 mesh	1
6	186075	SUPPORT, filter; polyethylene	1
7	185632	BOWL, filter; stainless steel	1
8	171941	SPRING, compression; stainless steel	1
9	192975	HOUSING, filter; stainless steel	1
12	239018	VALVE, ball; 1/4 npt (mbe); stainless steel	1
13	111913	COUPLING; 1/4 npsm(f)	1
14	061132	TUBE, drain; nylon; 1/4 in. (0.6 mm) ID; 8 in. (203 mm)	1
15	168160	BUSHING; 3/8 npt(m) x 1/4 npt(f)	1
16	15M859	FITTING, adapter, swivel; 1/2 npt (m) x 1/2 npsm (f); stainless steel	1
17	114572	NIPPLE; 1/2 npt x 1/2 npsm; stainless steel	1
18	112941	GAUGE, pressure	1
19	113933	ELBOW, 45°; 1/4 npt (m x f); stainless steel	1

✓ Keep these spare parts on hand to reduce down time.

# Parts

## Model 239963, Series A

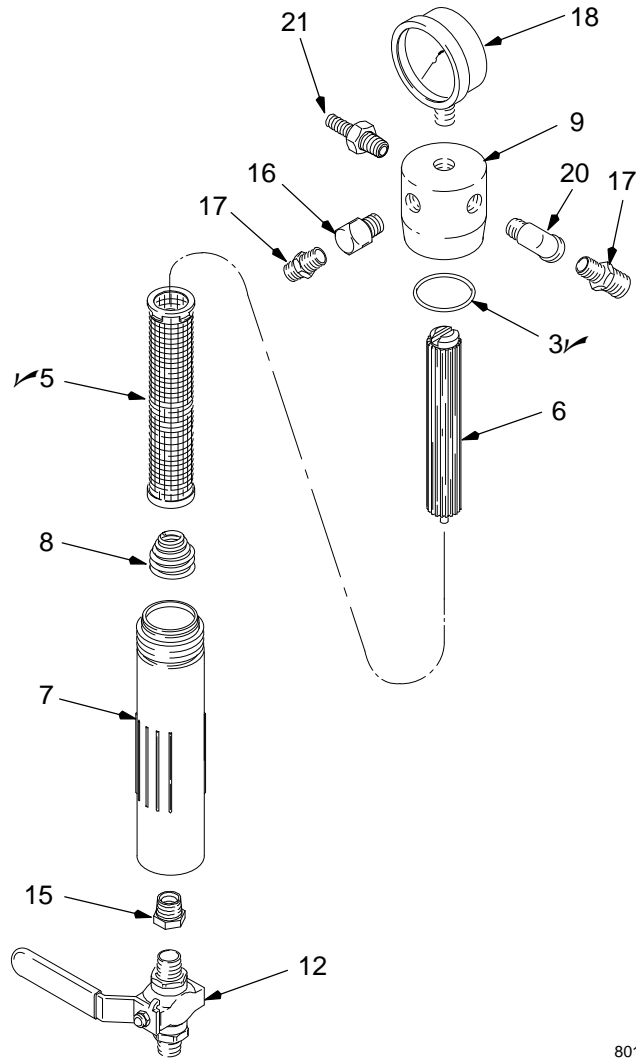

Ref. No.	Part No.	Description	Qty.
3✓	104361	O-RING; PTFE	1
5✓	167025	SCREEN, stainless steel; 60 mesh	1
6	186075	SUPPORT, filter; polyethylene	1
7	185632	BOWL, filter; stainless steel	1
8	171941	SPRING, compression; stainless steel	1
9	185631	HOUSING, filter; stainless steel	1
12	239018	VALVE, ball; 1/4 npt (mbe); stainless steel	1
15	168160	BUSHING; 3/8 npt(m) x 1/4 npt(f)	1
16	166866	ELBOW, 90°; 1/4 npt (m x f); stainless steel	1
17	166846	NIPPLE; 1/4 npt x 1/4 npsm; stainless steel	1
18	112941	GAUGE, pressure	1
20	112026	ELBOW, 90°; 3/8 npt (m x f)	1
21	192661	STUD, mounting	1
22	113070	NIPPLE; 3/8 x 1/4 npt; stainless steel	1

✓ Keep these spare parts on hand to reduce down time.

## Model 239961, Series A

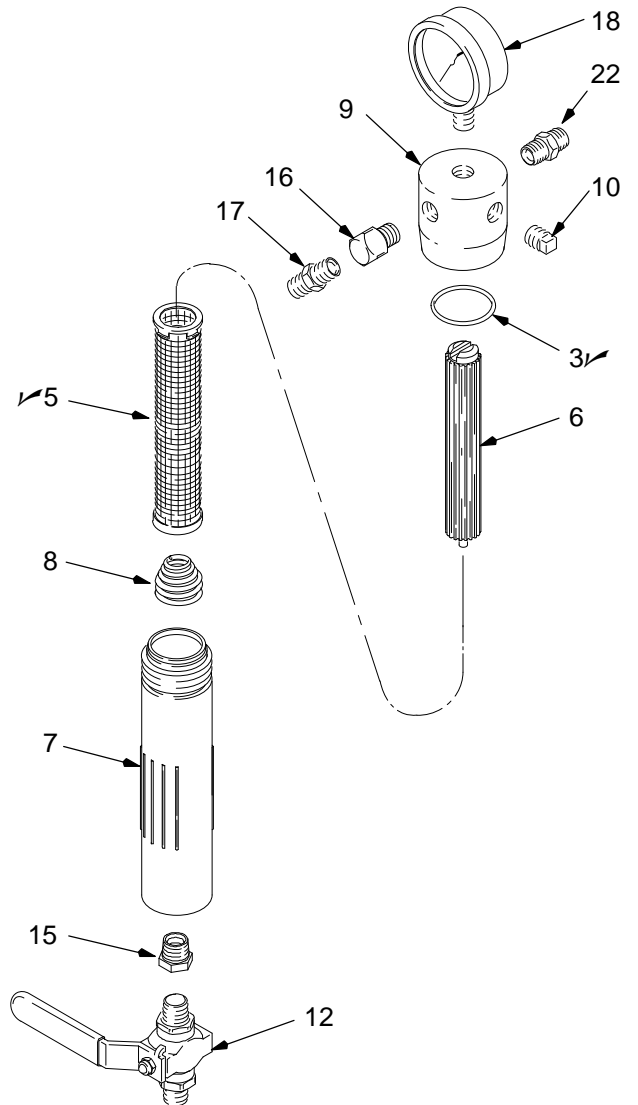

Ref. No.	Part No.	Description	Qty.
3✓	104361	O-RING; PTFE	1
5✓	167025	SCREEN, stainless steel; 60 mesh	1
6	186075	SUPPORT, filter; polyethylene	1
7	185632	BOWL, filter; stainless steel	1
8	171941	SPRING, compression; stainless steel	1
9	185631	HOUSING, filter; stainless steel	1
10	111697	PLUG; 1/4 npt; stainless steel	1
12	239018	VALVE, ball; 1/4 npt (mbe); stainless steel	1
15	168160	BUSHING; 3/8 npt(m) x 1/4 npt(f)	1
16	166866	ELBOW, 90°; 1/4 npt (m x f); stainless steel	1
17	166846	NIPPLE; 1/4 npt x 1/4 npsm; stainless steel	1
18	112941	GAUGE, pressure	1
22	111873	NIPPLE; 3/8 npt; stainless steel	1

✓ Keep these spare parts on hand to reduce down time.

# Parts

## Model 240169, Series A

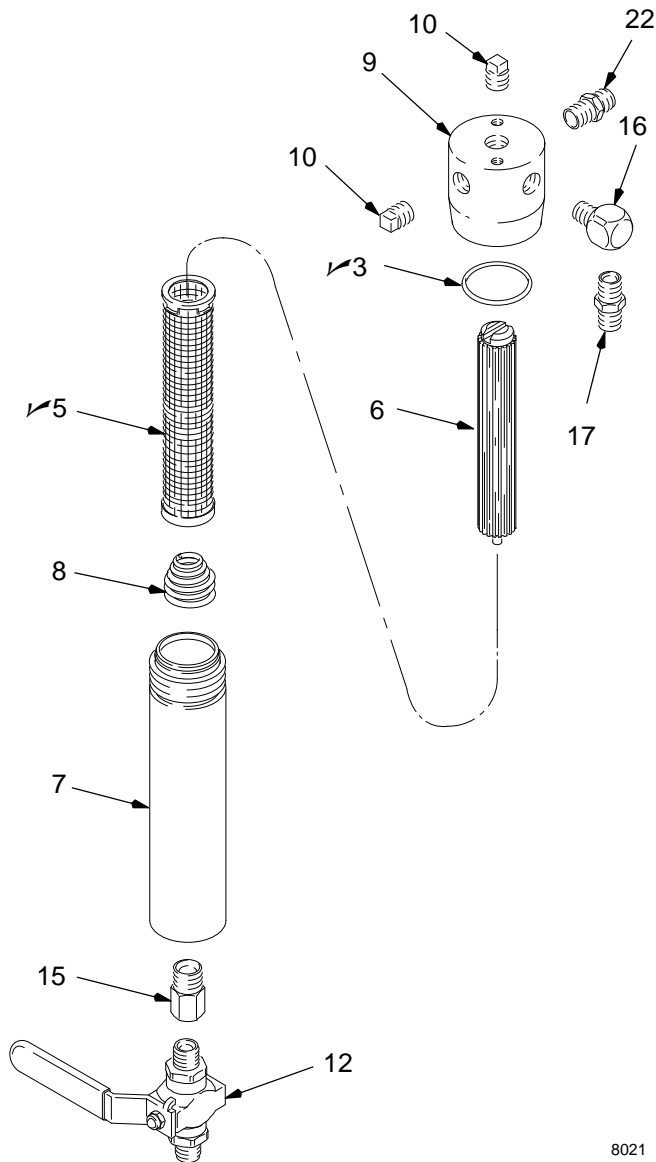

8021

## Model 240170, Series A

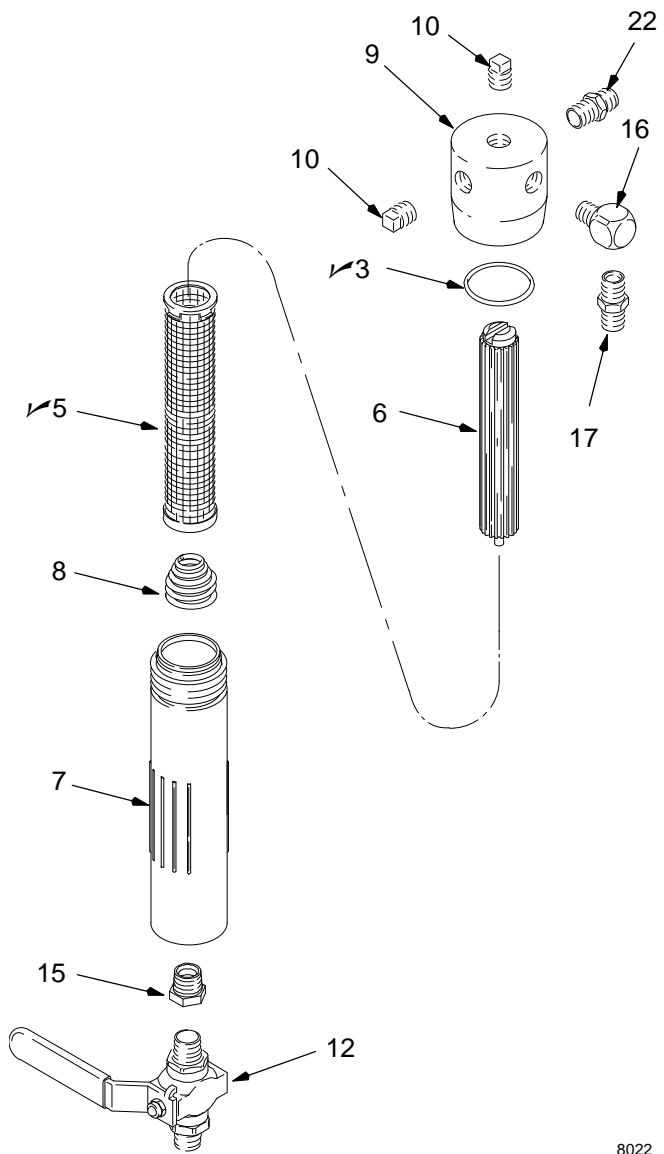

8022

Ref. No.	Part No.	Description	Qty.
3✓	104361	O-RING; PTFE	1
5✓	167025	SCREEN, stainless steel; 60 mesh	1
6	186075	SUPPORT, filter; polyethylene	1
7	24C501	BOWL, filter; carbon steel	1
8	171941	SPRING, compression; stainless steel	1
9	171942	HOUSING, filter; carbon steel	1
10	100509	PLUG, pipe; 1/4 npt	2
12	238635	VALVE, ball; 1/4 npt (mbe); carbon steel	1
15	159841	BUSHING; 3/8 npt(m) x 1/4 npt(f)	1
16	100840	ELBOW, 90°; 1/4 npt (m x f); carbon steel	1
17	162453	NIPPLE; 1/4 npt x 1/4 npsm; carbon steel	1
22	156849	NIPPLE; 3/8 npt; carbon steel	1

Ref. No.	Part No.	Description	Qty.
3✓	104361	O-RING; PTFE	1
5✓	167025	SCREEN, stainless steel; 60 mesh	1
6	186075	SUPPORT, filter; polyethylene	1
7	185632	BOWL, filter; stainless steel	1
8	171941	SPRING, compression; stainless steel	1
9	185631	HOUSING, filter; stainless steel	1
10	111697	PLUG; 1/4 npt; stainless steel	2
12	239018	VALVE, ball; 1/4 npt (mbe); stainless steel	1
15	168160	BUSHING; 3/8 npt(m) x 1/4 npt(f)	1
16	166866	ELBOW, 90°; 1/4 npt (m x f); stainless steel	1
17	166846	NIPPLE; 1/4 npt x 1/4 npsm; stainless steel	1
22	111873	NIPPLE; 3/8 npt; stainless steel	1

✓ Keep these spare parts on hand to reduce down time.

✓ Keep these spare parts on hand to reduce down time.



# Parts

## Model 239286, Series A

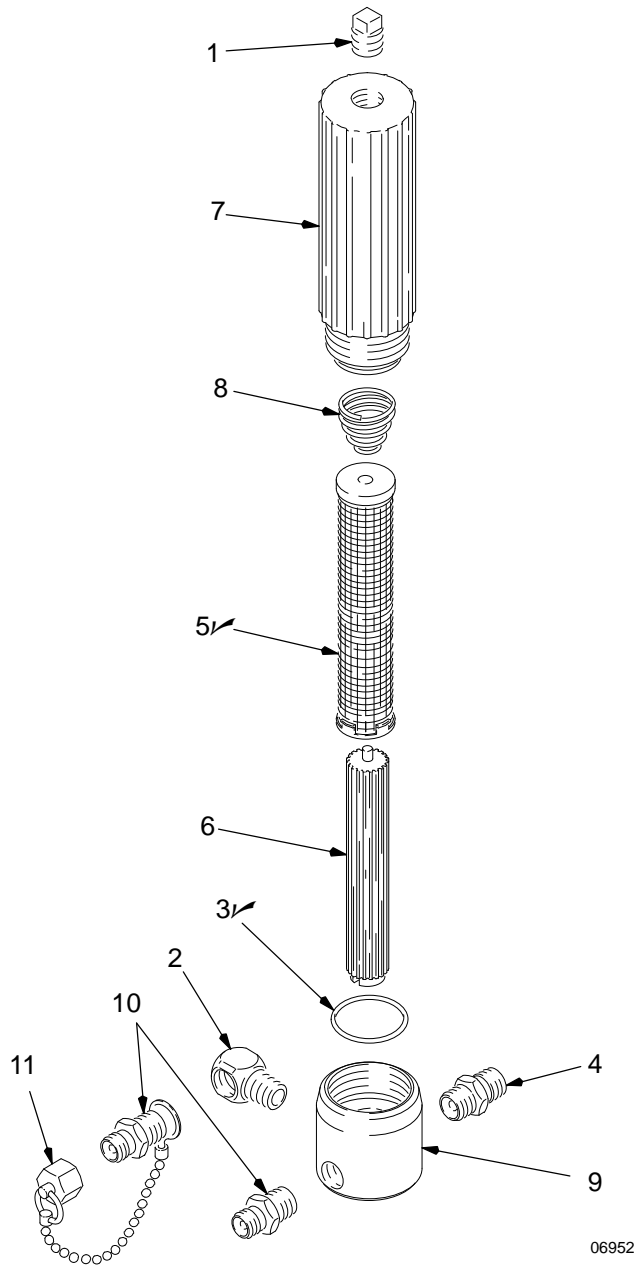

06952

Ref No.	Part No.	Description	Qty.
1	100040	PLUG; 3/8 npt; steel or iron	1
2	155699	ELBOW, street, 3/8-18 (m x f)	1
3✓	104361	O-RING; PTFE	1
4	162485	NIPPLE; 3/8 npt(m) x 3/8 npsm(m)	1
5✓	167025	SCREEN, stainless steel; 60 mesh	1
6	186075	SUPPORT, filter; polyethylene	1
7	172831	BOWL, filter; aluminum	1
8	171941	SPRING, compression; stainless steel	1
9	190097	HOUSING, filter; carbon steel	1
10	164672	NIPPLE, hex, 3/8 npt x 1/4 npsm; 1-15/16 in. long	2
11	239285	CAP, filter	1

✓ Keep these parts on hand to reduce down time.

## Model 237481, Series A Model 241107, Series A

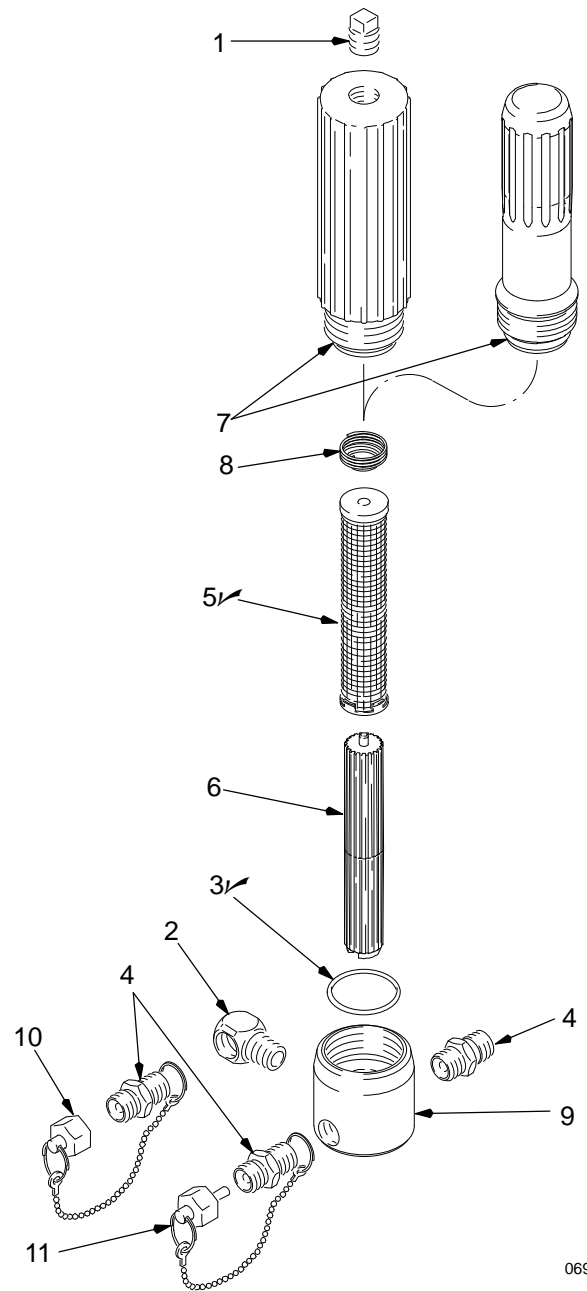

06953A

Ref No.	Part No.	Description	Qty.
1	100040	PLUG; 3/8 npt; steel or iron; (231481)	1
2	155699	ELBOW, street, 3/8-18 (m x f)	1
3✓	104361	O-RING; PTFE	1
4	162485	NIPPLE; 3/8 npt(m) x 3/8 npsm(m)	3
5✓	167025	SCREEN, stainless steel; 60 mesh	1
6	186075	SUPPORT, filter; polyethylene	1
7	172831	BOWL, filter; aluminum; Model 237481	1
	246582	BOWL, filter; zinc-plated steel; Model 241107	1
8	171941	SPRING, compression; stainless steel	1
9	190097	HOUSING, filter; carbon steel	1
10	237479	CAP, filter; Model 237481	1
11	240987	PLUG, packless; Model 241107	1

✓ Keep these parts on hand to reduce down time. 10Parts

# Parts

## Model 24F620, Series A

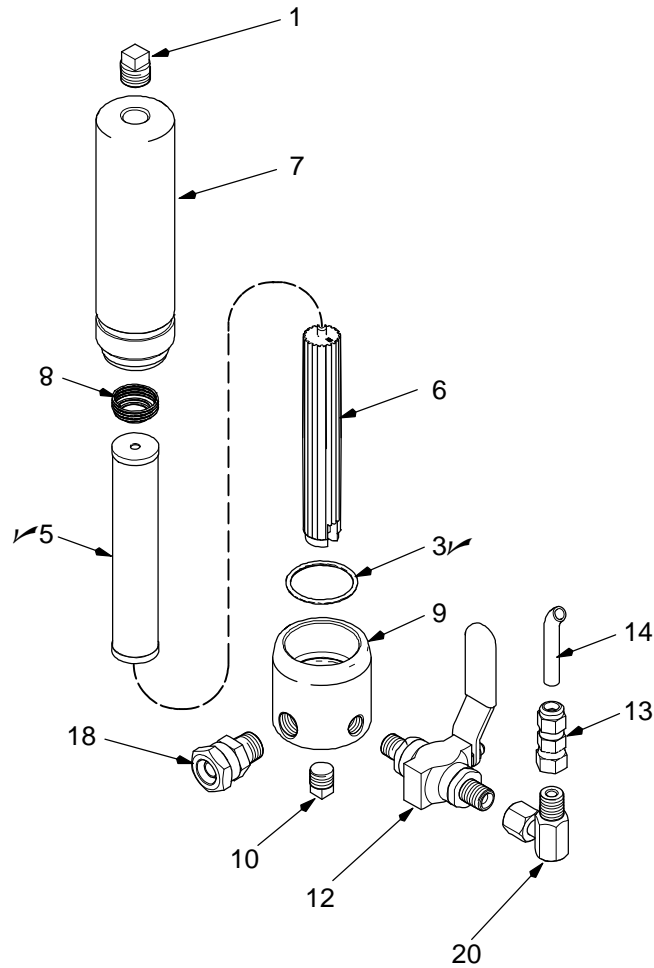

T119255a

## Model 24U609, Series A

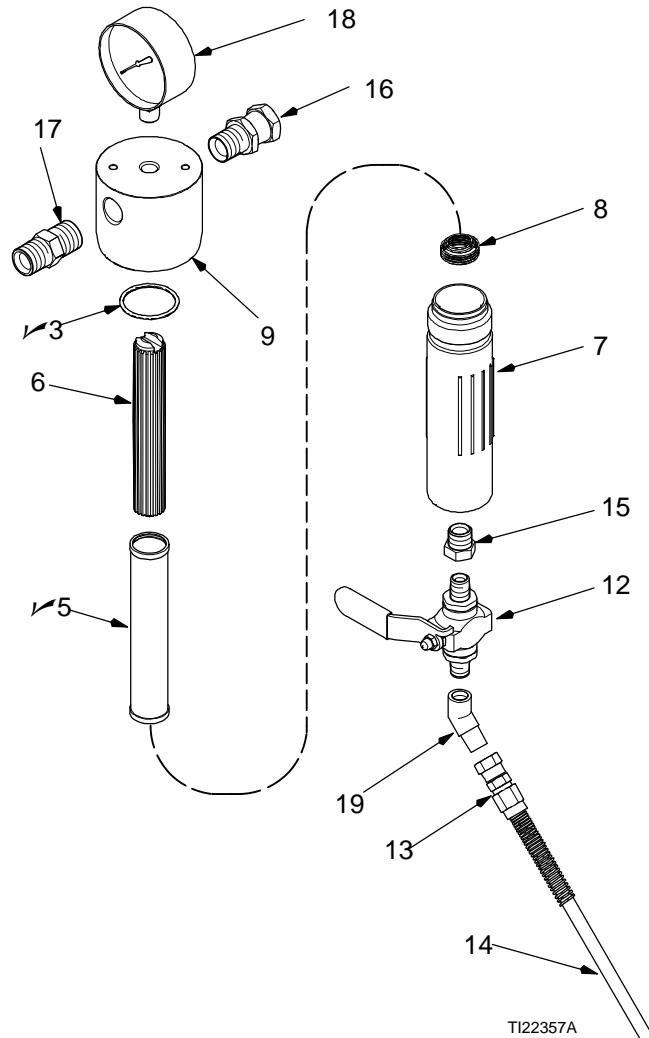

TI22357A

Ref. No.	Part No.	Description	Qty.
1	100040	PLUG; 3/8 npt; steel or iron	1
3✓	104361	O-RING; PTFE	1
5✓	167026	SCREEN, stainless steel; 100 mesh	1
6	186075	SUPPORT, filter; polyethylene	1
7	24C501	BOWL, filter; carbon steel	1
8	171941	SPRING, compression; stainless steel	1
9	171942	HOUSING, filter; carbon steel	1
10	100509	PLUG, pipe; 1/4 npt	1
12	238635	VALVE, ball; 1/4 npt (mbe); carbon steel	1
13	205447	COUPLING; 1/4 npsm(f)	1
14	061132	TUBE, drain; nylon; 1/4 in. (0.6 mm) ID; 7 ft (2.1 m)	1
18	GC2069	FITTING, swivel; 3/8 npt(m) x 3/8 npsm(f)	1
20	155541	FITTING, elbow, swivel; 1/4 npt(m) x 1/4 npsm(f)	1

Ref No.	Part No.	Description	Qty.
3✓	104361	O-RING; PTFE	1
5✓	167025	SCREEN, stainless steel; 60 mesh	1
6	186075	SUPPORT, filter; polyethylene	1
7	185632	BOWL, filter; stainless steel	1
8	171941	SPRING, compression; stainless steel	1
9	192975	HOUSING, filter; stainless steel	1
12	239018	VALVE, ball; 1/4 npt (mbe); stainless steel	1
13	111913	COUPLING; 1/4 npsm(f)	1
14	061132	TUBE, drain; nylon; 1/4 in. (0.6 mm) ID; 8 in. (203 mm)	1
15	168160	BUSHING; 3/8 npt(m) x 1/4 npt(f)	1
16	15M859	FITTING, adapter, swivel; 1/2 npt (m) x 1/2 npsm (f); stainless steel	1
17	114572	NIPPLE; 1/2 npt x 1/2 npsm; stainless steel	1
18	112941	GAUGE, pressure	1
19	113933	ELBOW, 45°; 1/4 npt (m x f); stainless steel	1

✓ Keep these spare parts on hand to reduce down time.

✓ Keep these spare parts on hand to reduce down time.

# Accessories

*Use Only Genuine Graco Parts and Accessories*

## High Pressure Ball Valves

*5000 psi (350 bar) Maximum Working Pressure*

Install in outlets for individual line control or install in bottom of filter bowl for draining fluid.

<b>210657</b>	1/4 npt(mbe), fluoroelastomer seals
<b>210659</b>	3/8 x 1/4 npt(mbe), fluoroelastomer seals
<b>210658</b>	3/8 npt(mbe), fluoroelastomer seals
<b>214037</b>	1/4 npt(mbe), PTFE seals
<b>240410</b>	3/8 npt(mbe), PTFE seals
<b>26A068</b>	3/8x1/4 npt, PTFE seals
<b>26A078</b>	1/4 npt, PTFE seals

## Stainless Steel Screens

<b>167024</b>	595 micron (30 mesh)
<b>167025</b>	250 micron (60 mesh)
<b>167026</b>	149 micron (100 mesh)
<b>167027</b>	74 micron (200 mesh)
<b>17K787</b>	149 micron (100 mesh) 316 sst

## Optional Filter Support

<b>179801</b>	Zinc-plated steel
---------------	-------------------

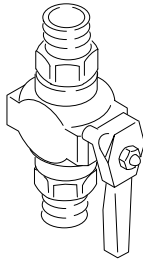

# Notes

# Technical Data

Category	Data
Maximum Working Pressure	<i>Model 214570, 236789, 237481, 239286:</i> 3000 psi (21 MPa, 210 bar) <i>Model 239963:</i> 4000 psi (28 MPa, 280 bar) <i>All other models:</i> 5000 psi (35 MPa, 350 bar)
Fluid Inlet	<i>Models 240183, 24U609, and 24F658:</i> 1/2 npt <i>All other models:</i> 3/8 npt
Fluid Outlets	<i>Models 240183, 24U609, and 24F658:</i> 1/2 npt <i>Model 236789, 237481, 238782, 241107, 248851:</i> 3/8 npt <i>All other models:</i> 1/4 npt
Diameter	<i>All models:</i> 2.25 in. (60 mm)
Height	<i>All models:</i> 8.5 in. (220 mm)
Weight	<i>Model 214570, 236789:</i> 3.2 lb (1.45 kg) <i>Model 237481, 239286 :</i> 3.53 lb (1.60 kg) <i>All other models:</i> 4.63 lb (2.10 kg)
Wetted Parts	<i>Models 214570, 236789, 237481, 239286:</i> Aluminum, carbon steel, passivated 304 & 313 stainless steel, PTFE, polyethylene  <i>Models 218029, 239060, 24F620, 239244, 239962, 239964, 240169, 241107, 24V925:</i> Carbon steel, PTFE, polyethylene, passivated 304 & 313 stainless steel  <i>Model 241317:</i> Carbon steel, zinc, PTFE, polyethylene, passivated 304 & 313 stainless steel  <i>Models 223160, 238782, 239063, 239300, 239800, 239961, 239963, 24A587, 240170, 240183, 248851, 24U609, and 24F658:</i> PTFE, polyethylene, passivated 303, 304, 313 & 316 stainless steel  <i>Model 26A069:</i> PTFE, 316 sst passivated, polyethylene

# Graco Standard Warranty

Graco warrants all equipment manufactured by Graco and bearing its name to be free from defects in material and workmanship on the date of sale to the original purchaser for use. With the exception of any special, extended, or limited warranty published by Graco, Graco will, for a period of twelve months from the date of sale, repair or replace any part of the equipment determined by Graco to be defective. This warranty applies only when the equipment is installed, operated and maintained in accordance with Graco's written recommendations.

This warranty does not cover, and Graco shall not be liable for general wear and tear, or any malfunction, damage or wear caused by faulty installation, misapplication, abrasion, corrosion, inadequate or improper maintenance, negligence, accident, tampering, or substitution of non-Graco component parts. Nor shall Graco be liable for malfunction, damage or wear caused by the incompatibility of Graco equipment with structures, accessories, equipment or materials not supplied by Graco, or the improper design, manufacture, installation, operation or maintenance of structures, accessories, equipment or materials not supplied by Graco.

This warranty is conditioned upon the prepaid return of the equipment claimed to be defective to an authorized Graco distributor for verification of the claimed defect. If the claimed defect is verified, Graco will repair or replace free of charge any defective parts. The equipment will be returned to the original purchaser transportation prepaid. If inspection of the equipment does not disclose any defect in material or workmanship, repairs will be made at a reasonable charge, which charges may include the costs of parts, labor, and transportation.

**THIS WARRANTY IS EXCLUSIVE, AND IS IN LIEU OF ANY OTHER WARRANTIES, EXPRESS OR IMPLIED, INCLUDING BUT NOT LIMITED TO WARRANTY OF MERCHANTABILITY OR WARRANTY OF FITNESS FOR A PARTICULAR PURPOSE.**

Graco's sole obligation and buyer's sole remedy for any breach of warranty shall be as set forth above. The buyer agrees that no other remedy (including, but not limited to, incidental or consequential damages for lost profits, lost sales, injury to person or property, or any other incidental or consequential loss) shall be available. Any action for breach of warranty must be brought within two (2) years of the date of sale.

Graco makes no warranty, and disclaims all implied warranties of merchantability and fitness for a particular purpose in connection with accessories, equipment, materials or components sold but not manufactured by Graco. These items sold, but not manufactured by Graco (such as electric motors, switches, hose, etc.), are subject to the warranty, if any, of their manufacturer. Graco will provide purchaser with reasonable assistance in making any claim for breach of these warranties.

In no event will Graco be liable for indirect, incidental, special or consequential damages resulting from Graco supplying equipment hereunder, or the furnishing, performance, or use of any products or other goods sold hereto, whether due to a breach of contract, breach of warranty, the negligence of Graco, or otherwise.

## **FOR GRACO CANADA CUSTOMERS**

The parties acknowledge that they have required that the present document, as well as all documents, notices and legal proceedings entered into, given or instituted pursuant hereto or relating directly or indirectly hereto, be drawn up in English. Les parties reconnaissent avoir convenu que la rédaction du présente document sera en Anglais, ainsi que tous documents, avis et procédures judiciaires exécutés, donnés ou intentés à la suite de ou en rapport, directement ou indirectement, avec les procédures concernées.

## Graco Information

For the latest information about Graco products, visit [www.graco.com](http://www.graco.com). For patent information, see [www.graco.com/patents](http://www.graco.com/patents).

**TO PLACE AN ORDER**, contact your Graco distributor, or call to identify the distributor closest to you:

**Phone:** 612-623-6921 **or Toll Free:** 1-800-328-0211 **Fax:** 612-378-3505

*All written and visual data contained in this document reflects the latest product information available at the time of publication.*

*Graco reserves the right to make changes at any time without notice.*

Original Instructions. This manual contains English. MM 307273

For patents go to [www.graco.com/patents](http://www.graco.com/patents).

**Graco Headquarters:** Minneapolis

**International Offices:** Belgium, China, Japan, Korea

**GRACO INC. AND SUBSIDIARIES • P.O. BOX 1441 • MINNEAPOLIS, MN 55440-1441 • USA**

Copyright 1977, Graco Inc. All Graco manufacturing locations are registered to ISO 9001.

[www.graco.com](http://www.graco.com)

Revision E, October 2016