

# HTX 2030

313890H  
EN

- For Portable Airless and Air-Assisted Spraying of Water-Based Architectural Coatings with Base Coat Pump -  
- For Airless Spraying Architectural Coatings and Paints with Top Coat Pump -



## IMPORTANT SAFETY INSTRUCTIONS

Read all warnings and instructions in this manual. Save these instructions.

**Model 257369:** HTX2030 FreeFlow Inline Gun

**Model 278675:** HTX2030 AirSpray Trigger Gun

### Maximum Working Pressure:

**Base Coat Pump:** 1000 psi (69 bar, 6.9 MPa)

**Top Coat Pump:** 3300 psi (228 bar, 22.8 MPa)

### Related Manuals:

- 313888 - Operation (English)
- 313891 - Operation (French)
- 313893 - Operation (Spanish)
- 313889 - Repair (English)
- 313892 - Repair (French)
- 313894 - Repair (Spanish)
- 313895 - HTX 2030 Flex Head and Pole Spray Applicator (English)
- 313896 - HTX 2030 Flex Head and Pole Spray Applicator (French)
- 313897 - HTX 2030 Flex Head and Pole Spray Applicator (Spanish)
- 310894 - Displacement Pump (Top Coat)
- 308491 - Texture Airless Spray Gun
- 313537 - HTX 2030 Applicator (English)
- 313603 - HTX 2030 Applicator (Chinese)
- 313908 - HTX 2030 Applicator (French)
- 313911 - HTX 2030 Applicator (Spanish)
- 332160 - HTX2030 AirSpray Trigger Gun (English)
- 332227 - HTX2030 AirSpray Trigger Gun (French)
- 332228 - HTX2030 AirSpray Trigger Gun (Spanish)
- 332229 - HTX2030 AirSpray Trigger Gun (Chinese)

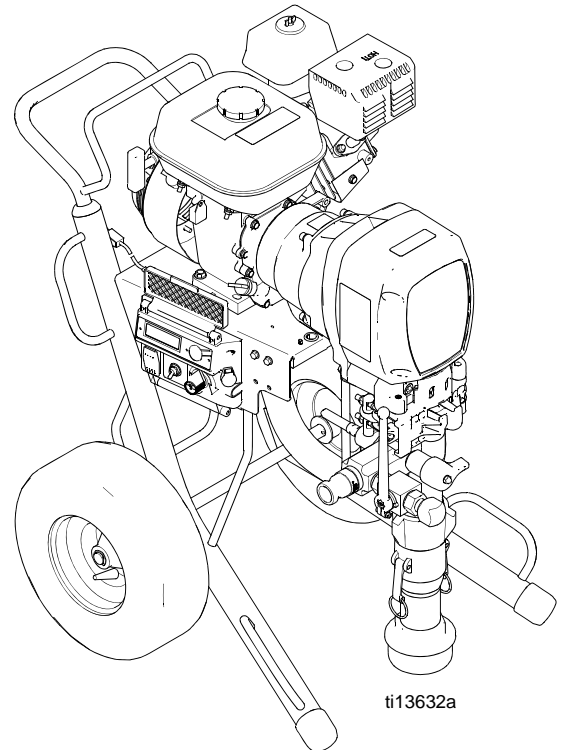

# Parts

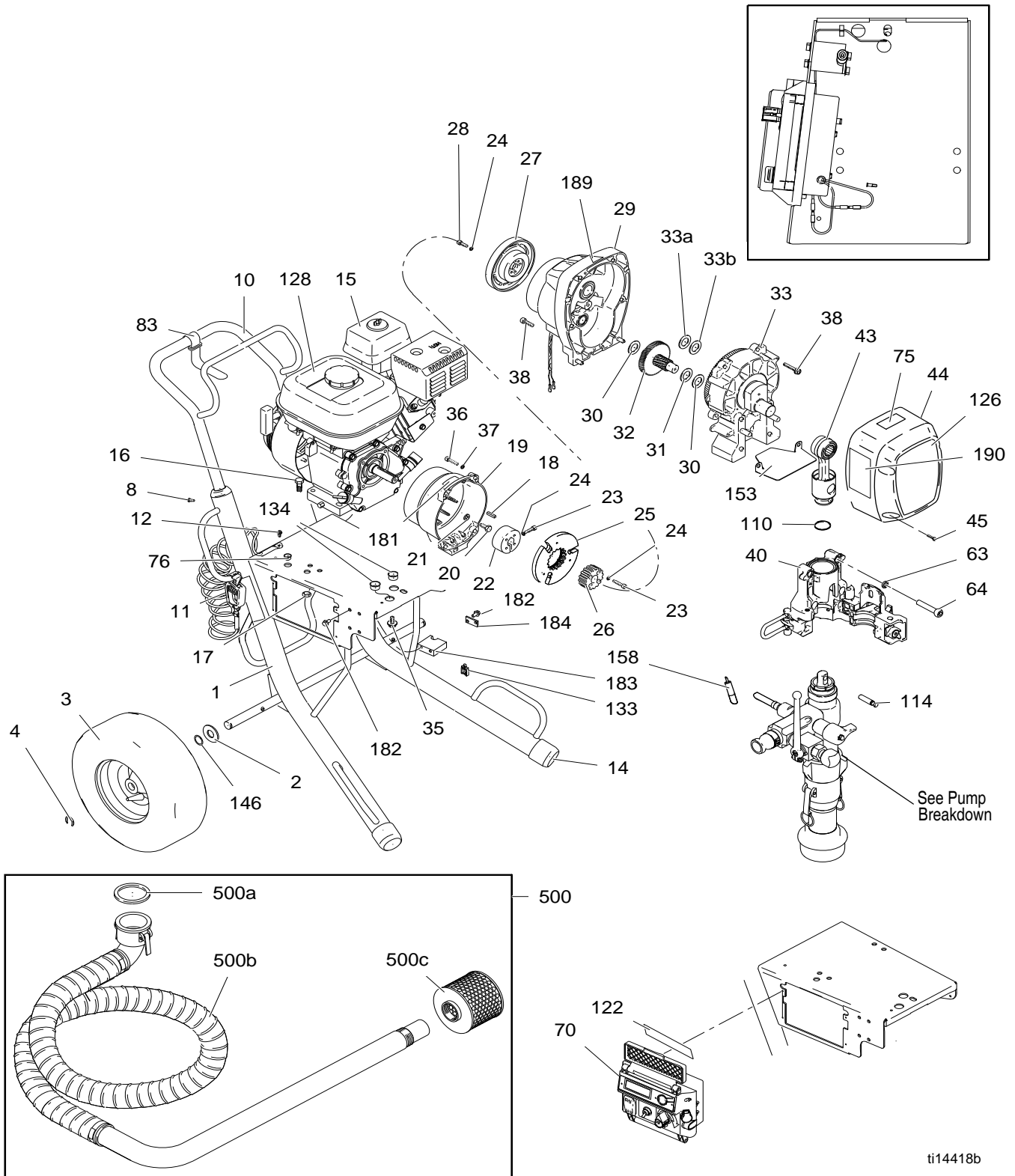

## Parts List

Ref.	Part	Description	Qty	Ref.	Part	Description	Qty
1	24A852	FRAME, cart, HTX 2030	1	63	112600	WASHER, lock	4
2	156306	WASHER, flat	2	64	112599	SCREW, cap, socket head	4
3	119509	WHEEL, pneumatic	2	70	24B324	PRESSURE CONTROL BOX	1
4	15E891	CLIP, retaining	2	75	15F584	LABEL, proconnect	1
8	108795	SCREW, mach, pnh	4	76	114678	BUSHING, strain relief	1
10	24A250	HANDLE, assy	1	83	114271	STRAP, retaining	1
11	237686	WIRE, ground assembly w/ clamp	1	110	119677	SPRING, retaining	1
12	112798	SCREW, thread forming, hex hd	1	114	15F097	PIN, pump	1
14	276974	CAP, leg	2	122	15F755	LABEL, identification	1
15	116080	ENGINE, GAS, 6.5 hp, Honda	1	126	15X908	LABEL, identification	1
16	110837	SCREW, flange, hex	2	128▲	194126	LABEL, warning	1
17	110838	NUT, lock	2	133	114687	CLIP, retainer	1
18	183401	KEY, parallel	1	134	119569	BUSHING, strain relief	2
19	15E277	HOUSING, clutch, mach	1	146	116038	WASHER, wave spring	2
20	108842	SCREW, cap, hex hd	4	153	15X174	SHIELD, cable	1
21	100214	WASHER, lock	4	158	24B560	TRANSDUCER, handtight, 5000 psi	1
22	193680	COLLAR, shaft	1	180	206994	FLUID, TSL, 8 OZ (not shown)	1
23†	108803	SCREW, hex, socket head	6	181	15Y118	LABEL, Made in the USA	1
24†	105510	WASHER, lock, spring (hi-collar)	10	182	113161	SCREW, flange, hex hd	4
25†		ARMATURE, clutch, 5 in.	1	183	15Y139	BLOCK, mounting, transducer	1
26†		HUB, armature	1	184	15Y140	COVER, block, mounting	1
27†		ROTOR, clutch, 5 in.	1	189▲	15K616	LABEL, caution	1
28†	101682	SCREW, cap, sch	4	190▲	16A617	LABEL, warning, English	1
29	287466	HOUSING, pinion	1	191▲	16A618	LABEL, warning, Spanish	1
30	114672	WASHER, thrust	2	192▲	16A704	LABEL, warning, French	1
31	114699	WASHER, thrust	1	193▲	16A705	LABEL, warning, Chinese	1
32	287459	GEAR, combination	1	500	224442	KIT, suction, 55 gal. (optional)	1
33	287470	HOUSING, drive	1	500a	111340	GASKET, coupler	1
33a	116192	WASHER, steel	1	500b	187123	HOSE	1
33b	194173	WASHER, bronze	1	500c	187119	STRAINER, 1/2 nps	1
35	112395	SCREW, cap, flng hd	1				
36	102962	SCREW, cap sch	4				
37	104008	WASHER, lock, spring	4				
38	15C753	SCREW, mach, hex wash hd	6				
40	24B528	HOUSING, bearing	1				
43	287473	ROD, connecting	1				
44	287520	COVER, front	1				
45	118444	SCREW, mach, slot hex wash hd	4				

▲ Replacement Danger and Warning labels, tags, and cards are available at no cost.

† Included in Clutch Replacement Kit 241113.

# Pressure Control Box 24B324

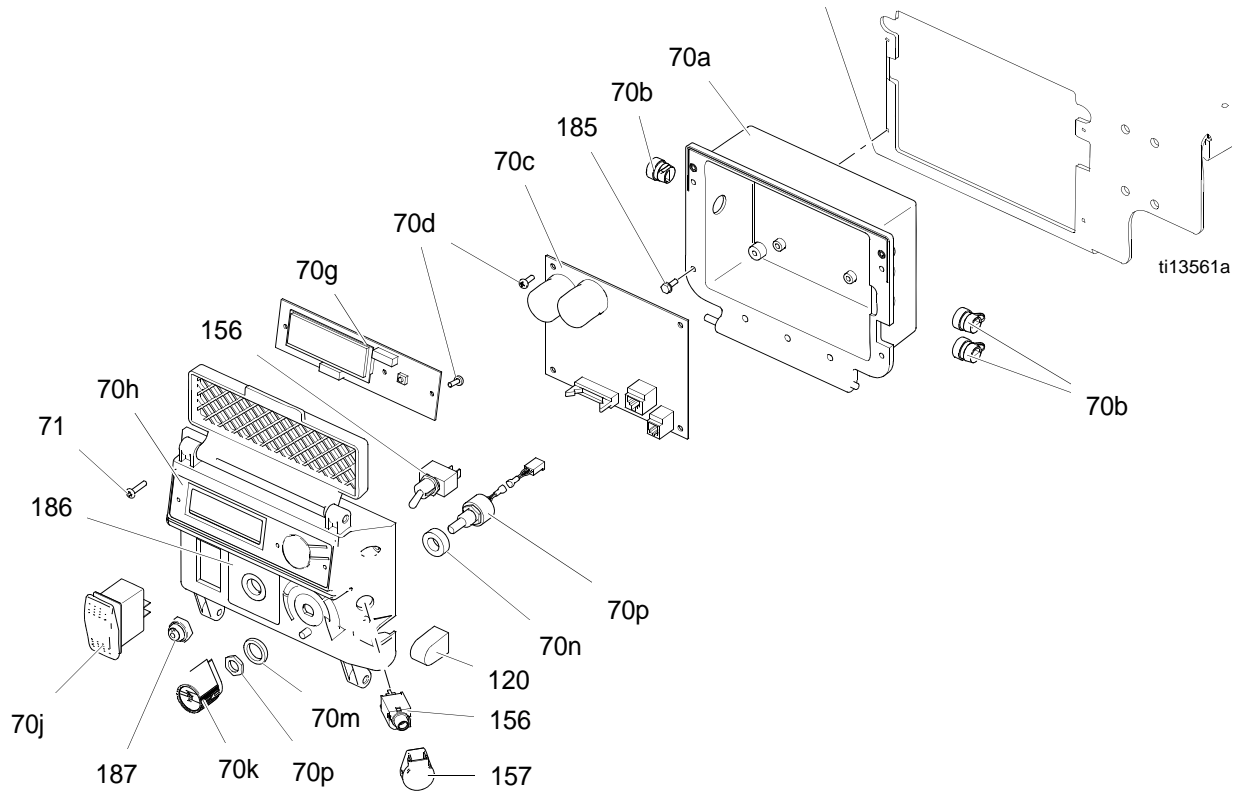

Ref.	Part	Description	Qty.
70		PRESSURE CONTROL BOX (includes all parts shown)	1
70a	24B574	BOX, control, modified	1
70b	119545	BUSHING, strain, relief	3
70c	257431	CONTROL, board	1
70d	117317	SCREW, plastite, pan head	7
70g	287515	DISPLAY, LCD	1
70h	15E855	LABEL, SmartControl	1
70j	116752	SWITCH, rocker	1
70k	116167	KNOB, pump control	1
70m	15C973	GASKET	1
70n	198650	SPACER, shaft	1
70p	256219	POTENTIOMETR, assembly	1
71	116585	SCREW, pan, cross, recess, sst	2
120	15X746	GASKET, control cover	1
156	122207	HARNESS, switch/jack	1
157	120761	COVER, jack	1
185	113160	SCREW, mach, slot, hex, wash	4
186	15Y262	LABEL, prime switch	1
187	195428	BOOT, toggle	1

# Bearing Housing 24B528

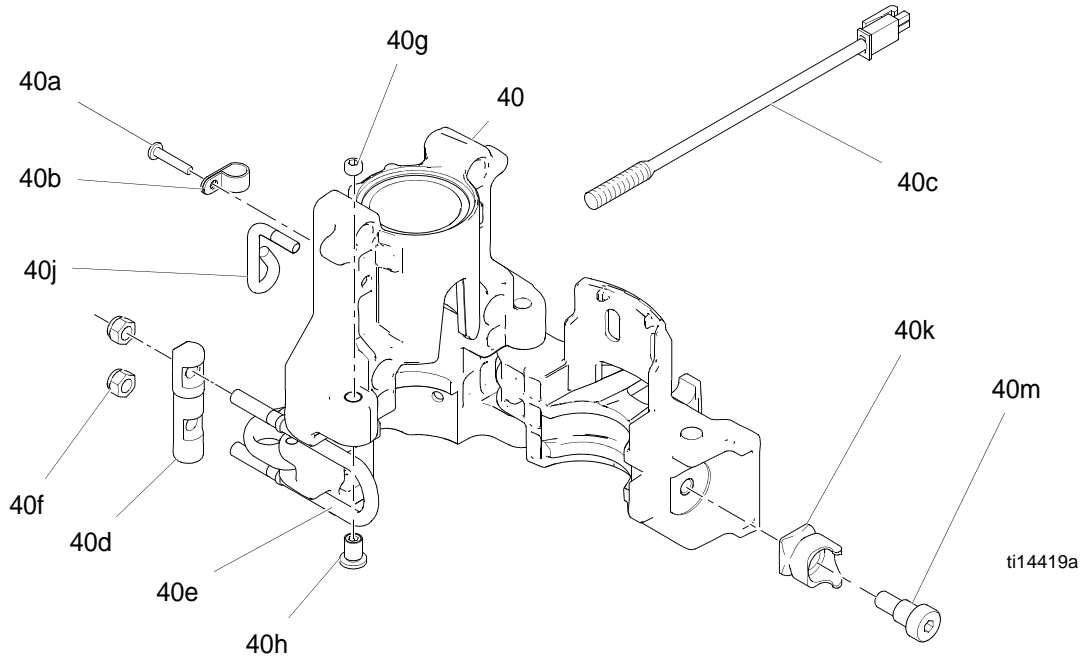

Ref.	Part	Description	Qty.
40		HOUSING, bearing	1
40a†	107251	SCREW, panhead	1
40b†	565361	CLAMP, cable	1
40c†		SENSOR, pump	1
40d†	15E625	PIN, housing, bearing	1
40e†	15G890	LATCH, housing, bearing	1
40f†	111040	NUT, lock, hex	2
40g†	15F503	SCREW, set, socket hd	1
40h†	15F498	SCREW, adjustment	1
40j†	15F116	LATCH	1
40k†	15G584	RECEIVER, latch	1
40m†	116942	SCREW, shoulder, sch	1

† Included in Bearing Housing 40.

## Base Coat Pump

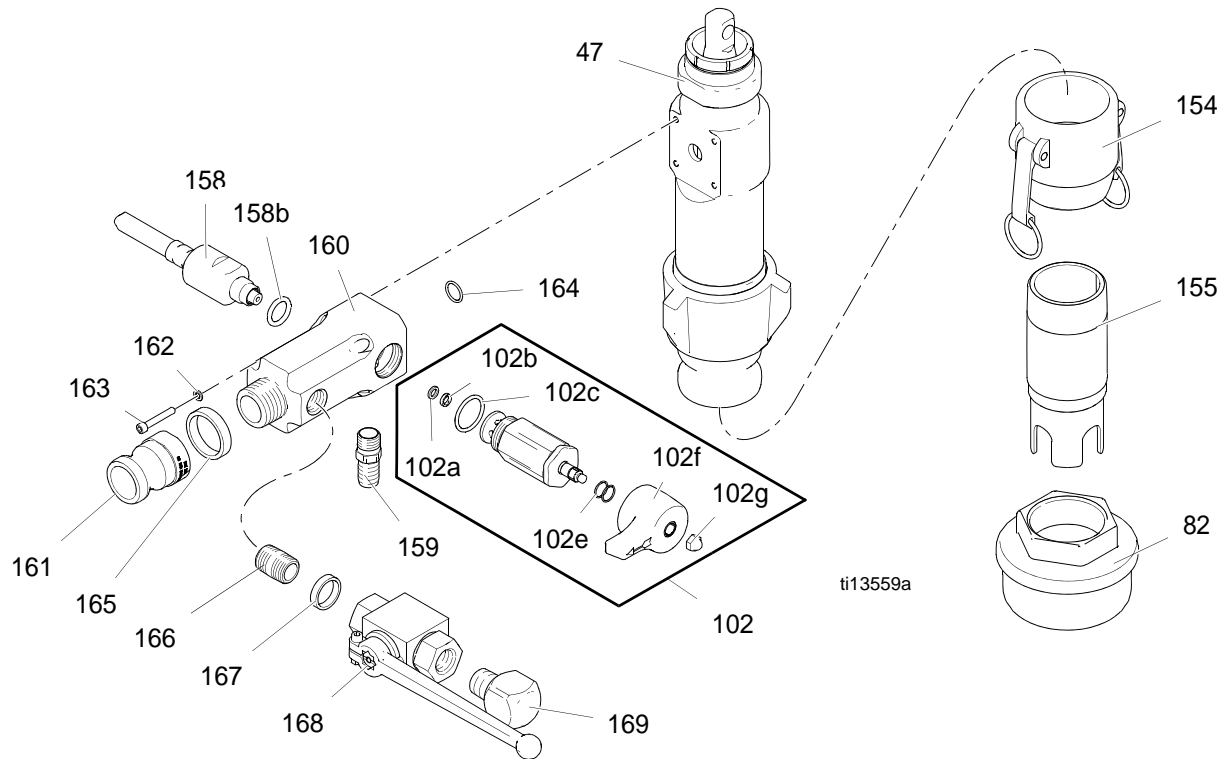

Ref.	Part	Description	Qty.
47	24B321	PUMP, displacement	1
82	15X762	STRAINER, 2 in. npt	1
102	24B572	VALVE, drain, assembly	1
102a	193710	SEAL, seat, valve	1
102b	193709	SEAT, valve	1
102c	107204	O-RING	1
102e	122287	SPRING, drain valve, knob	1
102f	15Y594	HANDLE, black, arrow, marked	1
102g	116424	NUT, cap	1
154	122602	COUPLER, cam, quick, 2 in.	1
155	15X088	EXTENSION, valve, inlet	1
158	24B560	TRANSDUCER, handtight, 5000 psi	1
158b	111710	SEAL, o-ring (included with transducer 158)	1
159	15X943	FITTING, manifold, drain tube	1
160	16C053	MANIFOLD, pump	1
161	15T116	COUPLER, male, cam and groove	1
162	100020	WASHER, lock	4
163	104705	SCREW, cap, sch	4
164	115719	PACKING, o-ring, 015, FKM	1
165	123621	RING, cover, thread 1 npt	1
166	123602	NIPPLE, close 1/2 npt sst	1
167	123622	RING, cover, thread 1/2 npt	1
168	24C750	VALVE, ball, 1/2 npt	1
169	158683	ELBOW, street, 1/2 npt	1

# Base Coat Pump 24B321

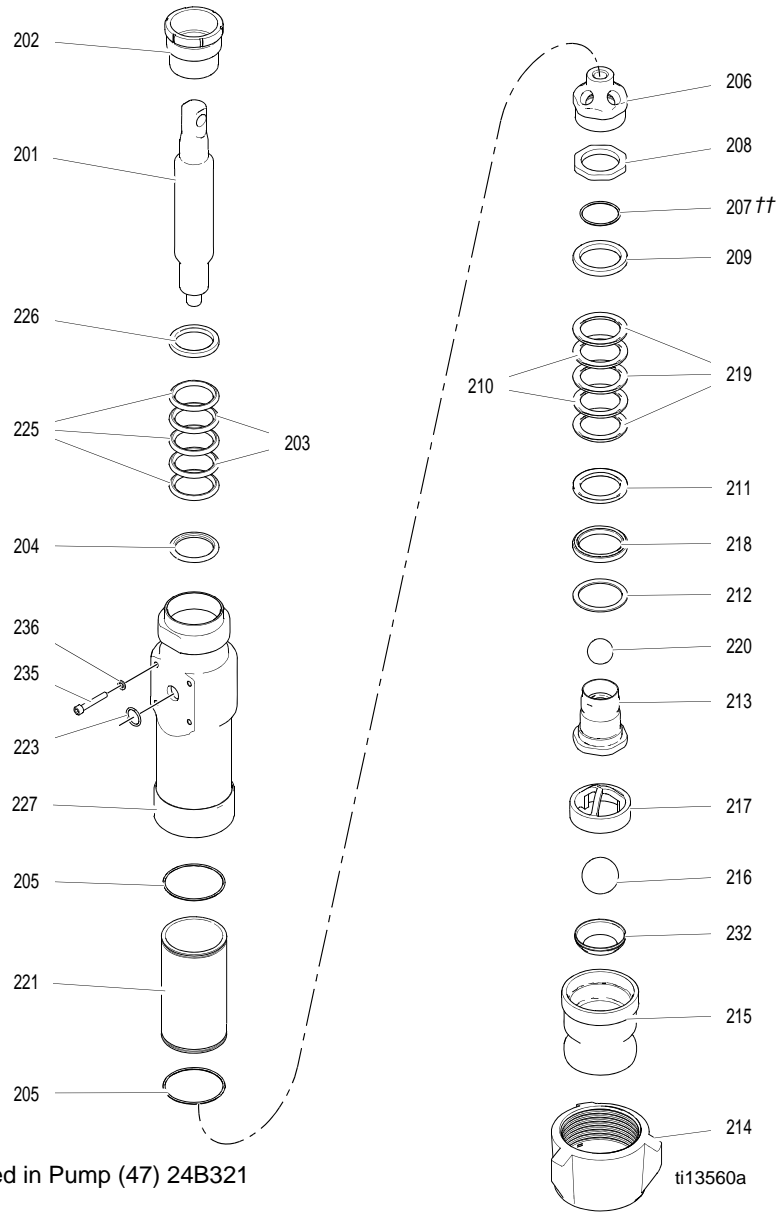

All parts shown are included in Pump (47) 24B321

Ref.	Part	Description	Qty.	Ref.	Part	Description	Qty.
201	15X090	PISTON ROD	1	217	187064	BALL GUIDE	1
202	187068	PACKING NUT	1	218	188558*	U-CUP SEAL, poly/fluoroelastomer	1
203	188560*	V-PACKING, poly	2	219	187072*	V-PACKING, polu	3
204	187939*	GLAND, male	1	220	102972*	BALL, piston, 0.875 in. ID	1
205	188557*	O-RING	2	221	187066	CYLINDER	1
206	187934	PISTON HOUSING	1	223	115719	SEAT, o-ring, manifold	1
207 ††	188559*	O-RING fluoroelastomer	1	225	187071*	V-PACKING, poly	3
208	188434*	NUT	1	226	187070*	GLAND, female	1
209	188432*	GLAND, male	1	227	15X089	HOUSING, pump	1
210	188561*	V-PACKING, poly	2	232	235962	SEAL, foot valve	1
211	188433*	GLAND, female	1	235	104705	SCREW, sockethead	4
212	188627	BACKUP WASHER, nylon	1	236	100020	WASHER, lock	4
213	235165	PISTON SEAT	1	*These parts are also included in Repair Kit 235186, which can be purchased separately.			
214	187929	LUG NUT	1	†† Not used in all revisions of pump.			
215	235963	INTAKE HOUSING	1				
216	102973*	BALL, intake, 1.25 in. ID	1				

# Texture Applicator and Hose

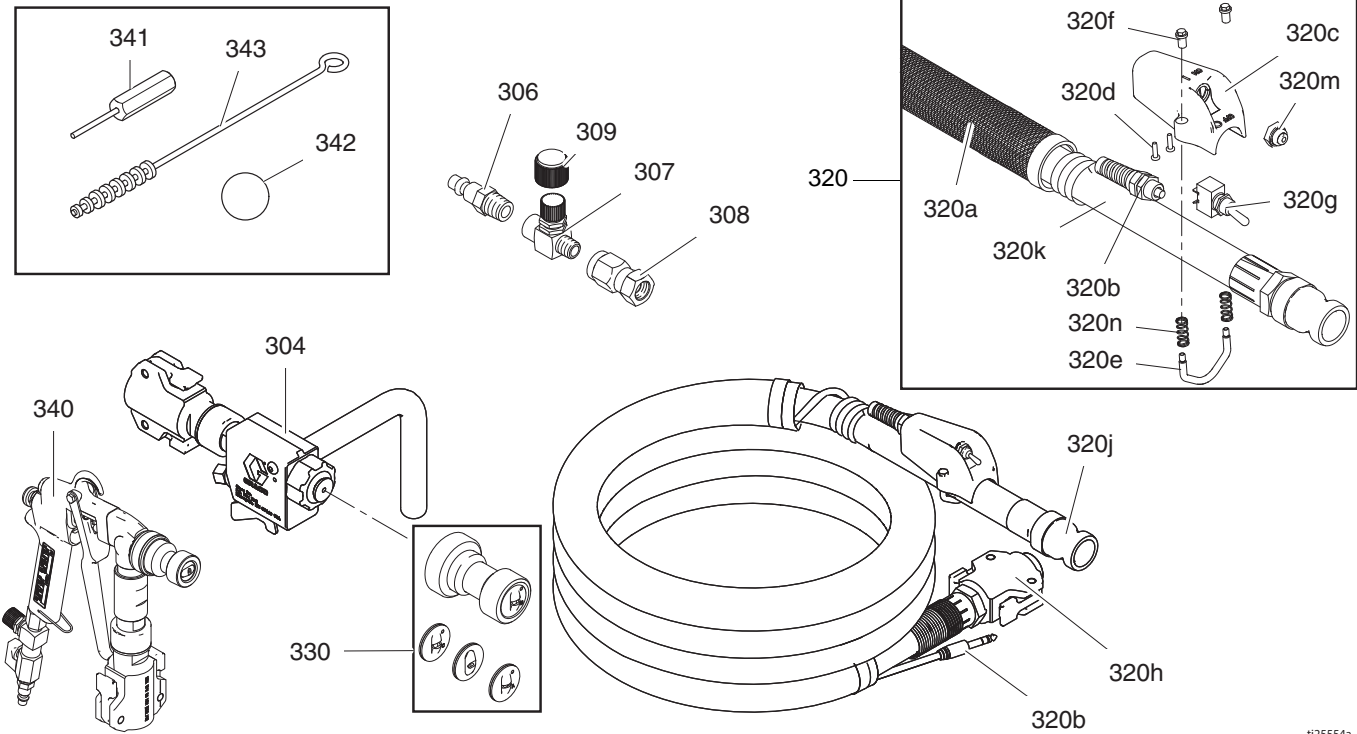

ti25554a

Ref.	Part	Description	Qty	Ref.	Part	Description	Qty
304	24B327	APPLICATOR, HTX (accessories), Model 257369, see manual 313537, 313603, 313908, 313911	1	320f†	16H087	NUT, switch	2
306	119394	FITTING, air, OD	1	320g	24B561	SWITCH, pump	1
307	112779	VALVE, air, needle	1	320h	289874	COUPLER, female	1
308	155570	UNION, swivel	1	320j	15T116	COUPLER, male	1
309	121591	KNOB, valve	1	320k	15X539	HOSE, fluid, bare	1
320		HOSE, texture (includes 320a-320k)	1		17S247	100 ft.	1
	24B300	50 ft.	1	320m†	195428	BOOT, switch	1
	17S244	100 ft. (optional)	1	320n	125058	Spring, compression	2
320a		SLEEVE, hose, shield	1	330	287227	KIT, FineFinish (see manual 310617)	1
	24X577	50 ft.	1	340	24R054	HTX2030 AirSpray Trigger Gun, Model 278675, (see manual 332160, 332227, 332228, 332229)	1
	17S245	100 ft.	1	341	248395	TOOL, cleaning, applicator	1
320b		HARNESS, switch	1	342	248515	BALL, sponge, 30 mm (5 pk)	1
	15W716	50 ft.	1	343	M70613	BRUSH, cleaning	1
	17S248	100 ft.	1				
320c†	24B559	HOUSING, switch	1				
320d†	119236	SCREWS	2				
320e†	16H086	U-BOLT	1				

† Included with switch 320g.



# Top Coat Pump Kit 24B140 (Sold Separately)

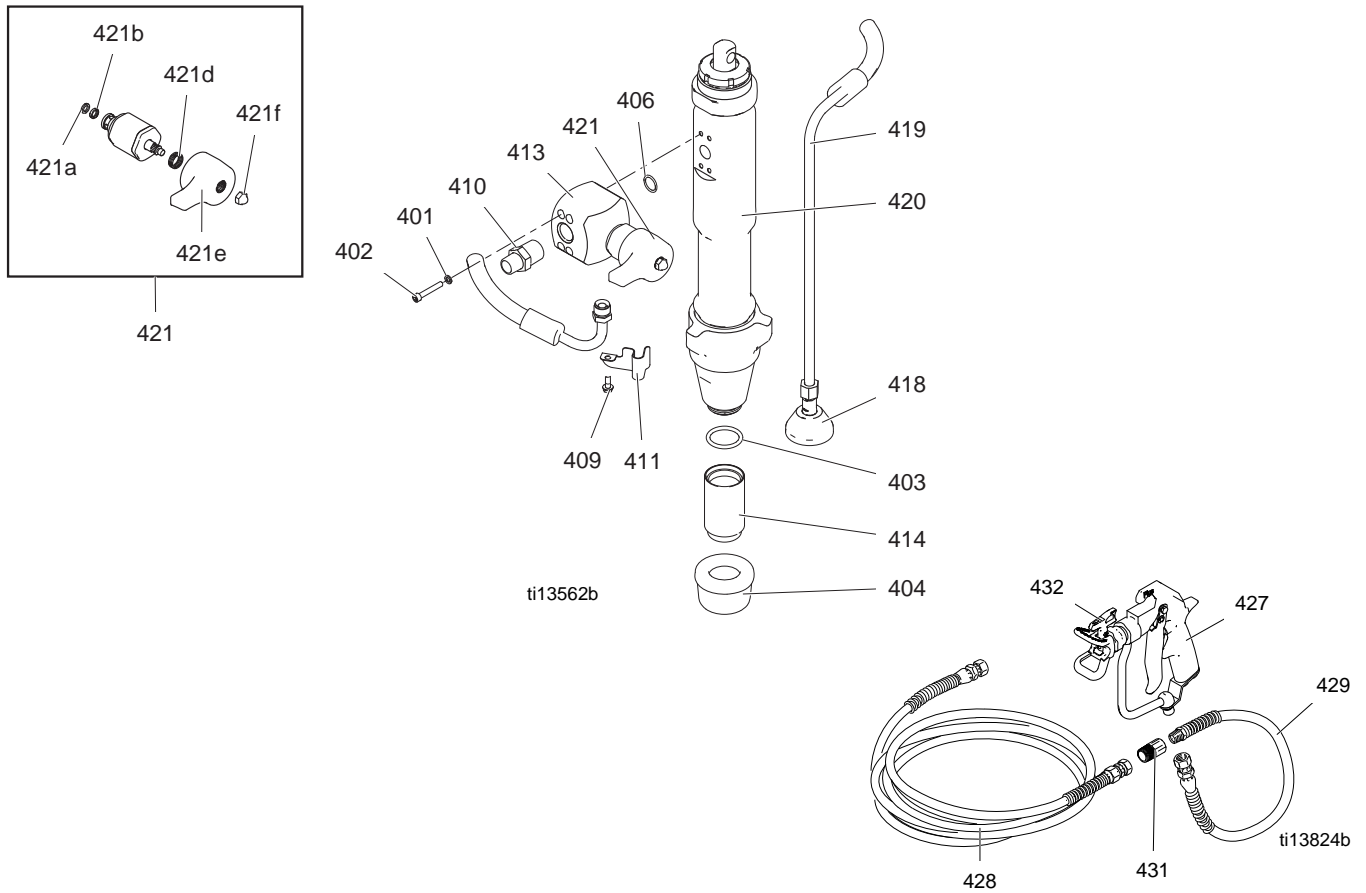

Ref.	Part	Description	Qty.	Ref.	Part	Description	Qty.
401	100020	WASHER, lock	4	421e	15Y594	HANDLE, black	1
402	104705	SCREW, cap, sch	4	421f	116424	NUT, cap	1
403	108833	PACKING, o-ring	1	427	241705	TEXTURE SPRAY GUN (includes LTX531 Switch Tip and guard; see manual 308491 for parts)	1
404	189920	STRAINER, (1-11 1/2 npsm)	1	428	240797	HOSE, grounded, nylon; 3/8 in. ID; cpld 3/8 npsm(fbe); 50 ft (15 m); spring guards both ends; 3300 psi (228 bar, 22.8 MPa)	1
406	115719	PACKING, o-ring, 015, viton	1	429	238358	HOSE, whip 1/4 in. x 3 ft	1
409	118444	SCREW, mach, slot, hex wash hd	1	431	159841	BUSHING, 3/8 x 1/4 in. x 3 ft	1
410	159239	FITTING, nipple, pip, rdcg	1	432	LTX643	SWITCH TIP 643	1
411	278204	CLIP, spring	1	433	206994	FLUID, throat seal liquid, 8 oz. (not shown)	1
413	15X083	MANIFOLD, pump	1	434	307765	MSDS, throat seal liquid (not shown)	1
414	15X085	EXTENSION, valve, inlet	1				
418	241920	DEFLECTOR, threaded	1				
419	243993	HOSE, drain	1				
420	24B322	PUMP, displacement (see manual 310894)	1				
421	24B592	VALVE, drain (includes 421a - 421f) see manual 308961	1				
421a	193709	SEAT, valve	1				
421b	193710	SEAL, seat, valve	1				
421d	114708	SPRING, compression	1				

▲ Replacement Danger and Warning labels, tags, and cards are available at no cost.





# Graco Standard Warranty

Graco warrants all equipment referenced in this document which is manufactured by Graco and bearing its name to be free from defects in material and workmanship on the date of sale to the original purchaser for use. With the exception of any special, extended, or limited warranty published by Graco, Graco will, for a period of twelve months from the date of sale, repair or replace any part of the equipment determined by Graco to be defective. This warranty applies only when the equipment is installed, operated and maintained in accordance with Graco's written recommendations.

This warranty does not cover, and Graco shall not be liable for general wear and tear, or any malfunction, damage or wear caused by faulty installation, misapplication, abrasion, corrosion, inadequate or improper maintenance, negligence, accident, tampering, or substitution of non-Graco component parts. Nor shall Graco be liable for malfunction, damage or wear caused by the incompatibility of Graco equipment with structures, accessories, equipment or materials not supplied by Graco, or the improper design, manufacture, installation, operation or maintenance of structures, accessories, equipment or materials not supplied by Graco.

This warranty is conditioned upon the prepaid return of the equipment claimed to be defective to an authorized Graco distributor for verification of the claimed defect. If the claimed defect is verified, Graco will repair or replace free of charge any defective parts. The equipment will be returned to the original purchaser transportation prepaid. If inspection of the equipment does not disclose any defect in material or workmanship, repairs will be made at a reasonable charge, which charges may include the costs of parts, labor, and transportation.

**THIS WARRANTY IS EXCLUSIVE, AND IS IN LIEU OF ANY OTHER WARRANTIES, EXPRESS OR IMPLIED, INCLUDING BUT NOT LIMITED TO WARRANTY OF MERCHANTABILITY OR WARRANTY OF FITNESS FOR A PARTICULAR PURPOSE.**

Graco's sole obligation and buyer's sole remedy for any breach of warranty shall be as set forth above. The buyer agrees that no other remedy (including, but not limited to, incidental or consequential damages for lost profits, lost sales, injury to person or property, or any other incidental or consequential loss) shall be available. Any action for breach of warranty must be brought within two (2) years of the date of sale.

**GRACO MAKES NO WARRANTY, AND DISCLAIMS ALL IMPLIED WARRANTIES OF MERCHANTABILITY AND FITNESS FOR A PARTICULAR PURPOSE, IN CONNECTION WITH ACCESSORIES, EQUIPMENT, MATERIALS OR COMPONENTS SOLD BUT NOT MANUFACTURED BY GRACO.** These items sold, but not manufactured by Graco (such as electric motors, switches, hose, etc.), are subject to the warranty, if any, of their manufacturer. Graco will provide purchaser with reasonable assistance in making any claim for breach of these warranties.

In no event will Graco be liable for indirect, incidental, special or consequential damages resulting from Graco supplying equipment hereunder, or the furnishing, performance, or use of any products or other goods sold hereto, whether due to a breach of contract, breach of warranty, the negligence of Graco, or otherwise.

## **FOR GRACO CANADA CUSTOMERS**

The Parties acknowledge that they have required that the present document, as well as all documents, notices and legal proceedings entered into, given or instituted pursuant hereto or relating directly or indirectly hereto, be drawn up in English. Les parties reconnaissent avoir convenu que la rédaction du présente document sera en Anglais, ainsi que tous documents, avis et procédures judiciaires exécutés, donnés ou intentés, à la suite de ou en rapport, directement ou indirectement, avec les procédures concernées.

## Graco Information

For the latest information about Graco products, visit [www.graco.com](http://www.graco.com).

**TO PLACE AN ORDER**, contact your Graco distributor or call 1-800-690-2894 to identify the nearest distributor.

*All written and visual data contained in this document reflects the latest product information available at the time of publication.  
Graco reserves the right to make changes at any time without notice.*

*For patent information, see [www.graco.com/patents](http://www.graco.com/patents).*

Original instructions. This manual contains English. MM 313890

**Graco Headquarters:** Minneapolis  
**International Offices:** Belgium, China, Japan, Korea

**GRACO INC. AND SUBSIDIARIES • P.O. BOX 1441 • MINNEAPOLIS MN 55440-1441 • USA**

**Copyright 2009, Graco Inc. All Graco manufacturing locations are registered to ISO 9001.**

[www.graco.com](http://www.graco.com)  
Revised June 2017